

SI-58/98 Infrared Touchless Sensor Operation & Installation Manual

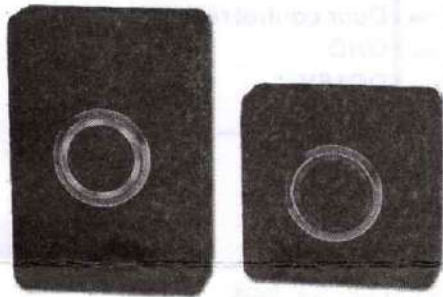

SI-58

SI-98

(Water proof version)

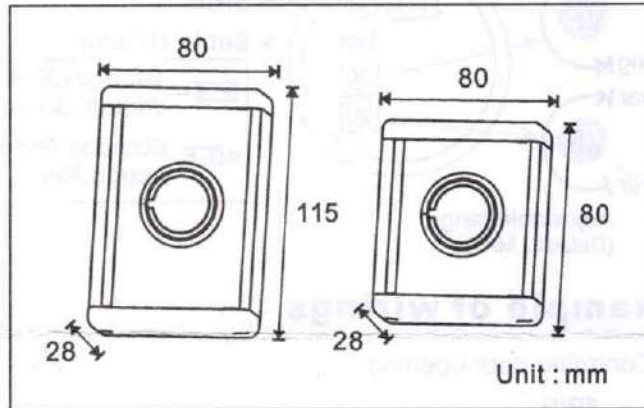

※ Please make sure no object (Include protection stickers) is blocking the infrared sensing panel before use.

I. Features :

- Activate without pressing to prevent any disease contagion. It is suitable for access control system that widely used in public areas such as hospitals or restaurants. It is also can be used as auto-control detection.
- Built-in microcontroller with power on self testing function.
- Specially designed to prevent any interference from other infra-red.
- Double color status light, adjustable proximity range.
- Door opening time is able to set trigger state (0.5~30sec) or toggle mode output
- Operating temperature : -10°C ~ +70°C.

II. Specification:

Power input	DC 5V
Range	4~15CM(±25%) ※ Note1
Output Loading	1A@DC30V(Max.)
Output State	Trigger state (0.5~30sec) or toggle mode output
Life Time	Infrared sensor:100,000 hours / Relay mechanical lifespan:1000,000 times
Indicator	Standby : RED ; Proximity : GREEN (Color of indicator light is adjustable)
Case	Stainless Steel / PC / Aluminum Alloy
Current Consumption	Maximum current 30mA@DC5V
Weight	SI-58 ; 270g/ SI-98 : 202g (G.W.)

※ Note1 : Different materials have different reflective rate. The value of the chart is based on the test of 18% neutral gray card.

III. Panel and Wirings :

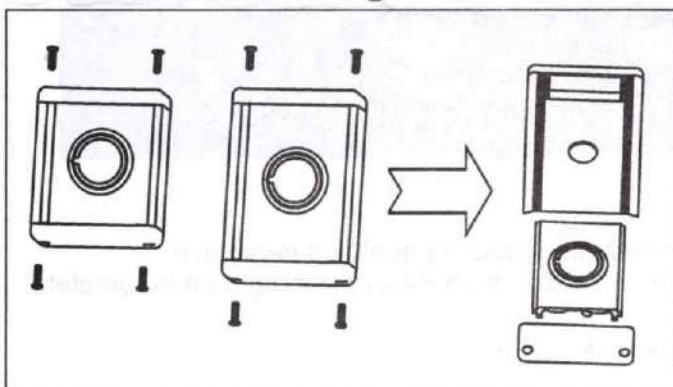

Front

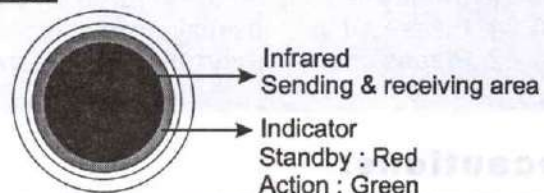

※ In order to ensure the operation of the infrared switch, please make sure no objects or any obstacles within 30cm (60° on the left and right) of the front panel of the switch to avoid any interference.

Back

(Can not adjustable ,sealed by resin for waterproof version)

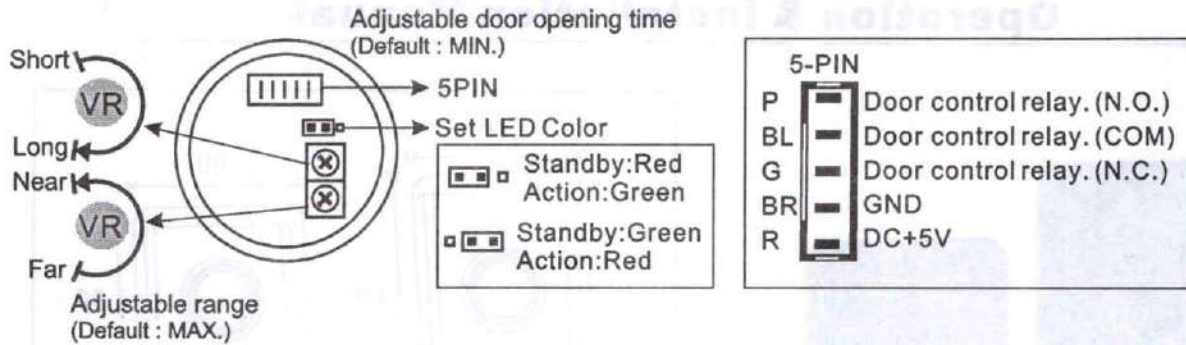

IV. Example of wirings :

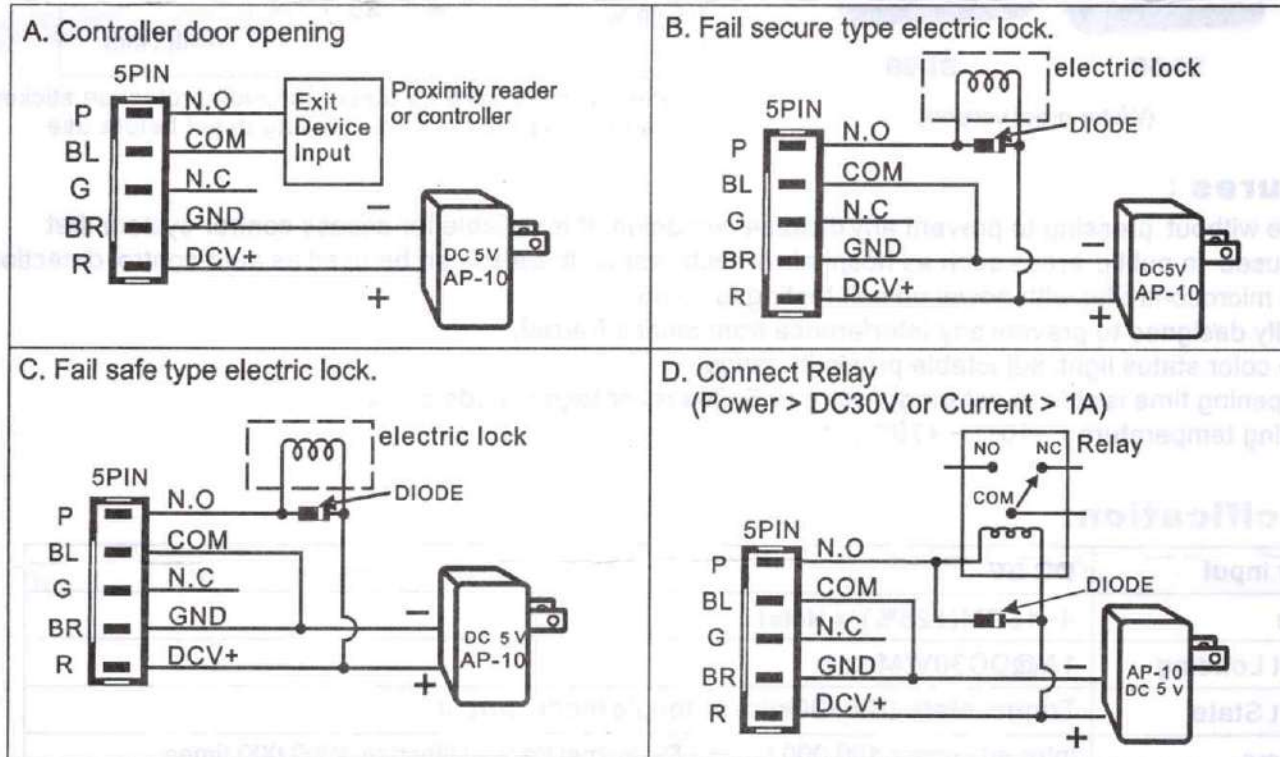

※ Please connect to diode when the control terminal is loading in order to absorb surge to prevent damage to the sensor.

Troubleshooting

Q : Always on action mode (indicator light does not change).

- A : 1. Please wipe the surface clean such as oil stain, liquid drops or marks and remove any objects in front of the proximity that may interfere its proximity range.
2. Please adjust the proximity distance. Shorter the distance may avoid interference.
3. Please check the voltage. Lower voltage may shorten the proximity distance or cause the switch unable to function.
4. Please check the delay setting time. If it is being set as too long or Toggle mode, it might affect its operation.

Q : Proximity failed even the infrared switch's power light is on.

- A : 1. Please adjust the proximity distance to check if it is too short.
2. Please check the current (5V). The switch is unable to function if the voltage is incorrect.

V. Precautions:

- Please do not conduct any fixing or modification to the system, unless by qualified personnel.
- Self testing function : Green light on for one second and no action from Relay → red light on to complete power on self testing).
- Warranty of the unit is one year under normal circumstances.