

ITEM NO.	PART NUMBER	DESCRIPTION	QTY.
1		POLYCARBONATE HOUSING	1
2		POLYCARBONATE RING	1
3		POLYCARBONATE DOOR	1
4		PIANO HINGE	1
6		6-32 SS PHILLIPS FLAT HEAD SCREWS	27

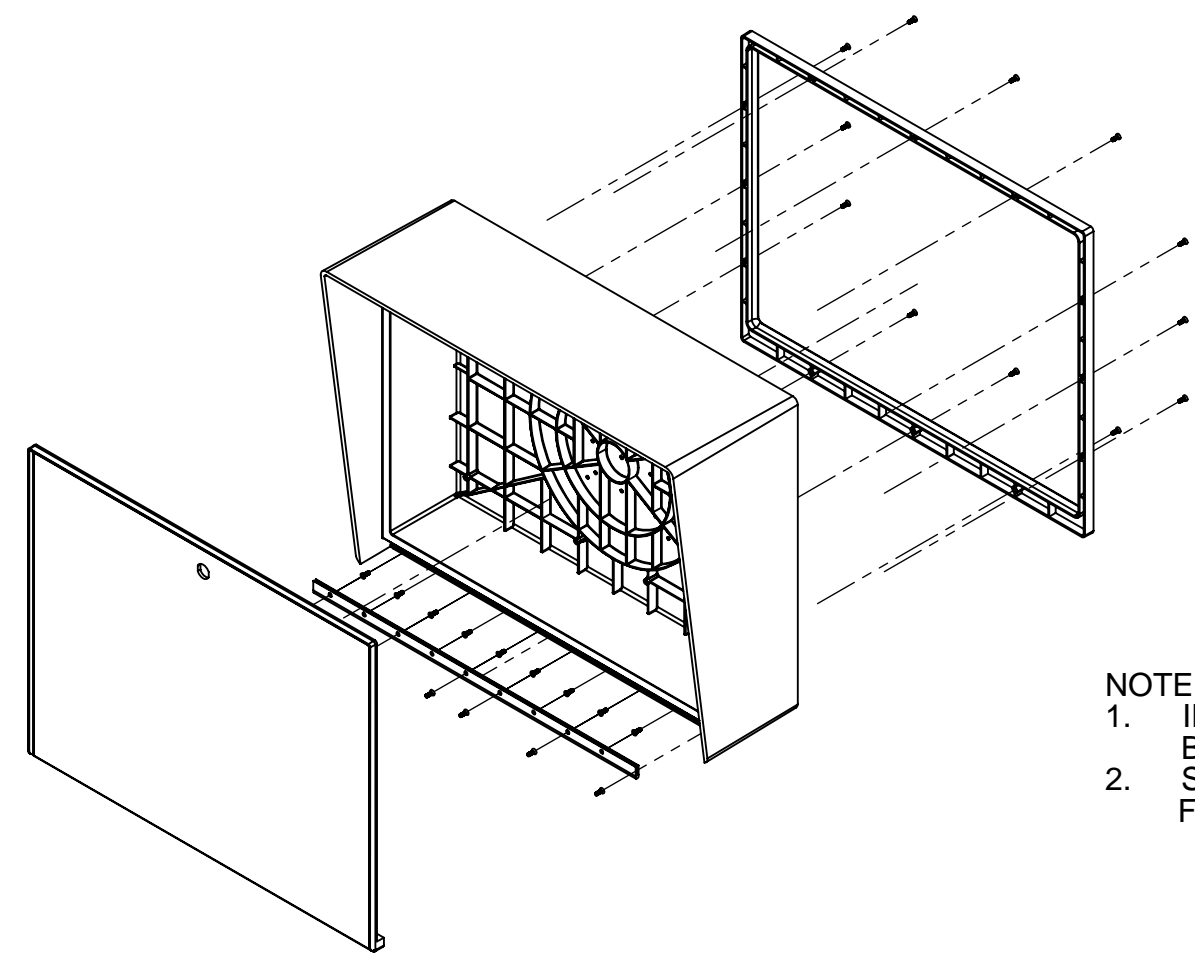

- NOTES:
1. INJECTION MOLDED ABS/POLYCARBONATE BLEND, BLACK COLOR, UV STABLE.
 2. SEE STANDARD PACKAGING INSTRUCTIONS FOR PACKAGING PROCEDURE.

	DIMENSIONS ARE IN INCHES TOLERANCES: FRACTIONAL 1/32 ANGULAR: 2 TWO PLACE DECIMAL 0.010 THREE PLACE DECIMAL 0.005 GENERIC TOLERANCING PER: ASME Y14.5 -2009	NAME	DATE	TITLE:	SIZE	PART NO.	REV
		DRAWN CHECKED			INSTALLATION	A	PD1081
				WEIGHT:		NO SCALE	

	UNLESS OTHERWISE SPECIFIED: DIMENSIONS ARE IN INCHES TOLERANCES: FRACTIONAL ±1/32 ANGULAR: ±2° TWO PLACE DECIMAL ± 0.010 THREE PLACE DECIMAL 0.005 GENERIC TOLERANCING PER: ASME Y14.5 -2009	NAME	DATE	TITLE:	SIZE	PART NO.	REV
		DRAWN CHECKED			ASSEMBLY	A	
				WEIGHT:		NO SCALE	