

2.00

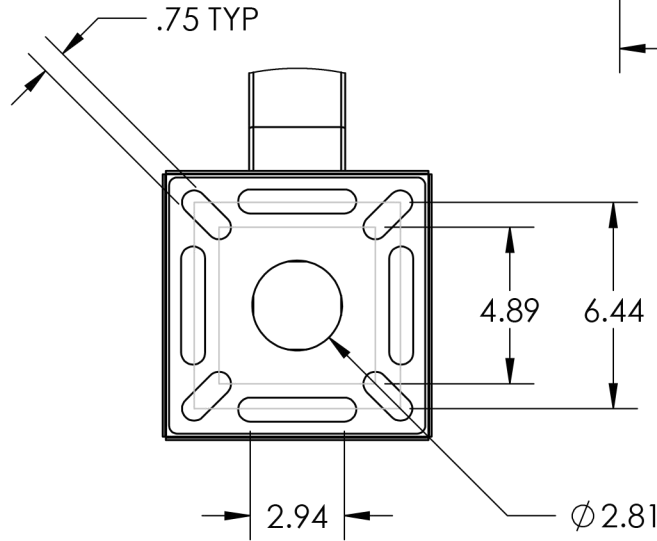

DETAIL A

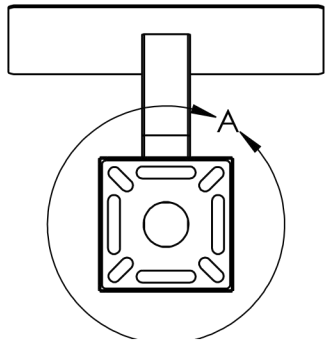
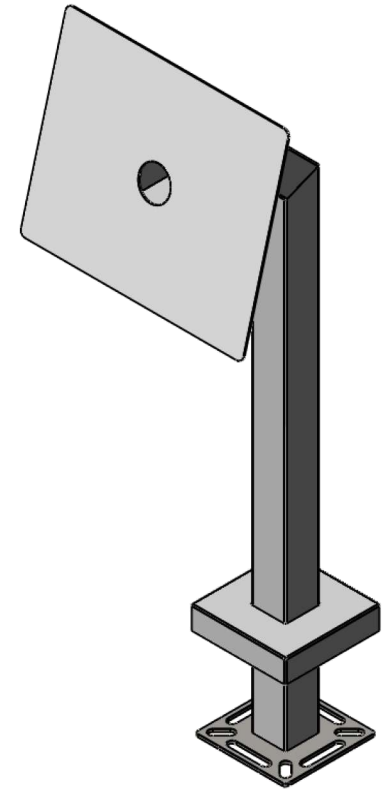
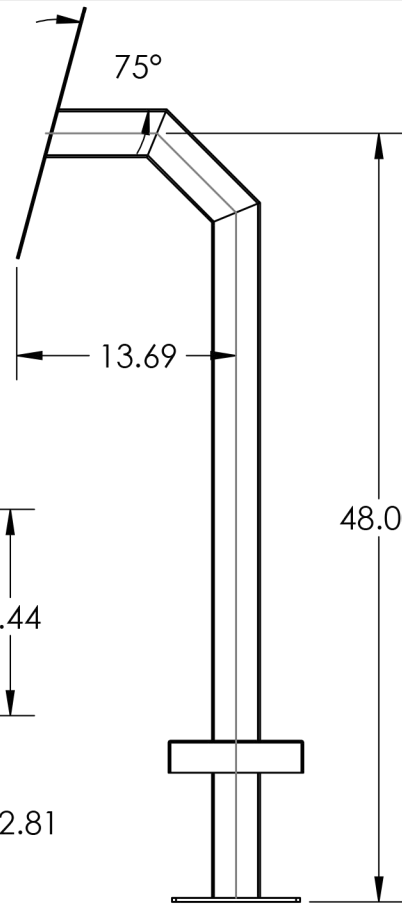

NOTES:
 1. MATERIAL OF CONSTRUCTION IS MILD STEEL
 COATED IN 2-4 MILS FLAT BLACK WITH ZINC
 ENRICHED PRIMER.



intercomsonline.com

UNLESS OTHERWISE SPECIFIED:

DIMENSIONS ARE IN INCHES
 TOLERANCES:
 FRACTIONAL $\pm 1/32$
 ANGULAR: $\pm 2^\circ$
 TWO PLACE DECIMAL ± 0.010
 THREE PLACE DECIMAL ± 0.005

INTERPRET GEOMETRIC
 TOLERANCING PER:
 ASME Y14.5 -2009

NAME DATE TITLE:

DRAWN		
CHECKED		

Part #: PD1080

ITEM NO.	PART NUMBER	DESCRIPTION	QTY.
1	33PE1-INVU-02-CRS	3 X 3 WELDMENT	1
2	PLTBAS-8-3	8" STANDARD BASE PLATE	1
3	PLTCOV-8-3	STANDARD COVER PLATE	1
4	33PE1-INVU-02-CRS FACE	CUSTOM INVICTUS FACE PLATE	1
5	--	1/4-20 X .5 ZINC PL CARRIAGE BOLT	4
6	--	1/4-20 ZINC PL HEX NUT	4

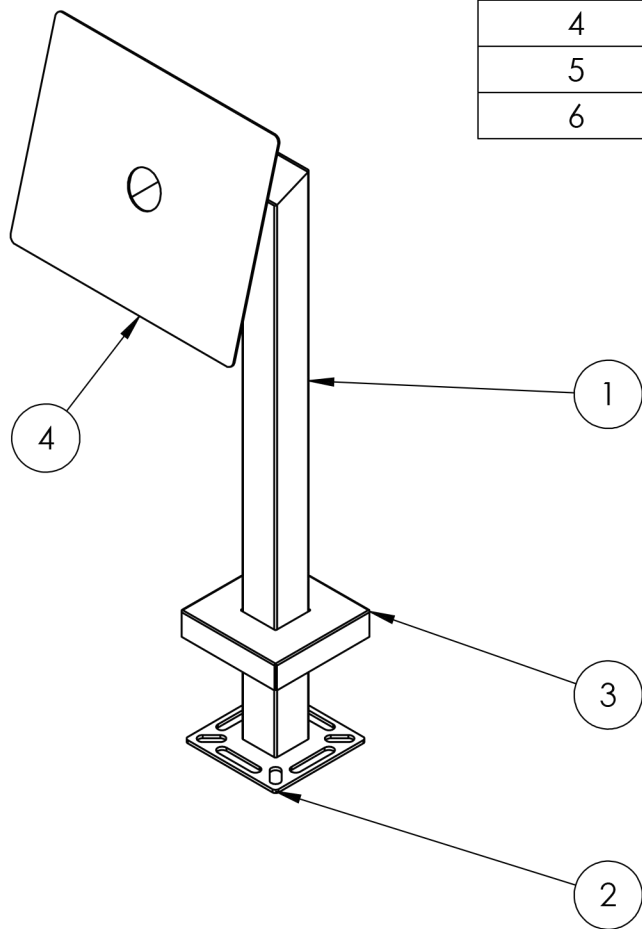

NOTES:

1. SEE STANDARD PREPARATION AND COATING INSTRUCTIONS FOR COATING PROCEDURE AND COLOR.
2. SEE STANDARD PACKAGING INSTRUCTIONS FOR PACKAGING PROCEDURE.

UNLESS OTHERWISE SPECIFIED:

DIMENSIONS ARE IN INCHES
TOLERANCES:
FRACTIONAL $\pm 1/32$
ANGULAR: $\pm 2^\circ$
TWO PLACE DECIMAL ± 0.010
THREE PLACE DECIMAL ± 0.005

INTERPRET GEOMETRIC
TOLERANCING PER:
ASME Y14.5 -2009

NAME DATE

TITLE:

DRAWN

Part #: PD1080