

SECTION A-A

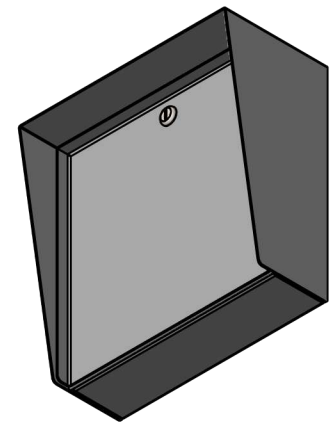
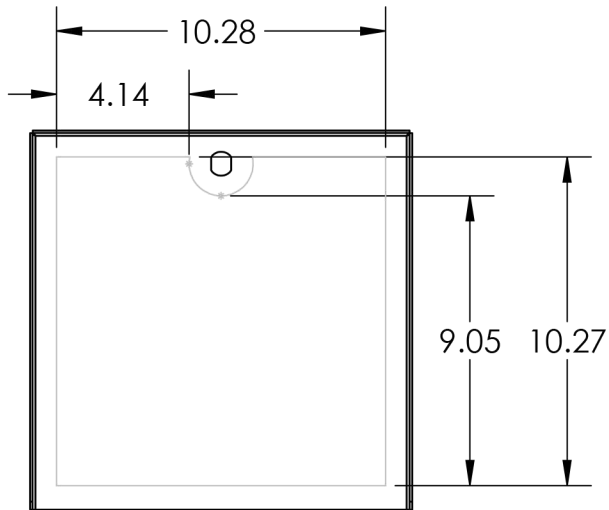
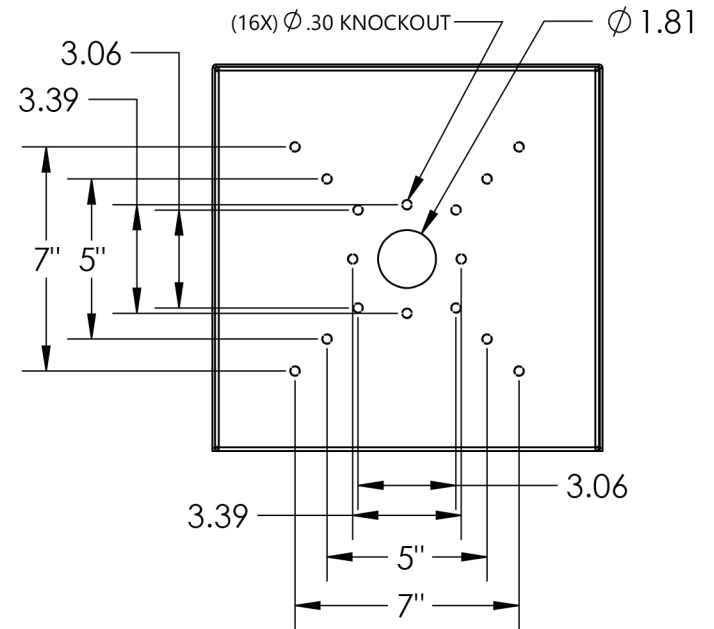

UNLESS OTHERWISE SPECIFIED:
 DIMENSIONS ARE IN INCHES
 TOLERANCES:
 FRACTIONAL $\pm 1/32$
 ANGULAR: $\pm 2^\circ$
 TWO PLACE DECIMAL ± 0.010
 THREE PLACE DECIMAL ± 0.005
 INTERPRET GEOMETRIC
 TOLERANCING PER:
 ASME Y14.5 -2009

	NAME	DATE
DRAWN		
CHECKED		

TITLE: INSTALLATION		
Tuesday, September 11, 2018 8:34:19 AM	SIZE A	PART NO. PD1079
WEIGHT:	NO SCALE	REV A
		SHEET 1 OF 6

ITEM NO.	PART NUMBER	DESCRIPTION	QTY.
1	MC-CS-12-E ENCLOSURE	14 GA MILD STEEL SHEET	1
2	MC-CS-12-E DOOR	DOOR WELDMENT	1
3	CAM LOCK	STRAIGHT CAM	1
4	GASKET SIDE	3/8 X .150 WEATHERSTRIPPING	2
5	GASKET TOP	3/8 X .150 WEATHERSTRIPPING	1
6	HINGE	PIANO HINGE	1
7	--	6-32 X 3/8 SS BUTTON HEAD SCREW	6
8	--	6-32 EXTERNAL TOOTH LOCK NUT	6

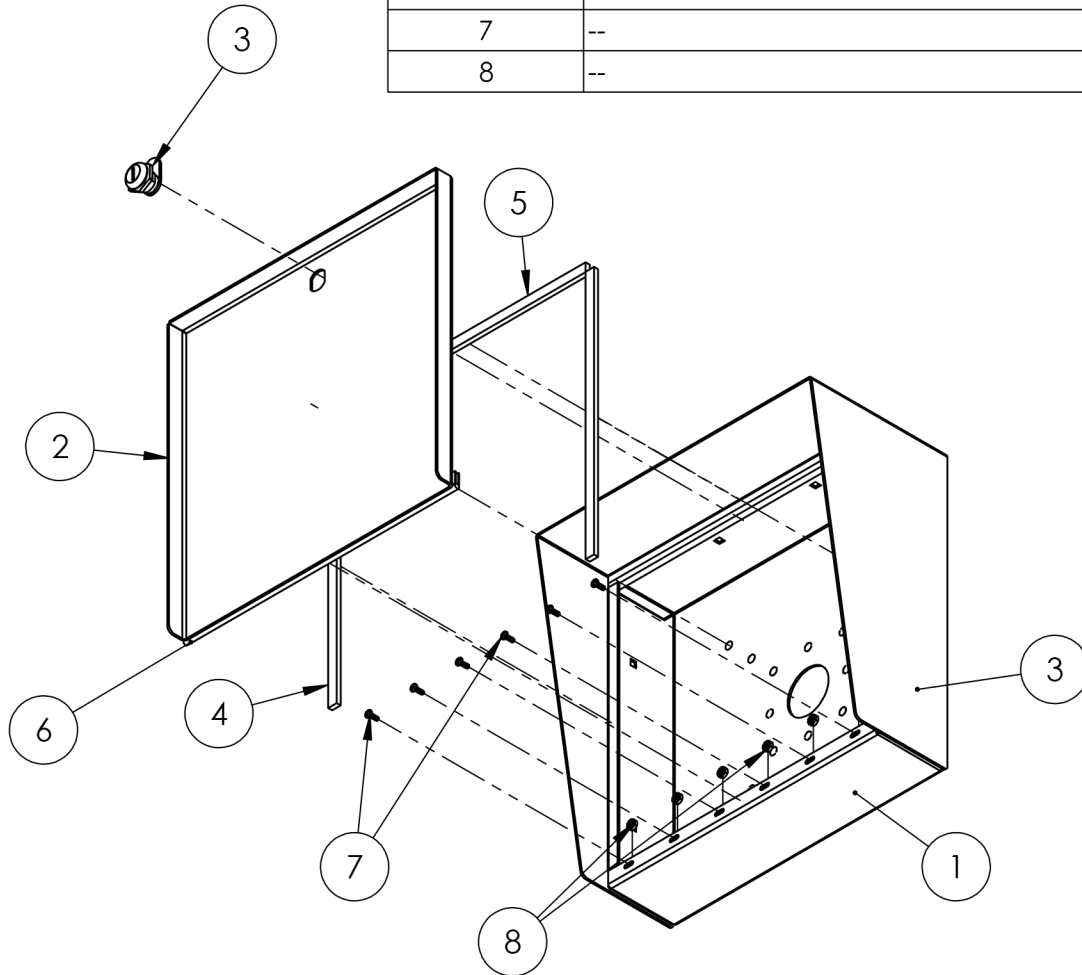

NOTES:

1. SEE STANDARD PREPARATION AND COATING INSTRUCTIONS FOR COATING PROCEDURE AND COLOR.
2. SEE STANDARD PACKAGING INSTRUCTIONS FOR PACKAGING PROCEDURE.

UNLESS OTHERWISE SPECIFIED:

DIMENSIONS ARE IN INCHES
TOLERANCES:
FRACTIONAL $\pm 1/32$
ANGULAR: $\pm 2^\circ$
TWO PLACE DECIMAL ± 0.010
THREE PLACE DECIMAL ± 0.005

INTERPRET GEOMETRIC TOLERANCING PER: ASME Y14.5 -2009

NAME DATE

DRAWN
CHECKED
PROPRIETARY AND CONFIDENTIAL
THE INFORMATION CONTAINED IN THIS DRAWING IS THE SOLE PROPERTY OF PEDESTALPRO LLC. ANY REPRODUCTION IN PART OR AS A WHOLE WITHOUT THE WRITTEN PERMISSION OF PEDESTALPRO LLC IS PROHIBITED.

TITLE:

ASSEMBLY

Tuesday, September 11, 2018 8:34:19 AM

WEIGHT:

SIZE
A

PART NO.

NO SCALE

REV
A

SHEET 2 OF 6