

NOTES:

1. 5/8" ϕ MOUNTING HARDWARE IS RECOMMENDED.
2. MOUNTS THE BUTTERFLY MX 7 INCH SURFACE MOUNT UNIT.



www.intercomsonline.com

UNLESS OTHERWISE SPECIFIED:

DIMENSIONS ARE IN INCHES
 TOLERANCES:
 FRACTIONAL $\pm 1/32$
 ANGULAR: $\pm 2^\circ$
 TWO PLACE DECIMAL ± 0.010
 THREE PLACE DECIMAL ± 0.005

INTERPRET GEOMETRIC
 TOLERANCING PER:
 ASME Y14.5 -2009

NAME DATE

DRAWN
 CHECKED

TITLE:

INSTALLATION

Part Number: PD1045

WEIGHT:

NO SCALE

SHEET 1 OF 6

ITEM NO.	PART NUMBER	DESCRIPTION	QTY.
1	33PED-BUT-002-304	3X3 304 SS TUBE	1
2	BACK PLATE 7S	7 INCH BMX BACK PLATE	1
3	FACE PLATE 7S	7 INCH BMX FACE PLATE	1
4	BASE PLATE 8 281	8" STANDARD BASE PLATE	1
5	COVER PLATE 8 3125	8" STANDARD COVER PLATE	1
6	KEYHOLE STUD	8MM KEYHOLE STUD	3

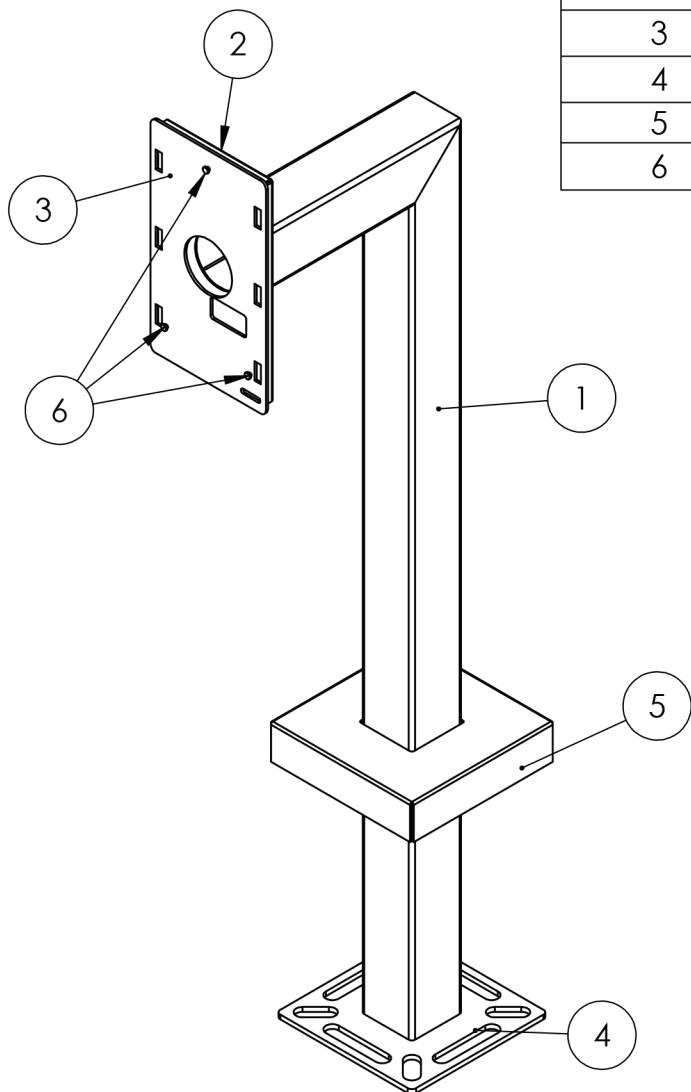

NOTES:

1. BUTT WELDED SECTIONS ARE NOT ALLOWED, EACH SECTION OF TUBE MUST BE FROM CONTINUOUS STOCK.
2. ALL WELDS ARE TO BE CONTINUOUS FILLET WELDS UNLESS NOTED OTHERWISE.
3. SEE STANDARD PREPARATION AND COATING INSTRUCTIONS FOR COATING PROCEDURE AND COLOR.
4. FASTENERS ARE TO BE BAGGED AND SHIPPED WITH PEDESTAL.
5. SEE STANDARD PACKAGING INSTRUCTIONS FOR PACKAGING PROCEDURE.



www.intercomsonline.com

UNLESS OTHERWISE SPECIFIED:

DIMENSIONS ARE IN INCHES
TOLERANCES:
FRACTIONAL: $\pm 1/32$
ANGULAR: $\pm 2^\circ$
TWO PLACE DECIMAL: ± 0.010
THREE PLACE DECIMAL: ± 0.005

INTERPRET GEOMETRIC
TOLERANCING PER:
ASME Y14.5 -2009

NAME

DATE

TITLE:

ASSEMBLY

DRAWN

CHECKED

WEIGHT:

NO SCALE

SHEET 2 OF 6