

NOTES:

1. 1/2"  $\phi$  MOUNTING HARDWARE IS RECOMMENDED FOR 5X5 BASEPLATE MODELS. L-BOLT-500, STUD-ANCHOR-500.
2. 5/8"  $\phi$  MOUNTING HARDWARE IS RECOMMENDED FOR 8X8 AND 12X12 BASEPLATE MODELS. L-BOLT-625, STUD-ANCHOR-625.



www.intercomsonline.com

UNLESS OTHERWISE SPECIFIED:

DIMENSIONS ARE IN INCHES  
 TOLERANCES:  
 FRACTIONAL  $\pm 1/32$   
 ANGULAR:  $\pm 2^\circ$   
 TWO PLACE DECIMAL  $\pm 0.010$   
 THREE PLACE DECIMAL  $\pm 0.005$

INTERPRET GEOMETRIC  
 TOLERANCING PER:  
 ASME Y14.5 -2009

NAME DATE

DRAWN  
 CHECKED

TITLE:

INSTALLATION

Thursday, October 25,  
 2018 2:57:46 PM

Part Number PD1005

WEIGHT:

NO SCALE

SHEET 1 OF 3

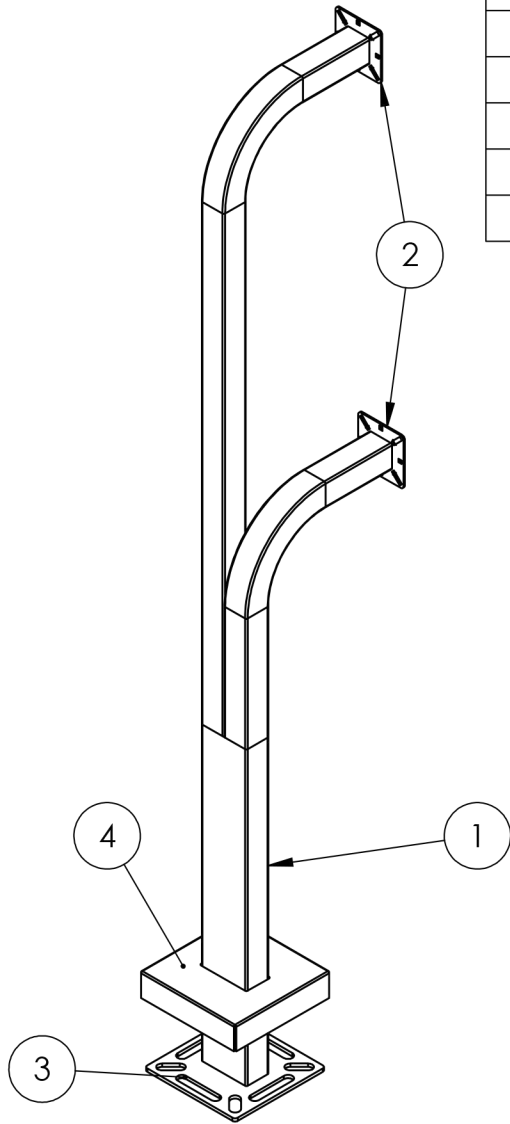

ITEM NO.	PART NUMBER	DESCRIPTION	QTY.
1	72-9C-D	2x2 STEEL TUBE	1
2	FACE PLATE 4	4" STANDARD FACE PLATE	2
3	BASEPLATE 8 181	8" STANDARD BASE PLATE	1
4	COVER PLATE 8 D24125	8" DUAL COVER PLATE	1
5	--	1/4-20 X .50 ZINC PL CARRIAGE BOLT	4
6	--	1/4-20 ZINC PL HEX NUT	4

NOTES:

1. BUTT WELDED SECTIONS ARE NOT ALLOWED, EACH SECTION OF TUBE MUST BE FROM CONTINUOUS STOCK.
2. ALL WELDS ARE TO BE CONTINUOUS FILLET WELDS UNLESS NOTED OTHERWISE.
3. SEE STANDARD PREPARATION AND COATING INSTRUCTIONS FOR COATING PROCEDURE AND COLOR.
4. FASTENERS ARE TO BE BAGGED AND SHIPPED WITH PEDESTAL.
5. SEE STANDARD PACKAGING INSTUCTIONS FOR PACKAGING PROCEDURE.

UNLESS OTHERWISE SPECIFIED:

DIMENSIONS ARE IN INCHES  
 TOLERANCES:  
 FRACTIONAL  $\pm 1/32$   
 ANGULAR:  $\pm 2^\circ$   
 TWO PLACE DECIMAL  $\pm 0.010$   
 THREE PLACE DECIMAL  $\pm 0.005$

INTERPRET GEOMETRIC  
 TOLERANCING PER:  
 ASME Y14.5 -2009

NAME DATE

DRAWN  
 CHECKED

TITLE:

ASSEMBLY

Thursday, October 25,  
 2018 2:57:46 PM

WEIGHT:

NO SCALE

SHEET 2 OF 3