

NOTES:  
 1/2"  $\phi$  MOUNTING HARDWARE IS RECOMMENDED FOR 5X5 BASEPLATE MODELS. L-BOLT-500, STUD-ANCHOR-500.  
 5/8"  $\phi$  MOUNTING HARDWARE IS RECOMMENDED FOR 8X8 AND 12X12 BASEPLATE MODELS. L-BOLT-625, STUD-ANCHOR-625



www.intercomsonline.com

|         | NAME | DATE |
|---------|------|------|
| DRAWN   |      |      |
| CHECKED |      |      |

TITLE:  
**INSTALLATION**

Thursday, October 25,  
 2018 2:57:46 PM

WEIGHT:

Part Number: PD1003

NO SCALE

SHEET 1 OF 3

| ITEM NO. | PART NUMBER   | DESCRIPTION                        | QTY. |
|----------|---------------|------------------------------------|------|
| 1        | 42-TT         | 2x2 STEEL TUBE                     | 1    |
| 2        | BASE PLATE 5  | 5" STANDARD BASE PLATE             | 1    |
| 3        | COVER PLATE 5 | 5" STANDARD COVER PLATE            | 1    |
| 4        | FACE PLATE 4  | 4" STANDARD FACE PLATE             | 2    |
| 5        | --            | 1/4-20 X .50 ZINC PL CARRIAGE BOLT | 4    |
| 6        | --            | 1/4-20 ZINC PL HEX NUT             | 4    |

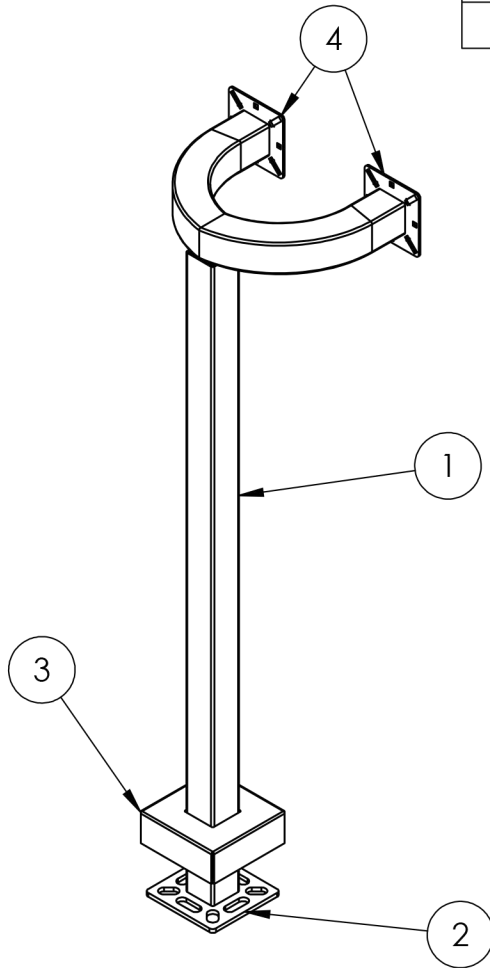

NOTES:

1. BUTT WELDED SECTIONS ARE NOT ALLOWED, EACH SECTION OF TUBE MUST BE FROM CONTINUOUS STOCK.
2. ALL WELDS ARE TO BE CONTINUOUS FILLET WELDS UNLESS NOTED OTHERWISE.
3. SEE STANDARD PREPARATION AND COATING INSTRUCTIONS FOR COATING PROCEDURE AND COLOR.
4. FASTENERS ARE TO BE BAGGED AND SHIPPED WITH PEDESTAL.
5. SEE STANDARD PACKAGING INSTRUCTIONS FOR PACKAGING PROCEDURE.

|  |  |         |      |  |                       |
|--|--|---------|------|--|-----------------------|
|  |  |         |      | TITLE:                                   |                       |
|  |  | NAME    | DATE | <b>ASSEMBLY</b>                          |                       |
|  |  | DRAWN   |      |  |                       |
|  |  | CHECKED |      | Thursday, October 25,<br>2018 2:57:46 PM |                       |
|  |  |         |      | WEIGHT:                                  | NO SCALE SHEET 2 OF 3 |