

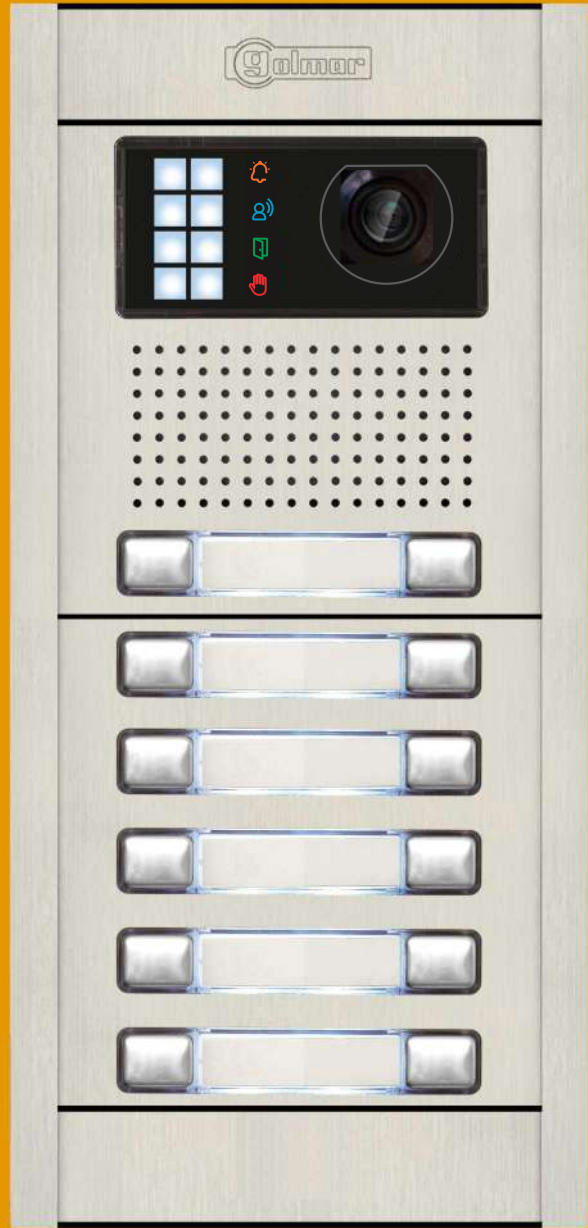

USER MANUAL



Audio and Video Door Entry System G2+ Nexa Modular 2-Wire



INTRODUCTION

First and foremost we would like to thank you for purchasing this product. Our commitment to achieving the satisfaction of customers like you is manifested through the manufacturing of products like the one you have just purchased. Its advanced technology and strict quality control will ensure that customers and users enjoy the numerous features that this device offers. To get the most out of them and ensure proper operation from day one, we recommend that you read this instruction manual.

CONTENTS

Introduction.....	2
Contents.....	2
Set-up warnings.....	2
Safety precautions.....	3
Characteristics.....	3
System operation.....	3
Description of the Nexa Modular door panel.....	
Description of the door panel.....	4
Description of the EL632 G2+ SE / EL642 G2+ sound module.....	5
Description of the EL610D button modules.....	6
Positioning the embedding box.....	7
Preparing the cable entry.....	7
Fitting the embedding box.....	8
Mounting the electronic modules.....	8
Fastening the frame to the embedding box.....	9
Connecting the buttons to the short connection cable.....	9
Connecting the buttons to the RAP-610D short connection cable.....	10
Configuring the button code (video installation up to 32 monitors/ apartments).....	10
Configuring double button module codes.....	11
Configuring single button module codes.....	12-13
Configuring the button code (only audio installation up to 128 terminals apartments).....	14-15
Configuring double button module codes.....	16-19
Configuring single button module codes.....	20-23
Description of the DIP switch.....	24
Audio level jumper description (vocal synthesis and tones mode).....	24
Description of the LED lights (low light conditions).....	24
Description of the visual signals on the door panel.....	25
Description of the vocal synthesis (audible signals on the door panel).....	25
Description of the tones mode audible signals on the door panel.....	25
Description of the P1 and P2 external call buttons (video module).....	25
Description connector to digital converter CD-NEXA/G2+ / connection illumination EL3002 module.....	26
Selecting vocal synthesis language or tones mode.....	27
To change the call code P1 and P2 push button (sound module) / final adjustments.....	28
Closing the frame and Inserting the button identification labels.....	29
Mounting the door panel/double door panel modules and closing the door panel.....	30-32
Installing the lock release installation.....	32
Installing the power supply unit (FA-G2+).....	33
Wiring diagrams.....	34-52
Installation riser types.....	53-57
Connection of an external camera.....	58
Cleaning the door panel.....	58
Notes.....	59
Compliance.....	60

SET-UP WARNINGS

- Do not overtighten the screws on the power supply connector.
- **Always disconnect the power supply** before installing or making modifications to the devices.
- The fitting and handling of these devices must be carried out by **authorised personnel**.
- The wiring must run at least **40cm (15.75") away from any other wiring**.
- Before connecting the device to the mains, check the connections between the door panel, power supply unit, distributors monitors and audio terminals.
- Use a pair of AWG #18 wires (2x1mm²).
- Always follow the instructions contained in this manual.



















SAFETY PRECAUTIONS

- **Always disconnect the power supply** before installing or making modifications to the devices.
- The fitting and handling of these devices must be carried out by **authorised personnel**.
- The wiring must run at least **40 cm away from any other wiring, (or 15.75")**.
- On the power supply unit:
 - ⚠ Do not over-tighten the screws on the connector.
 - ⚠ Install the power supply unit in a dry and protected place free from the risk of water leaks or sprays.
 - ⚠ Avoid locations that are humid, dusty or near heat sources.
 - ⚠ Ensure that the air vents are free from obstruction so that air can circulate freely.
 - ⚠ To avoid damage, the power supply unit must be firmly secured in place.
 - ⚠ To prevent electric shock, do not remove the cover or handle the wiring connected to the terminals.

CHARACTERISTICS

- Audio and video door entry system with simplified wiring (non-polarised 2-wire bus).
- Up to 4 access panel (DPM-G2 multiplexer required for more than one access panel) per installation.
- Up to 32 monitors and apartments with a ART 4 / ART 4 LITE monitor per installation.
- Up to 32 monitors and apartments with a ART 7 / ART 7 LITE monitor per installation.
- Up to 32 monitors and apartments with a ART 7W/G2+ monitor per installation.
- Up to 32 monitors/ART1 audio terminals and apartments in mixed installations (terminals and monitors).
- Up to 128 ART1 audio terminals and apartments per installation.
- Up to 4 monitors per apartment.
- Up to 8 monitors in parallel (in 1 output (to monitor) of the distributor), see pages 48 and 56-57.
- Up to 12 monitors in parallel (installation without distributors) per installation.
- Video module EL632G2SE with pan and tilt mechanism to adjust the camera position.
- Call confirmation tone.
- Visual signals on the door panel for people with impaired hearing (indicating call process, communication, door open and channel busy).
- Audible signals on the door panel for people with impaired vision (indicating call in progress, resident unavailable, door open and call finished).
- Door opening timeable from monitor (up to 10 seconds), see corresponding monitor user manual.
- 2 outputs for independently activated lock releases.
- Relay 1 and relay 2 output to activate the DC or AC lock releases actuated by relay.
- Input for external door opening button (Relay 1 output).
- Input for external door opening button (Relay 2 output).
- Maximum distance between the power supply & the first distributor (video door panel): ~262' with a cross-section of 1mm.²
- Maximum distance between first distributor & last distributor:(video door panel) ~262' with a cross-section of 1mm.²
- Maximum distance between distributor & monitor (video door panel): ~98' with a cross-section of 1mm.²
- Maximum distance between power supply and door panel (video door panel): ~262' with a cross-section of 1mm.²
- Maximum distance between power supply and last monitor "with distributors": ~623' with a cross-section of 1mm.²
- Maximum distance between power supply and last monitor (without distributors): see pages 45, 48 & 56-57.

SYSTEM OPERATION

- To make a call, the visitor must press the button of the apartment; an audible sound indicates that the call is being made and LED  will turn on. If vocal synthesis is enabled, a 'Call is in progress' message appears indicating that a call is being made. At this moment, the apartment's monitors receive the call. If another apartment is called by mistake, press the button for the correct apartment and the first call will be cancelled.
- Upon receiving the call, the image will appear on the screen of the master monitor (and slave 1, if it exists) without the visitor knowing and icon  displayed on the screen will blink green. To view the image from slave monitors 2 or 3, press on one of the buttons of the ART 4/ ART 7 monitor or press the screen of the ART 7W monitor for the image to appear. If the call is not answered within 45 seconds, LED  will turn off and the system will become free.
- To establish communication, press the button below off-the-hook icon  of the ART 4 / ART 7 monitor, press off-the-hook icon  on the screen of the ART 7W monitor or press the button  of the ART1 terminal. Door panel LED  will turn off and the led  will turn on. If the door panel has an EL3002H module with icon  displayed on the front, the LED of the EL3002H module will illuminate. Make sure that the hearing aid is 0.5" - 0.75" away from the door panel to ensure maximum audio quality during communication with the apartment.
- Connection will last for 90 seconds or until is pressed the button below on-the-hook icon  of the ART 4/ ART 7 monitor, is pressed on-the-hook icon  on the screen of the ART 7W monitor or is pressed the button  of the ART1 terminal. When communication ends, LED  will turn off and the system will become free. If vocal synthesis is enabled, a 'Communication is finished' message will indicate that the call is over.
- To open door  or  of the door panel, press the corresponding button below of the ART 4 /ART 7 monitor, press the corresponding icon on the screen of the ART 7W monitor or press the corresponding button  door 1 or  door 2, during the call or communication processes: one press will activate the lock release for 3 seconds and LED  will also turn on for 3 seconds. If vocal synthesis is enabled, a 'Door is open' message will be indicated on the door panel.
- Detailed operation and configuration of the monitor, see the corresponding monitor user manual.

DESCRIPTION OF THE NEXA MODULAR DOOR PANEL

Description of the door panel:

Door panel component assembly drawing.

Embedding boxes

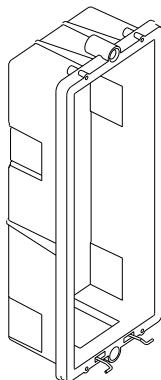

Frame modules

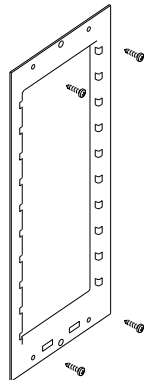

Electronic modules

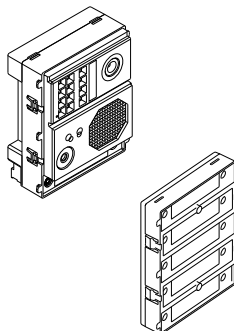

Aluminium panel

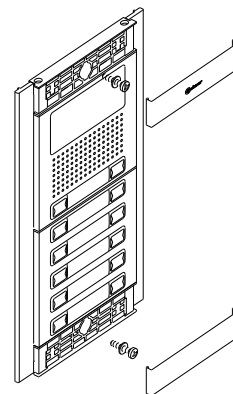

Description of the door panel.

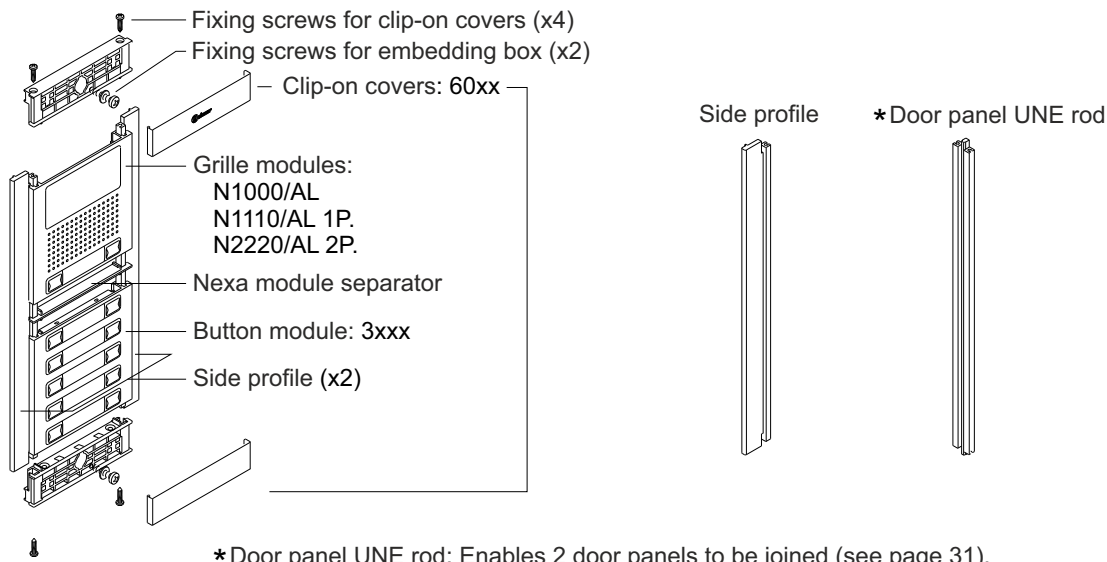

Video module
EL632/G2SE , in video door entry systems with colour television camera.

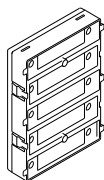

Button module
EL610D, for 5 individual or 10 double buttons.



Short connection cable supplied with the EL610D module (length 16 cm).
For connecting the buttons between the sound module and the EL610D button module and between EL610D button modules.

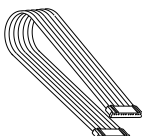

RAP-610D connection cable (length 27 cm).
For connecting the buttons between the sound module and the EL610D button module and between EL610D button modules.
This hose is required when the distance between modules to be connected is greater due to their distribution in the door panels.

DESCRIPTION OF THE EL632G2 P/T SOUND MODULE

Description of the EL632G2SE

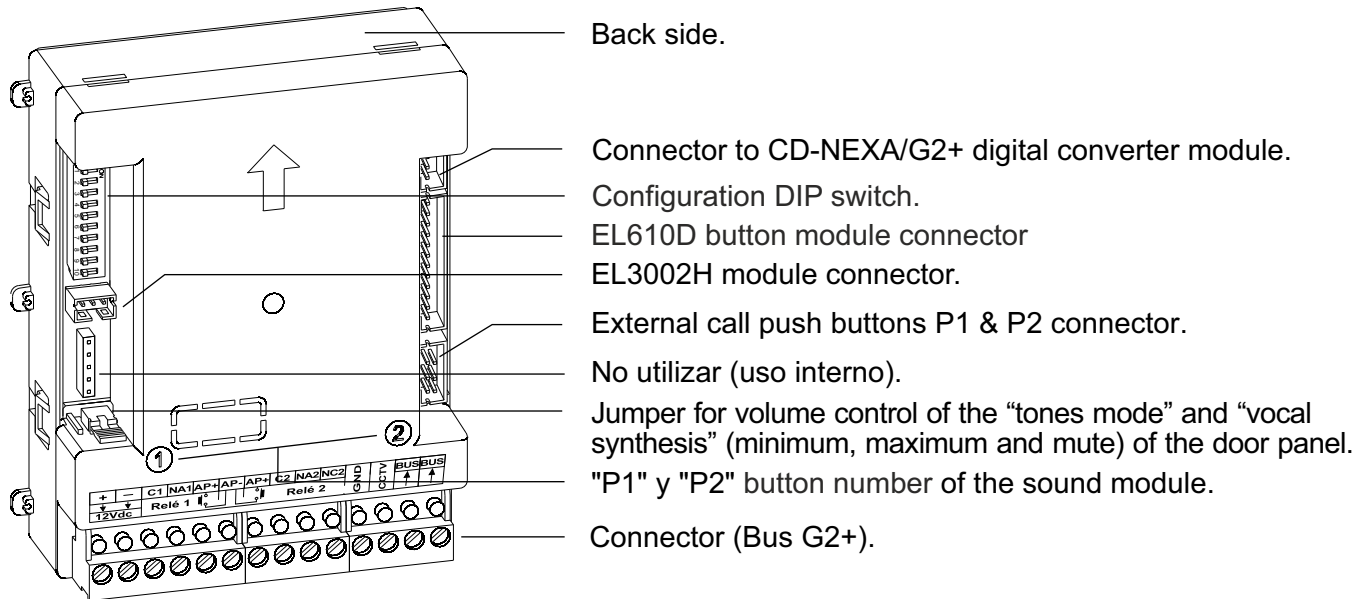
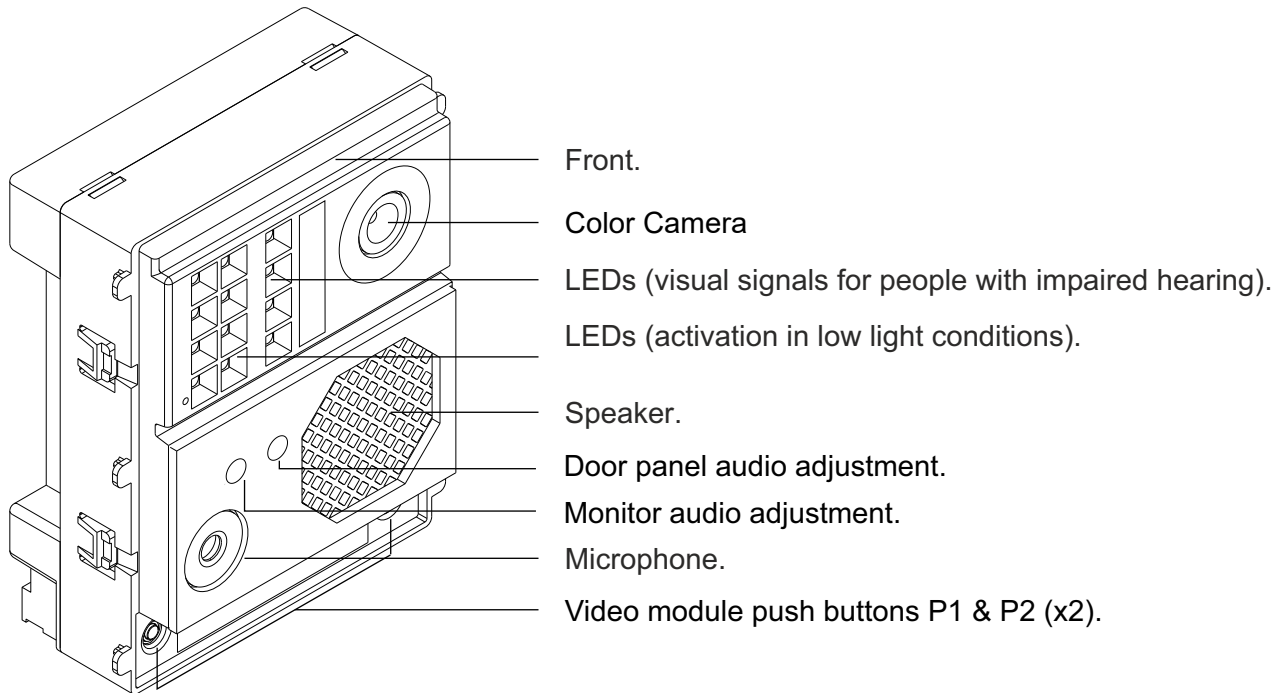

Connection terminals:

- + , - : Positive, negative (DO NOT USE FOR DOOR RELEASE).
- C1 : Contact "C" for electric lock (Relay 1).
- NA1 : Contact "NO" for electric lock (Relay 1).
- AP+ : Input for external door opening button (Relay 1).
- AP- : Input for external doors opening buttons (Relay 1 and Relay 2).
- AP+ : Input for external door opening button (Relay 2).
- C2 : Contact "C" for electric lock (Relay 2).
- NA2 : Contac "N.O" for electric lock (Relay 2).
- NC2 : Contac "N.C" for electric lock (Relay 2)
- GND : Input GND for CCTV analogic camera.
- CCTV : Input for CCTV analogic camera.
- BUS : Connection BUS (non-polarised).
- BUS : Connection BUS (non-polarised).

Note: See wiring diagrams for connections (pages 23 to 34).

DESCRIPTION OF THE EL610D BUTTON MODULE

Description of the EL610D button module:

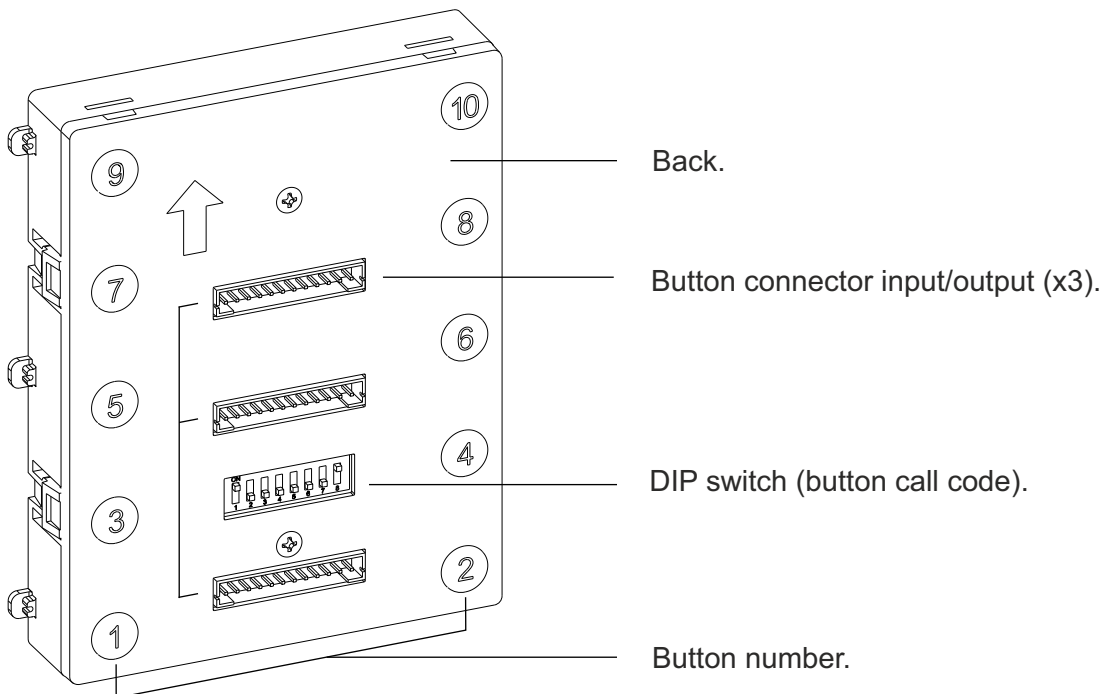
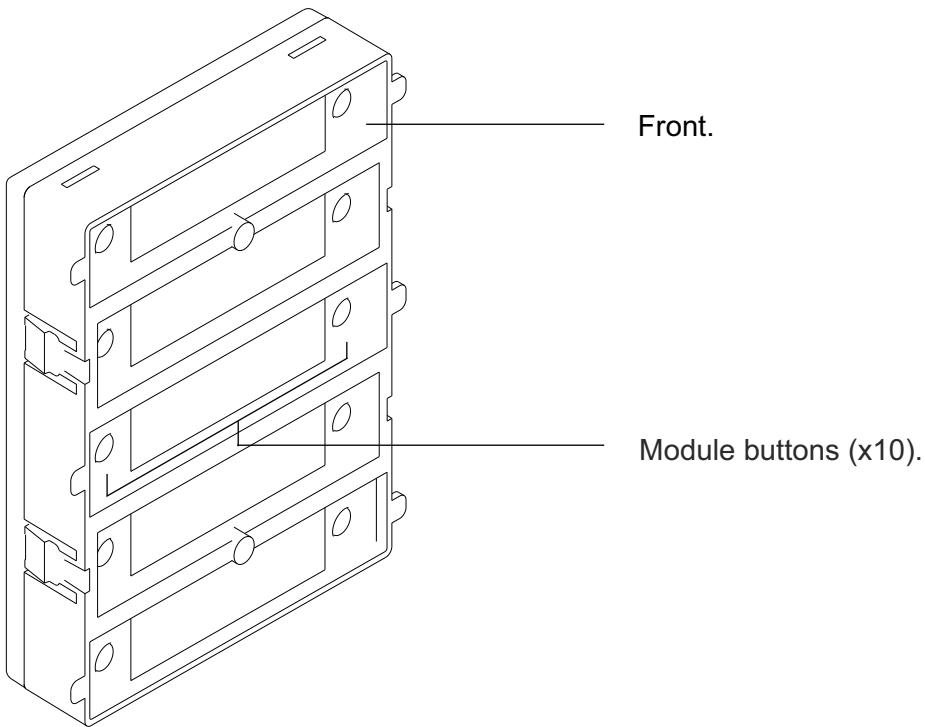

INSTALLATION OF THE DOOR PANEL

Positioning the embedding box:

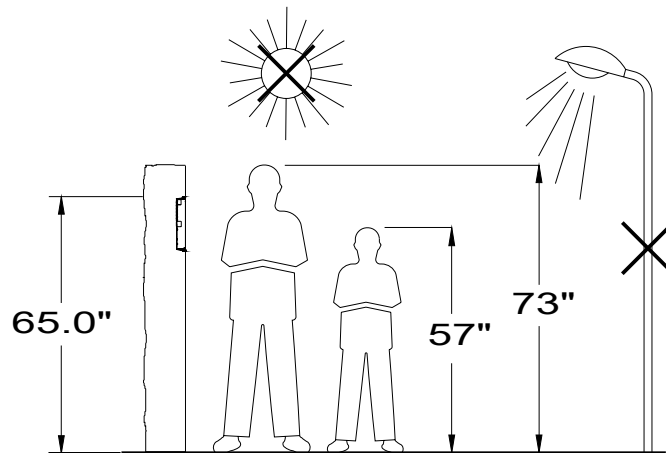

Make a hole in the wall to position the top of the door panel at a height of 65.0".
Hole dimensions depend on the type of door panel.

Modules Model	1 NCEV90CS	2 NCEV90C	3 CEV90
W (width)	3.9"	3.9"	3.9"
H (height)	5.2"	9.4"	12.9"
D (depth)	2.25"	2.2"	2.2"

The door panel has been designed to be used under most environmental conditions. It is however advisable to take extra precautions to prolong its service life (shields, covered areas, etc.). To obtain optimum video door entry system image quality, avoid direct contact from light sources (sunshine, street lights, etc.)

Preparing the cable entry:

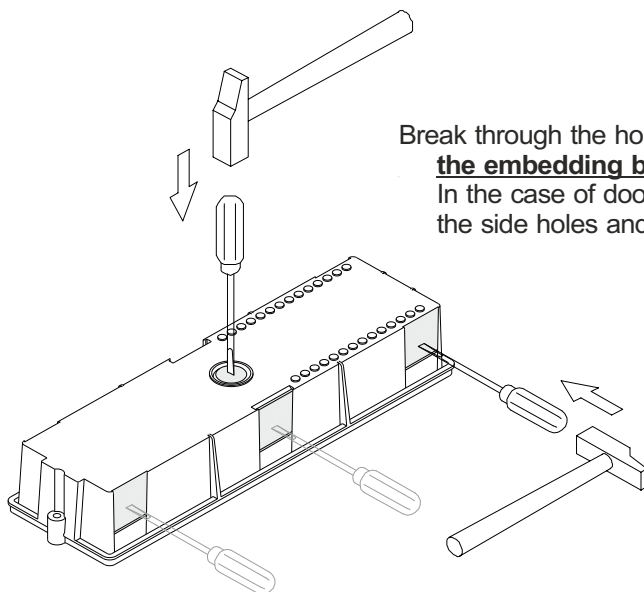

Break through the hole to allow **entry of cables through the bottom part of the embedding box.**

In the case of door panels with more than one embedding box, break through the side holes and join the embedding boxes using cable grommets.

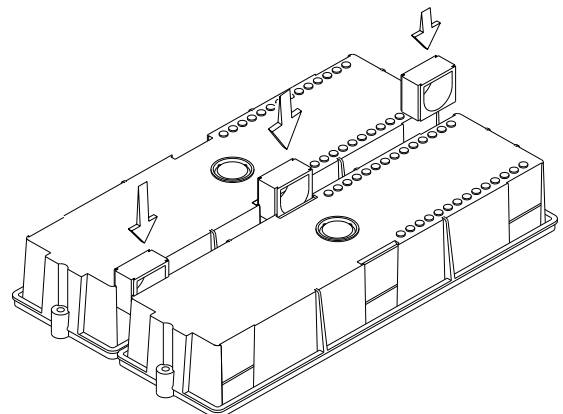

INSTALLATION OF THE DOOR PANEL

Fitting the embedding box:

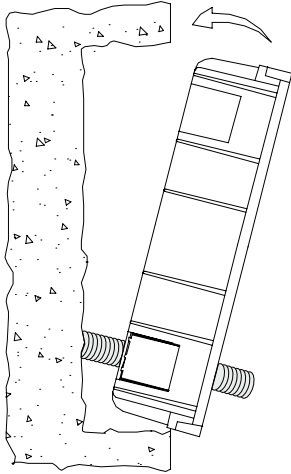

Pass the cable through the hole made in the embedding box. Embed the box and ensure that it is level and flush. Once the embedding box is positioned, remove the protective stickers from the door panel's fixing holes.

Mounting the electronic modules:

Insert the sound module into the top of the frame module.

Line up the clips on the sound module with the respective housings on the frame module and then press gently until correctly positioned.

If there is a button module, repeat the above process, positioning it below the sound module, as shown in the drawing.

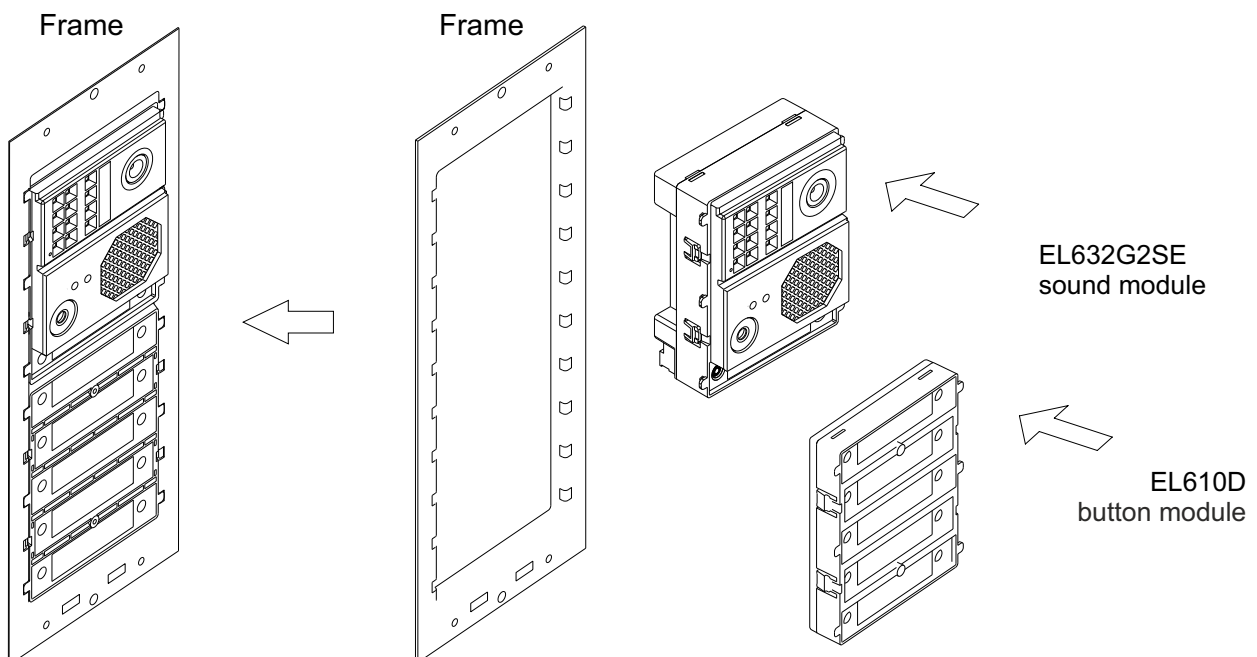

INSTALLATION OF THE DOOR PANEL

Fastening the frame to the embedding box:

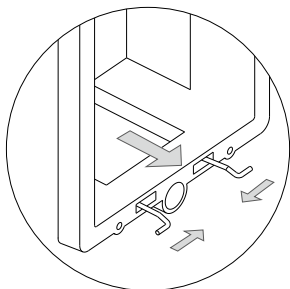

Insert the spring hinge which attaches to the product in the embedding box, as shown in the drawing.

To fasten the frame to the embedding box, insert the spring hinge into the housings provided for this purpose in the frame, as shown in the drawing.

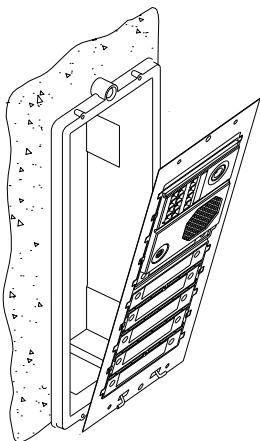
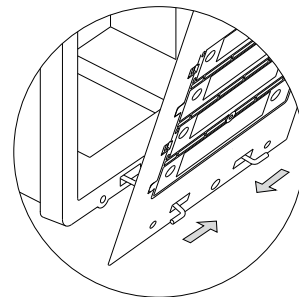

The frame can now be tilted horizontally to enable sound module and button module connection and setting.

Connecting the buttons to the short connection cable:

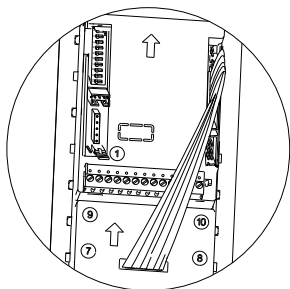

Insert one end of the short connection cable supplied with the EL610D product into the sound module connector and the other end into the connector situated at the top of the EL610D button module, as shown in the drawing.

Between EL610D button modules in the same embedding box, insert the short connection cable from the lower connector of the first button module into the upper connector of the second button module, as shown in the drawing.

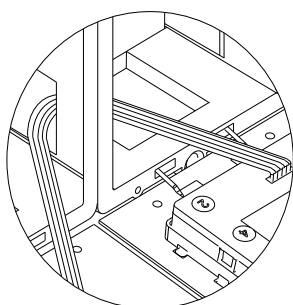
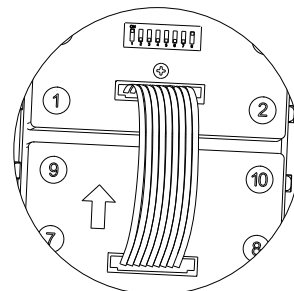

Between EL610D button modules in different embedding boxes, insert one end of the short connection cable into the lower connector of the final EL610D module in the first embedding box and the other end into the middle connector of the last EL610D button module situated at the bottom of the second embedding box, as shown in the drawing.

INSTALLATION OF THE DOOR PANEL

Connecting the buttons to the RAP-610D short connection cable:

Use the RAP-610D connection cable to connect the buttons between the sound module and the EL610D button module and between EL610D button modules when the distance between modules to be connected is greater due to the composition of the door panels.

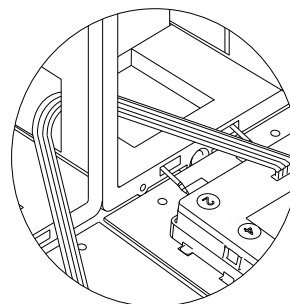

Configuring the button code (video installation up to 32 monitors/ apartments):

The EL610D button module needs to be configured in order to assign a call code to the buttons. Carry out this configuration with the DIP switch located at the back of the module.

Depending on the configuration option selected, the buttons will be assigned with a certain call code.

To configure the call code on the monitors. It is worth noting the call code of each button, as shown in the table below.

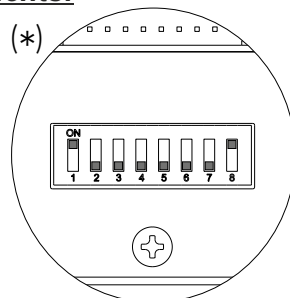

IMPORTANT: Mixed installation with monitors and audio terminals up to 32 elements/apartments.

EL610D button module **Double button module codes**

		DIP switch							Button code											
		Dip1	Dip2	Dip3	Dip4	Dip5	Dip6	Dip7	Dip8	P1	P2	P3	P4	P5	P6	P7	P8	P9	P10	(1)
Module configuration option	1	On	Off	Off	Off	Off	Off	Off	On	1	2	3	4	5	6	7	8	9	10	(*)
	2	Off	On	Off	Off	Off	Off	Off	On	11	12	13	14	15	16	17	18	19	20	
	3	Off	Off	On	Off	Off	Off	Off	On	21	22	23	24	25	26	27	28	29	30	

Single button module codes

		Dip1	Dip2	Dip3	Dip4	Dip5	Dip6	Dip7	Dip8	P1	P3	P5	P7	P9	(1)
Module configuration option	1	On	Off	Off	Off	Off	Off	Off	On	1	2	3	4	5	(*)
	2	Off	On	Off	Off	Off	Off	Off	On	6	7	8	9	10	
	3	Off	Off	On	Off	Off	Off	Off	On	11	12	13	14	15	
	4	Off	Off	Off	On	Off	Off	Off	On	16	17	18	19	20	
	5	Off	Off	Off	Off	On	Off	Off	On	21	22	23	24	25	
	6	Off	Off	Off	Off	Off	On	Off	On	26	27	28	29	30	
	7	Off	Off	Off	Off	Off	Off	On	On	31	-	-	-	-	

(1) P1- P10: Button 1 - button 10

Nota: EL632G2SE module , factory default with the code "32" in P1 and "31" in P2.

Important: Select a different configuration option for each EL610D module.

(*) **Factory default.**

NEXA MODULAR G2+ AUDIO AND VIDEO DOOR ENTRY SYSTEM - BUILDING 11

INSTALLATION OF THE DOOR PANEL

Configuring double button module codes:

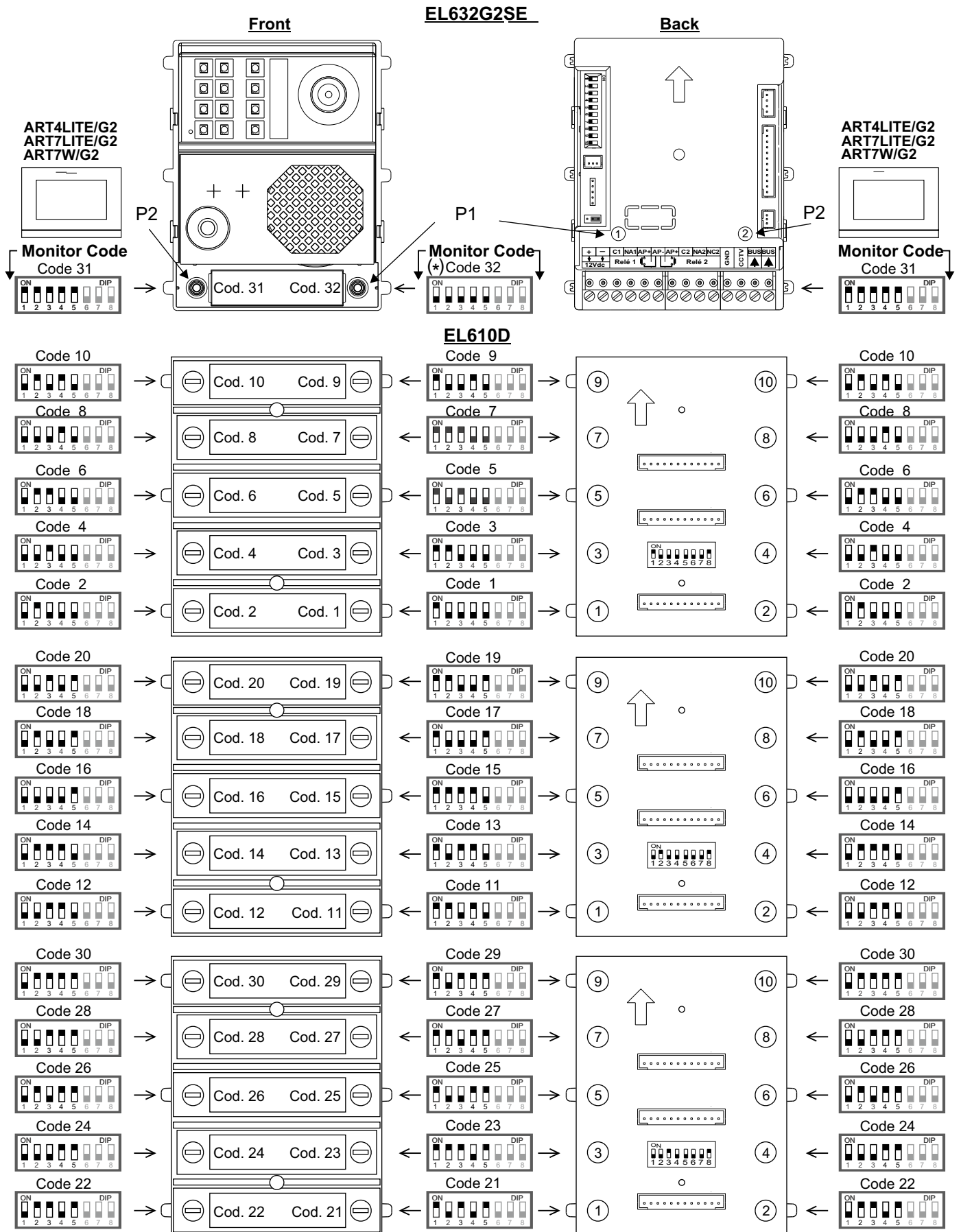

(*) Mixed installations with monitors/ terminales, the "code 32" in ART1 terminal is:



NEXA MODULAR G2+ AUDIO AND VIDEO DOOR ENTRY SYSTEM - BUILDING 12

INSTALLATION OF THE DOOR PANEL

Configuring single button module codes:

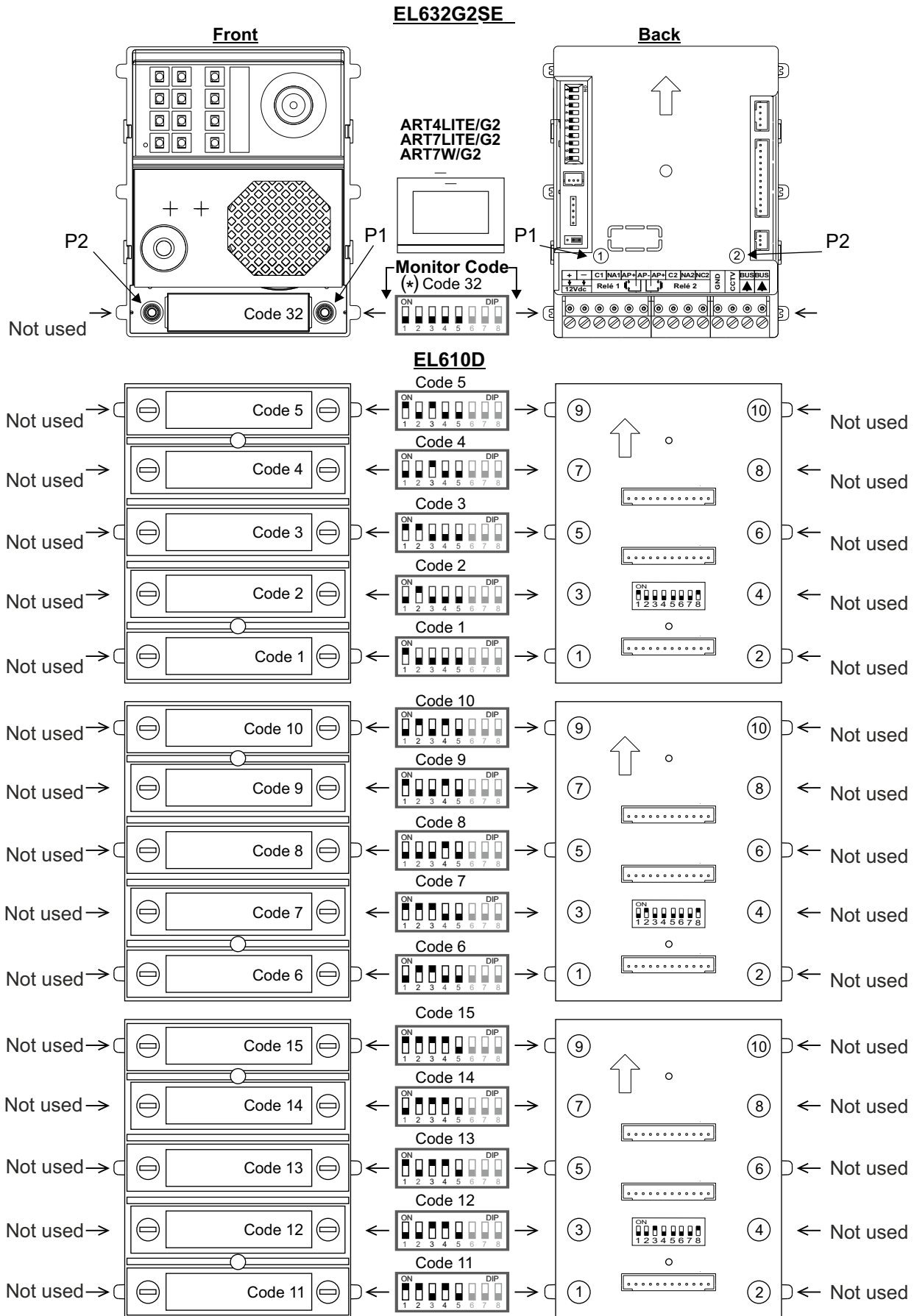

(*) Mixed installations with monitors/ terminales, the "code 32" in ART1 terminal is:  Continued overleaf

NEXA MODULAR G2+ AUDIO AND VIDEO DOOR ENTRY SYSTEM - BUILDING 13

INSTALLATION OF THE DOOR PANEL

Continued from previous page.

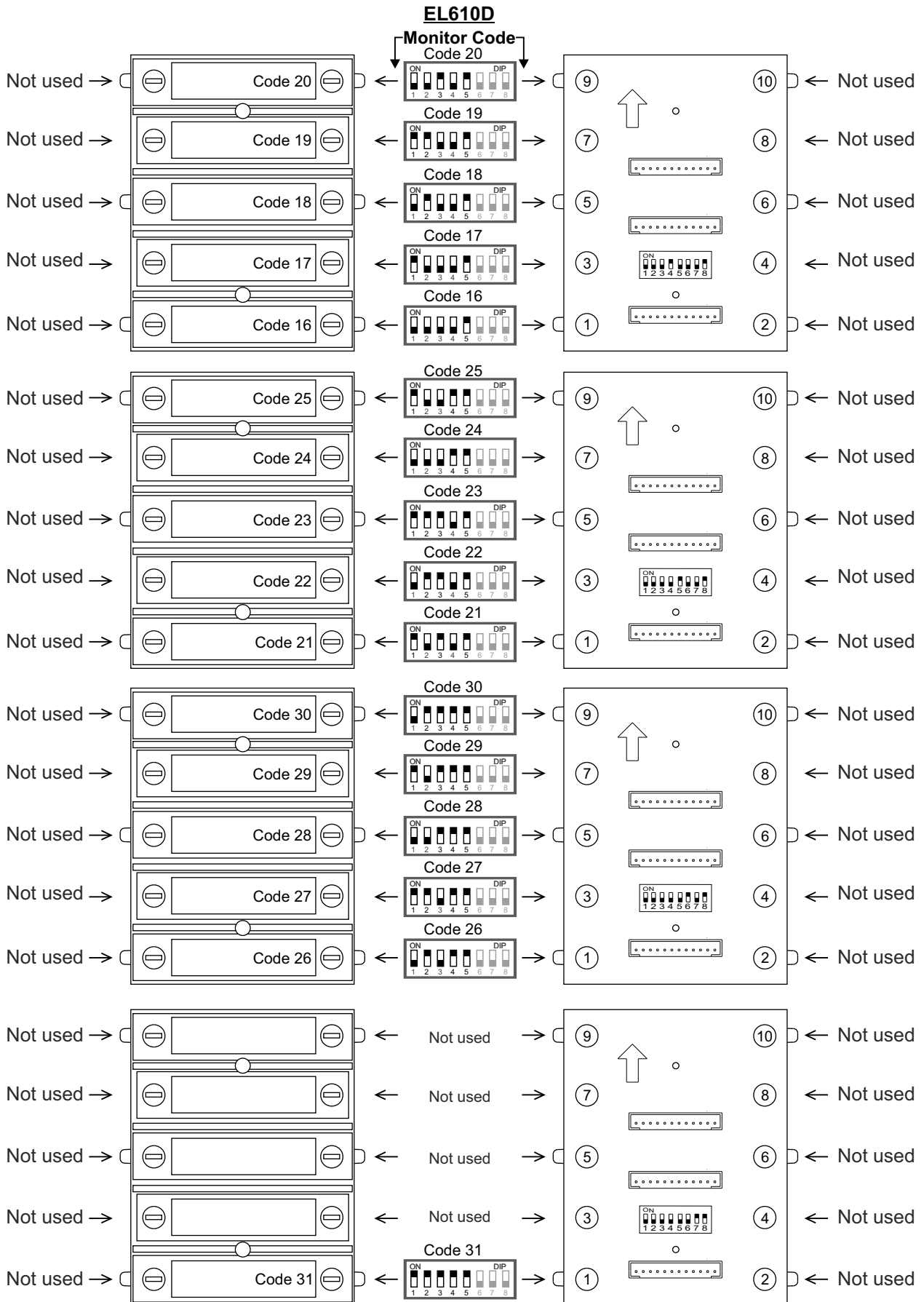

NEXA MODULAR G2+ AUDIO AND VIDEO DOOR ENTRY SYSTEM - BUILDING 14

INSTALLATION OF THE DOOR PANEL

Configuring the button code (audio only installation up to 128 terminals/apartments with EL642 G2+ sound module):

The EL610D button module needs to be configured in order to assign a call code to the buttons. Carry out this configuration with the DIP switch located at the back of the module.

Depending on the configuration option selected, the buttons will be assigned with a certain call code.

To configure the call code on the monitors. It is worth noting the call code of each button, as shown in the table below.

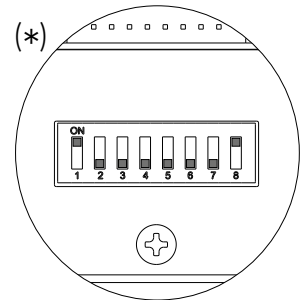

IMPORTANT: Only audio installation up to 128 terminals/apartments with EL642 G2+ sound module.

EL610D button module

Double button module codes

		DIP switch								Button code									
		Dip1	Dip2	Dip3	Dip4	Dip5	Dip6	Dip7	Dip8	P1	P2	P3	P4	P5	P6	P7	P8	P9	P10
Module configuration option	1	On	Off	Off	Off	Off	Off	Off	On	1	2	3	4	5	6	7	8	9	10
	2	Off	On	Off	Off	Off	Off	Off	On	11	12	13	14	15	16	17	18	19	20
	3	Off	Off	On	Off	Off	Off	Off	On	21	22	23	24	25	26	27	28	29	30
	4	Off	Off	Off	On	Off	Off	Off	On	31	32	33	34	35	36	37	38	39	40
	5	Off	Off	Off	Off	On	Off	Off	On	41	42	43	44	45	46	47	48	49	50
	6	Off	Off	Off	Off	Off	On	Off	On	51	52	53	54	55	56	57	58	59	60
	7	Off	Off	Off	Off	Off	Off	On	On	61	62	63	64	65	66	67	68	69	70
	8	On	Off	Off	Off	Off	Off	Off	Off	71	72	73	74	75	76	77	78	79	80
	9	Off	On	Off	Off	Off	Off	Off	Off	81	82	83	84	85	86	87	88	89	90
	10	Off	Off	On	Off	Off	Off	Off	Off	91	92	93	94	95	96	97	98	99	100
	11	Off	Off	Off	On	Off	Off	Off	Off	101	102	103	104	105	106	107	108	109	110
	12	Off	Off	Off	Off	On	Off	Off	Off	111	112	113	114	115	116	117	118	119	120
	13	Off	Off	Off	Off	Off	On	Off	Off	121	122	123	124	125	126	127	128	-	-

(1) P1- P10: Button 1 - button 10

Note: EL642 G2+ module, factory default with the code "32" in P1 and "31" in P2.

Note: EL642 G2+ module, P1 and P2 push buttons must be changed the call code (for example "128" in P1 and "127" in P2), see page 28.

Important: Select a different configuration option for each EL610D module.

(*) Factory default.

NEXA MODULAR G2+ AUDIO AND VIDEO DOOR ENTRY SYSTEM - BUILDING 15

INSTALLATION OF THE DOOR PANEL

Continued from previous page.

EL610D button module Single button module codes

		DIP switch								Button code					(1)
		Dip1	Dip2	Dip3	Dip4	Dip5	Dip6	Dip7	Dip8	P1	P3	P5	P7	P9	
Module configuration option	1	On	Off	Off	Off	Off	Off	Off	On	1	2	3	4	5	(*)
	2	Off	On	Off	Off	Off	Off	Off	On	6	7	8	9	10	
	3	Off	Off	On	Off	Off	Off	Off	On	11	12	13	14	15	
	4	Off	Off	Off	On	Off	Off	Off	On	16	17	18	19	20	
	5	Off	Off	Off	Off	On	Off	Off	On	21	22	23	24	25	
	6	Off	Off	Off	Off	Off	On	Off	On	26	27	28	29	30	
	7	Off	Off	Off	Off	Off	Off	On	On	31	32	33	34	35	
	8	On	Off	Off	Off	Off	Off	Off	Off	36	37	38	39	40	
	9	Off	On	Off	Off	Off	Off	Off	Off	41	42	43	44	45	
	10	Off	Off	On	Off	Off	Off	Off	Off	46	47	48	49	50	
	11	Off	Off	Off	On	Off	Off	Off	Off	51	52	53	54	55	
	12	Off	Off	Off	Off	On	Off	Off	Off	56	57	58	59	60	
	13	Off	Off	Off	Off	Off	On	Off	Off	61	62	63	64	65	
	14	Off	Off	Off	Off	Off	Off	On	Off	66	67	68	69	70	

(1)P1- P10: Button 1 - button 10

Note: EL642 G2+ module, factory default with the code "32" in P1.

Note: EL642 G2+ module, P1 push button must be changed the call code for example "71" in P1, (see page 28).

Important: Select a different configuration option for each EL610D module.

(*) Factory default.

NEXA MODULAR G2+ AUDIO AND VIDEO DOOR ENTRY SYSTEM - BUILDING 16

INSTALLATION OF THE DOOR PANEL

Configuring double button module codes (up to 128 terminals/apartments):

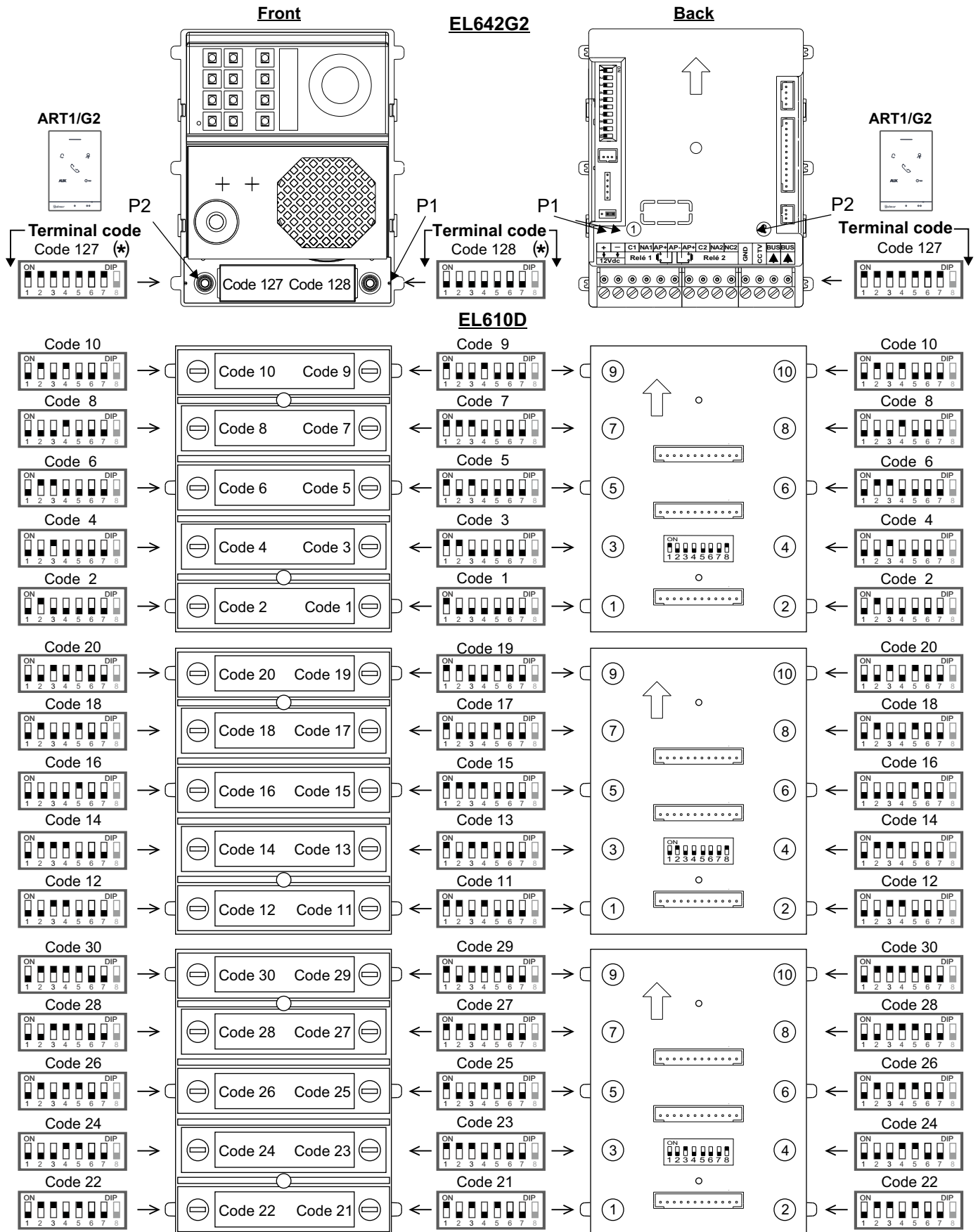

(*) Note: EL642 G2+ module, P1 and P2 push buttons must be changed the call code (for example "128" in P1 and "127" in P2), see page 28.

Continued overleaf

NEXA MODULAR G2+ AUDIO AND VIDEO DOOR ENTRY SYSTEM - BUILDING 17

INSTALLATION OF THE DOOR PANEL

Continued from previous page.

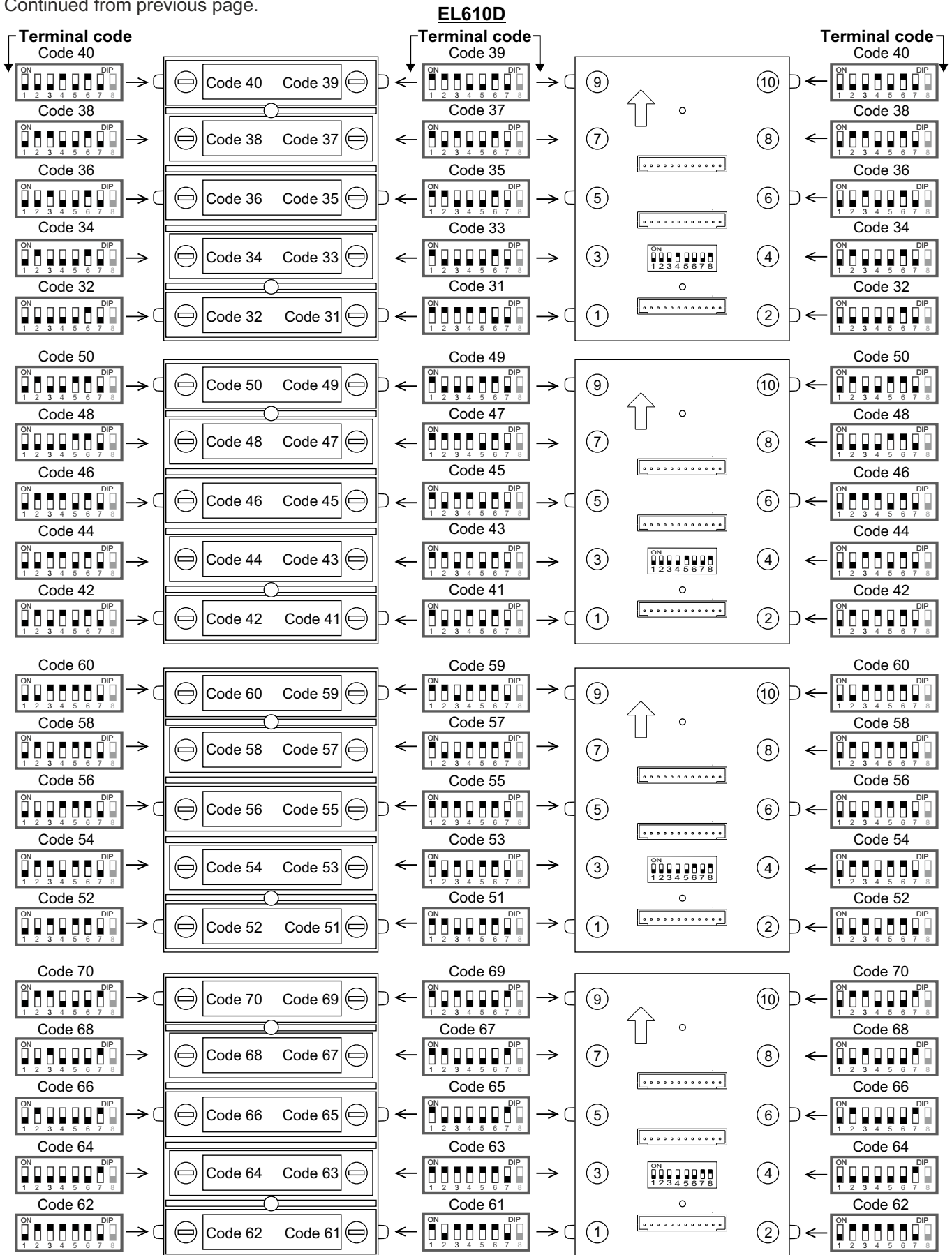

Continued overleaf

INSTALLATION OF THE DOOR PANEL

Continued from previous page.

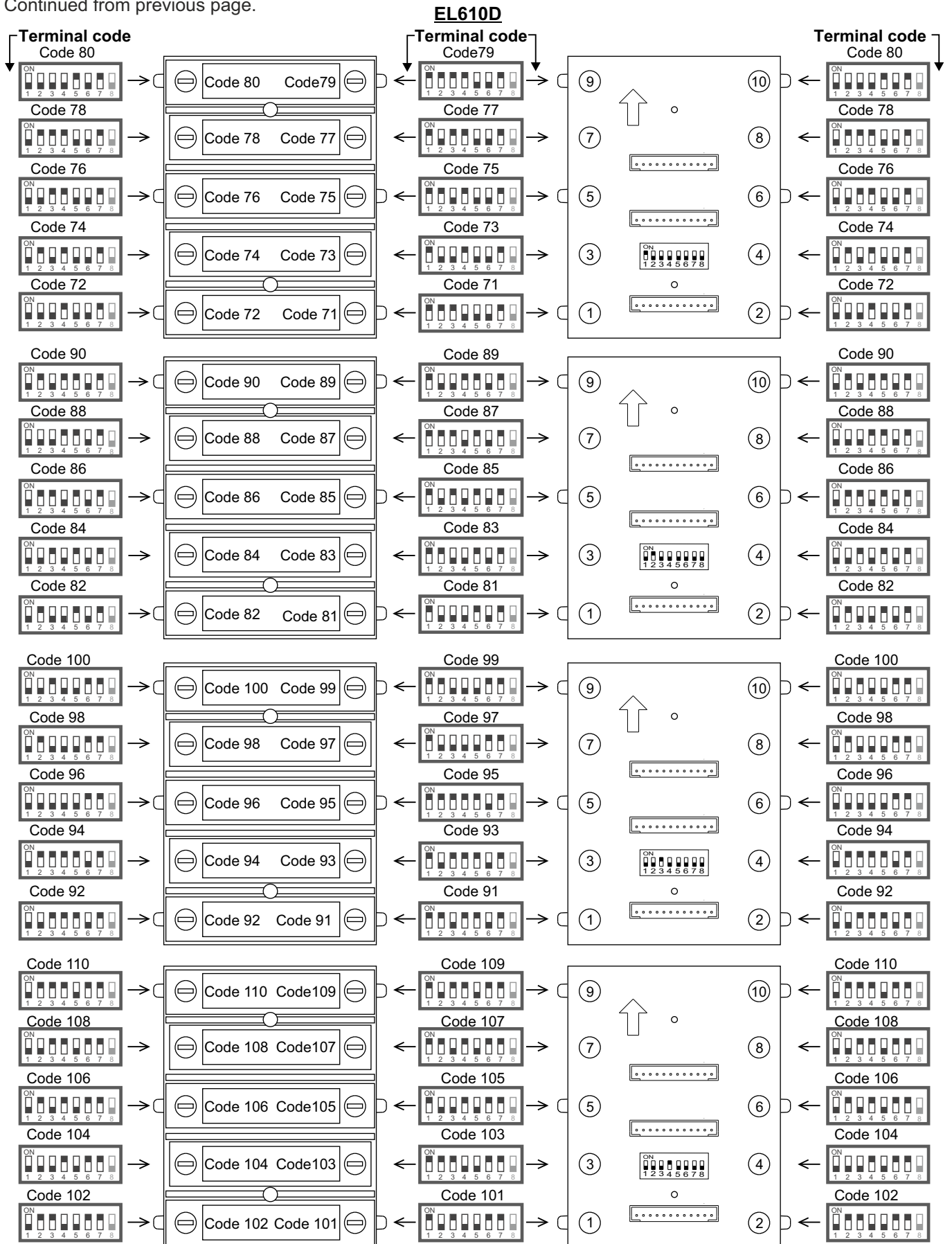

NEXA MODULAR G2+ AUDIO AND VIDEO DOOR ENTRY SYSTEM - BUILDING 19

INSTALLATION OF THE DOOR PANEL

Continued from previous page.

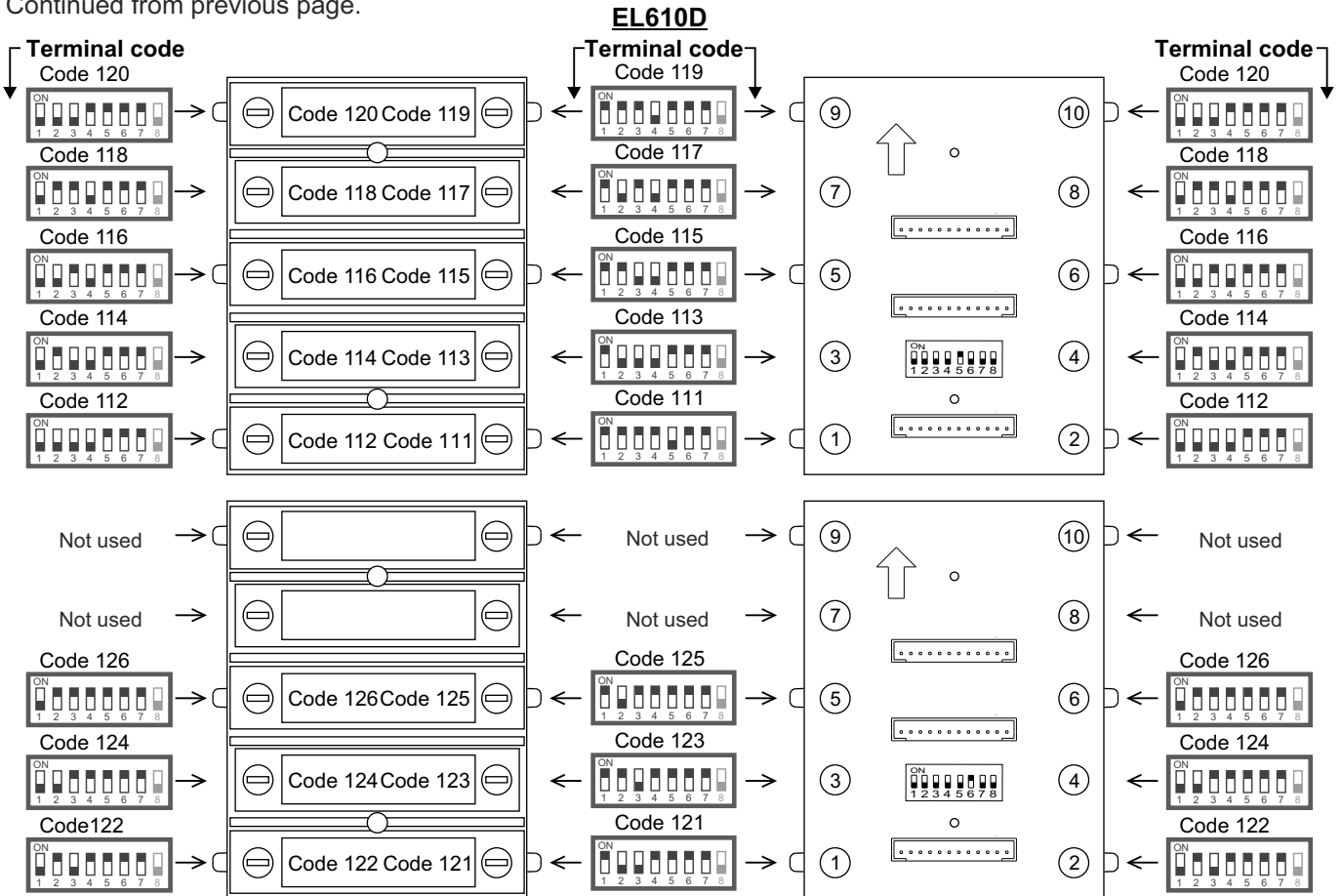

NEXA MODULAR G2+ AUDIO AND VIDEO DOOR ENTRY SYSTEM - BUILDING 21

INSTALLATION OF THE DOOR PANEL

Continued from previous page.

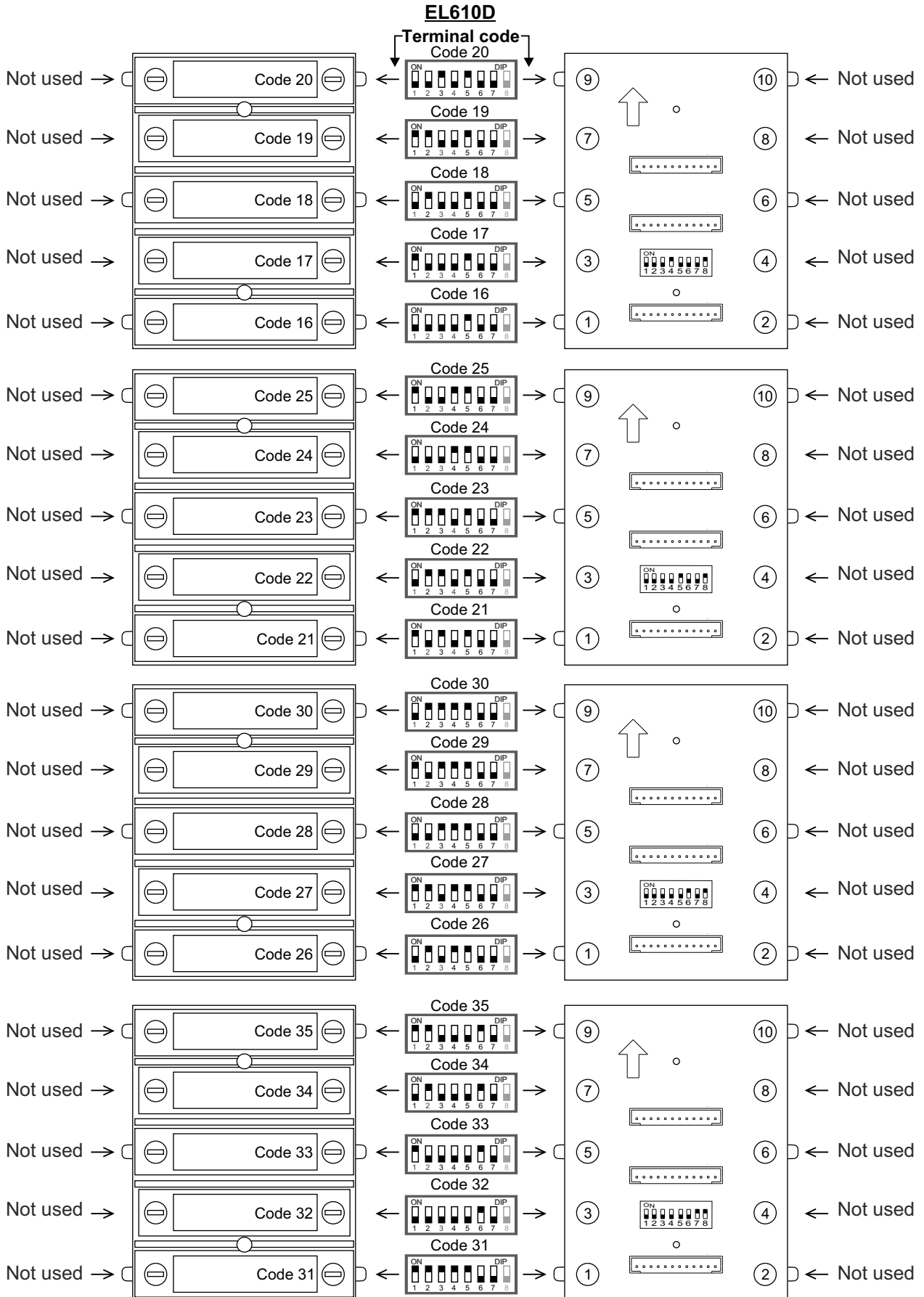

Continued overleaf

NEXA MODULAR G2+ AUDIO AND VIDEO DOOR ENTRY SYSTEM - BUILDING 22

INSTALLATION OF THE DOOR PANEL

Continued from previous page.

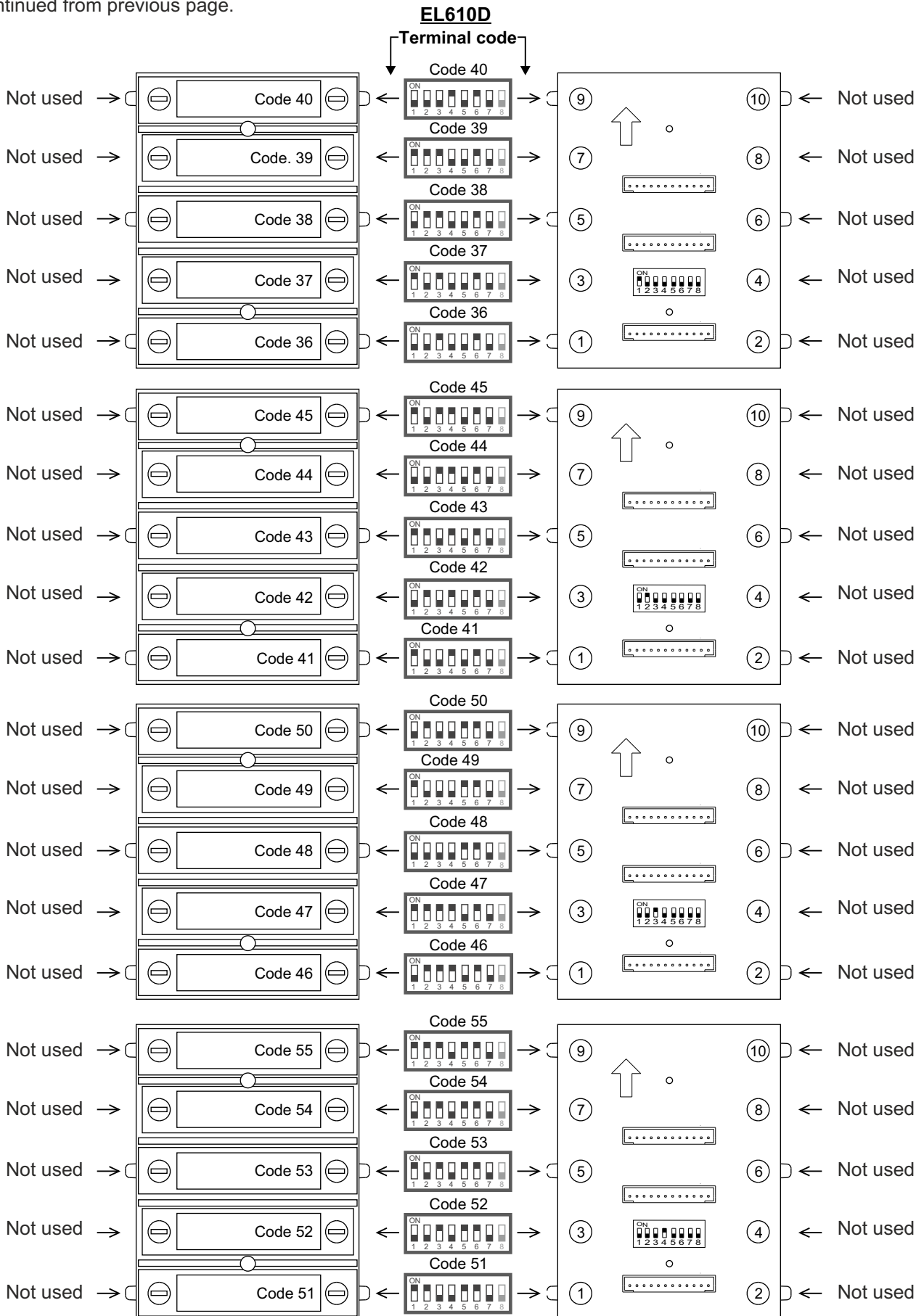

Continued overleaf

NEXA MODULAR G2+ AUDIO AND VIDEO DOOR ENTRY SYSTEM - BUILDING 23

INSTALLATION OF THE DOOR PANEL

Continued from previous page.

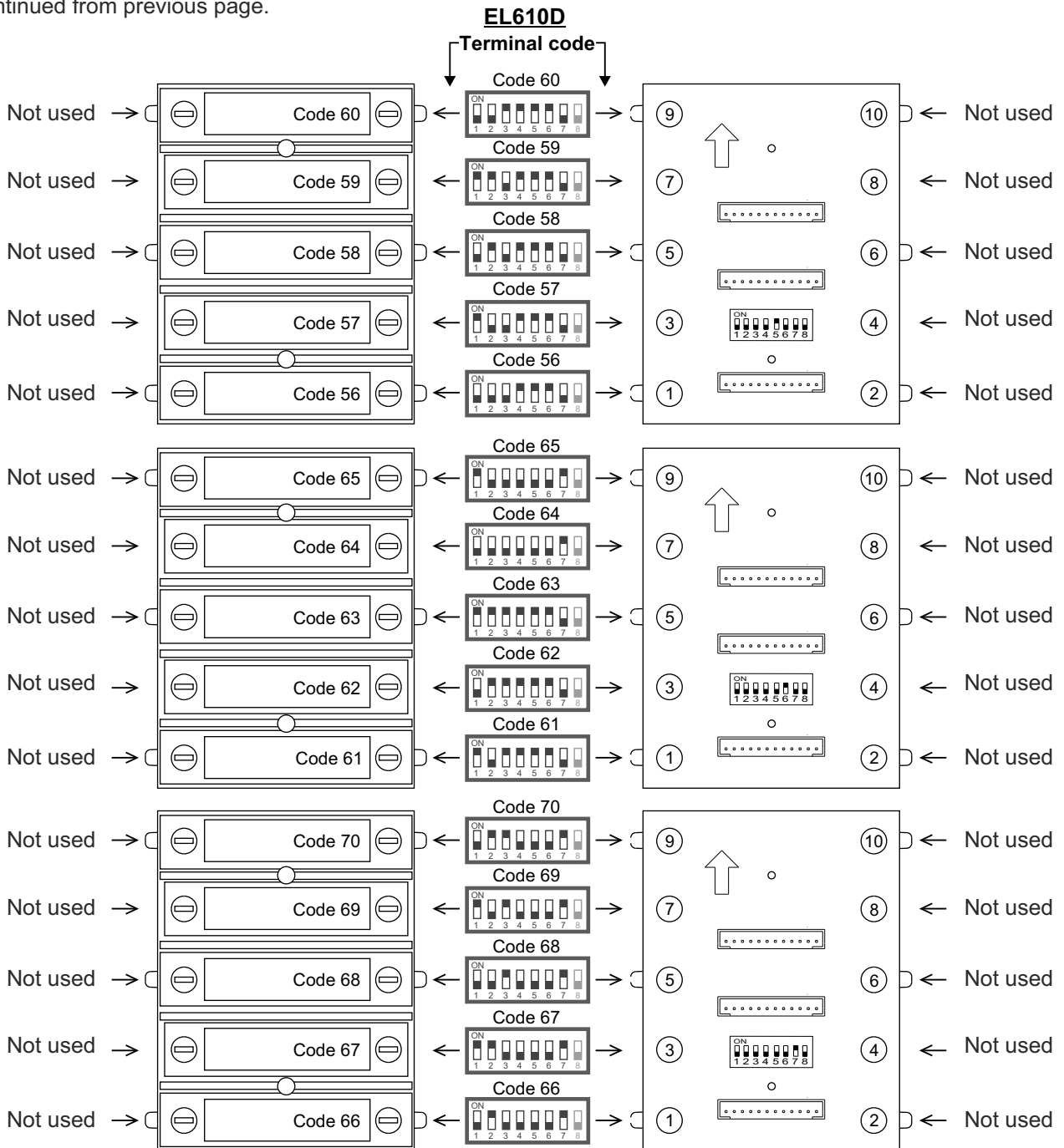





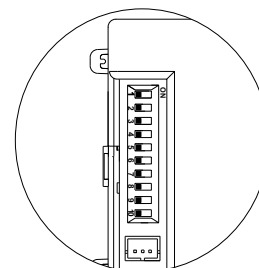

NEXA MODULAR G2+ AUDIO AND VIDEO DOOR ENTRY SYSTEM - BUILDING 24

INSTALLATION OF THE DOOR PANEL

Description of the EL632G2SE sound module DIP switch: (*)

The DIP switch is located on the top left side of the back of the module.



- (*)  Door panel address:
Dip switches 1 & 2 leave to OFF position (address 1).
- (*)  Leave to the OFF position for door panels with double button and set to ON for door panels with single button.
- (*)  To Select the vocal synthesis language or tones mode (for call in progress, missed call, door open and call finished) of the door panel. Factory default: vocal synthesis with Spanish language (see page 27).
- (*)  Leave to OFF, no function.
- (*)  To program the P1 and P2 buttons with another call code (see page 28).
Remember: Leave Dip 10 to OFF after finishing the work to change the call code.



(*) **Factory default.**

Audio level jumper description (vocal synthesis and tones mode) EL632G2SE module:

Audio level jumper is located on the left side of the back module.

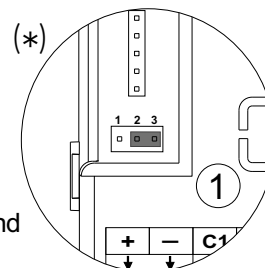
The jumper for volume control, allows to select between a minimum, maximum or mute of the vocal synthesis and tones mode from the door panel.



- (*)  Jumper placed between 2 and 3, set to minimum volume the vocal synthesis and tones from the door panel.
-  Jumper placed between 1 and 2, set to maximum volume the vocal synthesis and tones from the door panel.
-  Jumper removed, set to mute volume the vocal synthesis and tones from the door panel.

(*) **Factory default.**

Description of the LED lights (low light conditions) EL632G2SE module:

The door panel lighting LEDs will turn on during a call if the door panel lighting at that moment is low. This enables the user to view the person who has called from the apartment monitor.

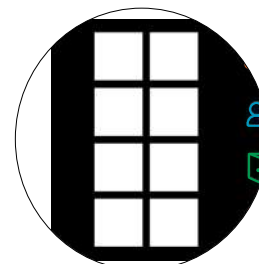







NEXA MODULAR G2+ AUDIO AND VIDEO DOOR ENTRY SYSTEM - BUILDING 25

INSTALLATION OF THE DOOR PANEL

Description of the visual signals on the door panel (EL632G2SE module):

Visual signals on the door panel for people with impaired hearing:

- While calling: LED  will illuminate during in call process.
- During communication: LED  will illuminate during the communication process.
- During door release: LED  will illuminate during door release.
- End of communication: LED  will turn off.
- Calling at one door panel while another door panel is communicating (if there is more than one door panel): LED  will illuminate for 3 seconds.
- While calling and the monitor is in "Do not disturb" mode: LED  will illuminate during in call process.
- While calling (apartment with no monitor or audio terminal): No visual indication.



Description of the vocal synthesis (audible signals on the door panel) EL632G2SE :

Audible signals on the door panel for people with impaired vision.

If vocal synthesis is enabled on the sound module (see page 27 for configuration), the following voice messages can be heard on the door panel:

- While calling: "Call is in progress".
- During door release: "Door Opened".
- End of communication: "Communication is finished".
- Calling at one door panel while another door panel is communicating (if there is more than one door panel): "System is busy, try later".
- While calling and the monitor is in "Do not disturb" mode: "Call is in progress".
- While calling (apartment with no monitor or audio terminal): "Call is in progress - Resident unavailable".

Tones mode description (audible signals on the door panel) EL632G2SE:

Tones mode audible signals on the door panel.

If tones mode is enabled on the sound module (see page 27 for configuration), the following tones can be heard on the door panel:

- While calling: 2 long tones.
- During door release: 1 long tone.
- End of communication: No audible signals.
- Calling at one door panel while another door panel is communicating (if there is more than one door panel): 5 short tones.
- While calling and the monitor is in "Do not disturb" mode: 2 long tones.
- While calling (apartment with no monitor or audio terminal): 2 long tones and 5 short tones.

Description of the P1 and P2 external buttons (EL632G2SE sound module):

The connector is located on the right side of the back sound module.

Insert the connection cable supplied with module to connect the external call buttons P1 and P2 of the sound module.

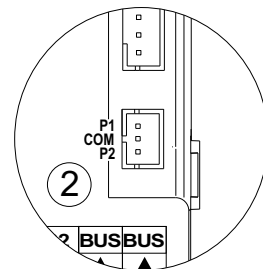

External button P1

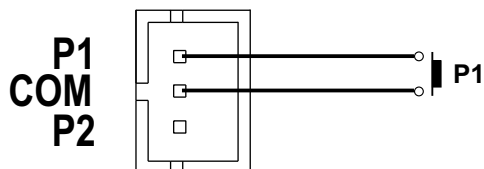

External button P2

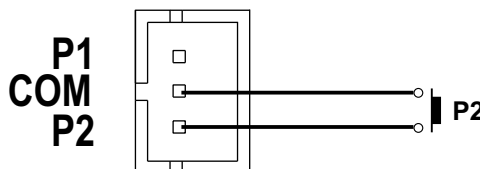

NEXA MODULAR G2+ AUDIO AND VIDEO DOOR ENTRY SYSTEM - BUILDING 26

INSTALLATION OF THE DOOR PANEL

Description of the connector to CD-NEXA/G2+ digital converter module (EL632G2SE)

The connector to Nexa Bus through the **CD-NEXA/G2+ converter**, is located at the upper right side of the back of the sound module.

Insert the connection cable that it is supplied with the sound module and the other end of the connection cable in the CD-NEXA/G2+ converter and from CD-NEXA/G2+ converter to connect with the next Nexa modules:

- ⇒ N3403/AL: Connect to the module to add to the system with a graphic display module coded panel.
- ⇒ N3301/AL: Connect to the module to add to the system with an access control module and coded panel.
- ⇒ N3301A/AL: Connect to the module to add to the system with an alphabetic module.
- ⇒ EL4502/NFC: Connect to the module to add the system with an NFC access control.
- ⇒ EL3002: Connect to power the illumination.
- ⇒ CD-NEXA/BT: Connect to the module to add to the system with a configuration RFC interface (wireless device of 2,4 Ghz). Only for N3301 and N3403 modules.

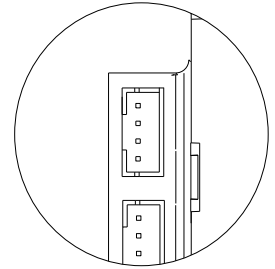

Note: Up to 3 Nexa modules can be connected (without additional power supply).
For more information contact with our technical support department.

Connection with EL3002 illumination modules (EL632G2SE sound modules):

Insert the connection cable that it is supplied with CD-NEXA G2 converter, in the sound module connector and the other end of the connection cable in CN2 connector of the CD-NEXA G2 converter, then insert the connection cable that is supplied with EL3002 illumination module in CN3 connector of the CD-NEXA G2 converter and the other end of the connection cable in any of the three connectors placed at the bottom of the EL3002 illumination module. To connect to other illumination modules use any of the two free connectors.

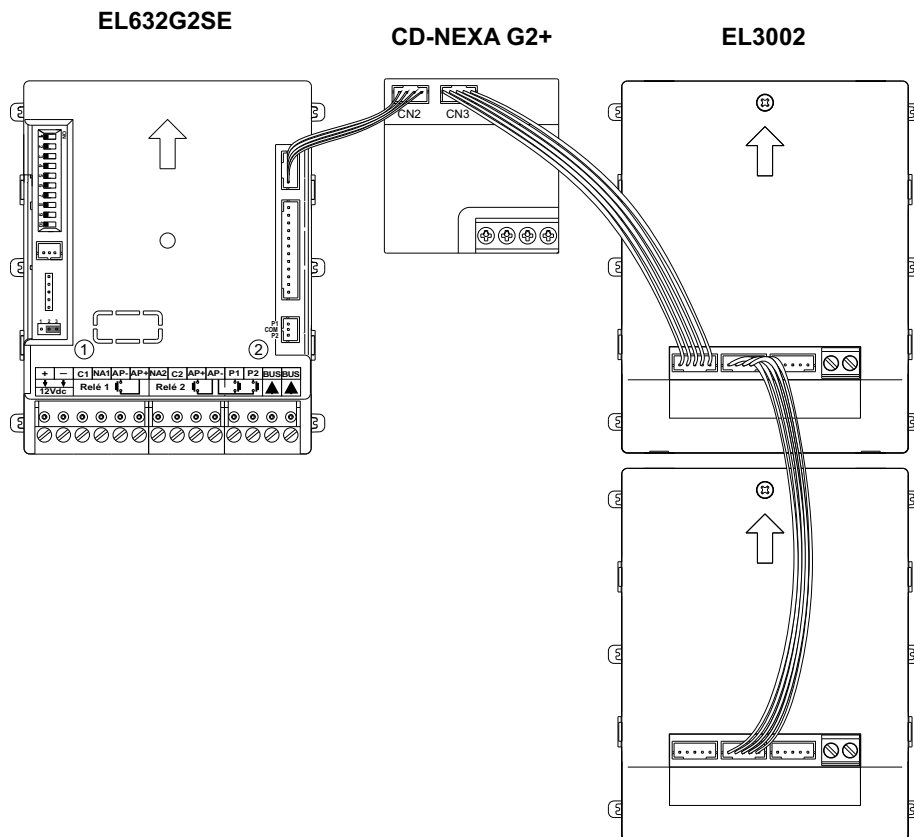

NOTE: Only the EL632G2SE sound module must be connected to power supply. The EL3002 illumination module takes the power through it has been connected to the CD-NEXA G2 converter and the sound module, (see above connection drawing).

NEXA MODULAR G2+ AUDIO AND VIDEO DOOR ENTRY SYSTEM - BUILDING 27

INSTALLATION OF THE DOOR PANEL

Selecting vocal synthesis language or tones mode (EL632G2SE module):

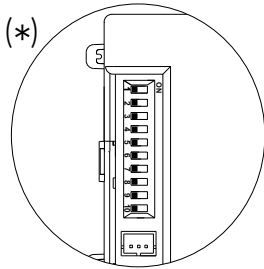

The configuration Dip switch is located on the top left side of the back of the module.

If you want to change the language of the vocal synthesis or select the tones mode of the door panel, configure dips 4 to 8 of the configuration Dip switch (page 24), see the following selection table:

Vocal Synthesis	Dip4	Dip5	Dip6	Dip7	Dip8
(*) Español	OFF	OFF	OFF	OFF	OFF
Catalán	ON	OFF	OFF	OFF	OFF
Gallego	OFF	ON	OFF	OFF	OFF
Vasco	ON	ON	OFF	OFF	OFF
Tones Mode	OFF	OFF	ON	OFF	OFF
Arabic	ON	OFF	ON	OFF	OFF
Bulgarian	OFF	ON	ON	OFF	OFF
Croatian	ON	ON	ON	OFF	OFF
Czech	ON	OFF	OFF	ON	OFF
Dansk	ON	OFF	OFF	ON	OFF
Dutch	OFF	ON	OFF	ON	OFF
English	ON	ON	OFF	ON	OFF
French	OFF	OFF	ON	ON	OFF
German	ON	OFF	ON	ON	OFF
Greek	OFF	ON	ON	ON	OFF
Hungarian	ON	ON	ON	ON	OFF
Italian	OFF	OFF	OFF	OFF	ON
Norwegian	ON	OFF	OFF	OFF	ON
Polish	OFF	ON	OFF	OFF	ON
Portuguese	ON	ON	OFF	OFF	ON
Romanian	OFF	OFF	ON	OFF	ON
Russian	ON	OFF	ON	OFF	ON
Serbian	OFF	ON	ON	OFF	ON
Slovak	ON	ON	ON	OFF	ON
Swedish	OFF	OFF	OFF	ON	ON
Turkish	ON	OFF	OFF	ON	ON



(*) Factory default.

NEXA MODULAR G2+ AUDIO AND VIDEO DOOR ENTRY SYSTEM - BUILDING 28

INSTALLATION OF THE DOOR PANEL

Change the call code of the P1 and P2 button of the EL632G2SE module:

If you want to change the call code of button P1 of the sound module, follow these steps:
(Factory value P1 = 32).

- 1- In the sound module configuration Dip switch (see page 24), set **Dip8 to OFF**.
- 2- Then: **Video door panel set Dip1 to Dip6 (Dip7 must be OFF)** the new call code (address 1 to 32). **Audio door panel set Dip1 to Dip7** the new call code (address 1 to 128).

The Dip switches placed in the OFF position have a value of zero and in the ON position they have been assigned the values in the attached table.

The calling code will be equal to the sum of the values of the Dip switches set to ON.

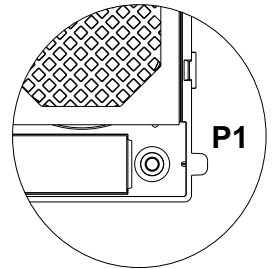

Important (Video door panel):

Apartment 1 (Dip1 to ON & Dip2-Dip6 to OFF)
Apartment 32 (Dip1-Dip5 a OFF & Dip6 to ON)

Table of values

Switch number:	1	2	3	4	5	6
Value when ON:	1	2	4	8	16	32

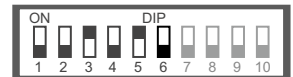

Example: $0 + 0 + 4 + 0 + 16 + 0 = 20$

Important (Audio door panel):

Apartment 1 (Dip1 to ON & Dip2-Dip7 to OFF)
Apartment 128 (Dip1-Dip7 to OFF)

Table of values

Switch number:	1	2	3	4	5	6	7
Value when ON:	1	2	4	8	16	32	64



Example: $0 + 0 + 4 + 0 + 16 + 0 + 0 = 20$

- 3- Set the **Dip 10 to ON**, a tone will confirm that the new call code has been successfully programmed.
- 4- Set the **Dip 10 to OFF** and Dips 1 to 8 as previously configured (address door panel, double / single button and language or tone mode).

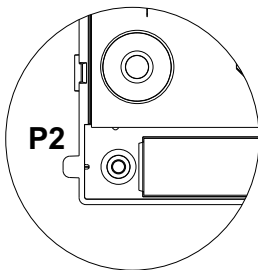

If you want to change the call code of button P2 of the sound module, follow these steps:
(Factory value P2 = 31).

- 1- In the sound module configuration Dip switch (see page 24), set **Dip8 to ON**.
- 2- Then: **Video door panel set Dip1 to Dip6 (Dip7 must be OFF)** the new call code (address 1 to 32). **Audio door panel set Dip1 to Dip7** the new call code (address 1 to 128).

The Dip switches placed in the OFF position have a value of zero and in the ON position they have been assigned the values in the attached table.

The calling code will be equal to the sum of the values of the Dip switches set to ON.

Important (Video door panel):

Apartment 1 (Dip1 to ON & Dip2-Dip6 to OFF)
Apartment 32 (Dip1-Dip5 a OFF & Dip6 to ON)

Table of values

Switch number:	1	2	3	4	5	6
Value when ON:	1	2	4	8	16	32

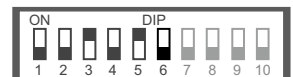

Example: $0 + 0 + 4 + 0 + 16 + 0 = 20$

Important (Audio door panel):

Apartment 1 (Dip1 to ON & Dip2-Dip7 to OFF)
Apartment 128 (Dip1-Dip7 to OFF)

Table of values

Switch number:	1	2	3	4	5	6	7
Value when ON:	1	2	4	8	16	32	64

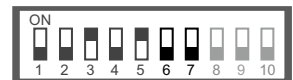

Example: $0 + 0 + 4 + 0 + 16 + 0 + 0 = 20$

- 3- Set the **Dip 10 to ON**, a tone will confirm that the new call code has been successfully programmed.
- 4- Set the **Dip 10 to OFF** and Dips 1 to 8 as previously configured (address door panel, double / single button and language or tone mode).

Final adjustments:

If after starting the system it's considered that audio volume isn't correct, proceed with the necessary adjustments as shown in the drawing.

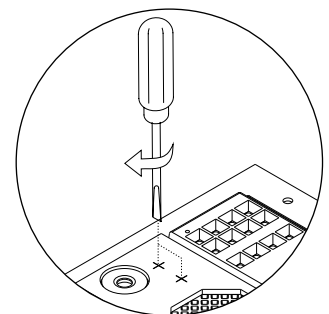
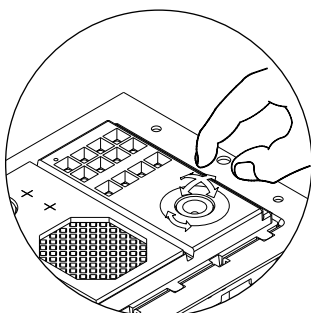

The telecamera has a pan and tilt mechanism built in to adjust the telecamera position (only EL632G2SE) .

NEXA MODULAR G2+ AUDIO AND VIDEO DOOR ENTRY SYSTEM - BUILDING 29

INSTALLATION OF THE DOOR PANEL

Closing the frame:

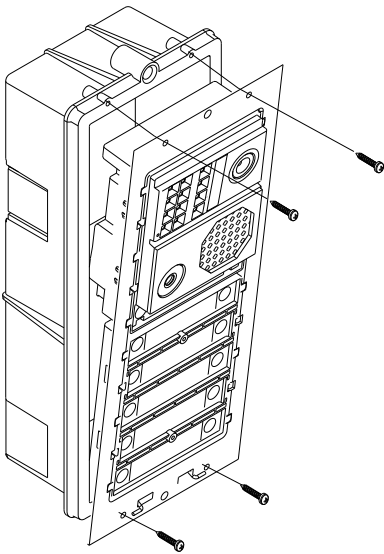

Once the wiring and configuration work is done, fix the frame to the embedding box using the screws supplied.

Important: Before closing the door panel(s) make a test call to any apartment to ensure that everything works correctly.

Inserting the button identification labels:

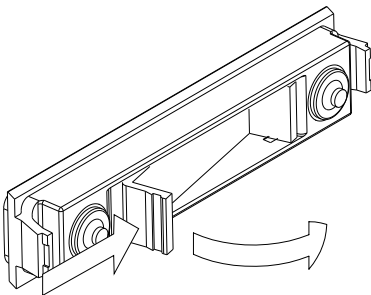

Open the label holder window.

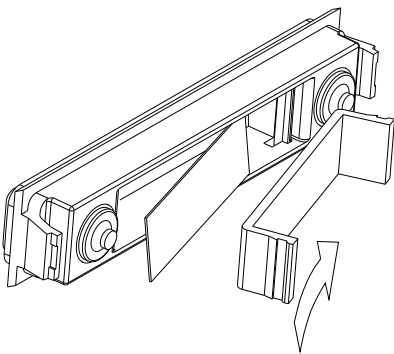

Place the label and close.

INSTALLATION OF THE DOOR PANEL

Mounting the modules of a door panel:

Insert a clip-on cover into the side profiles (from the bottom) and fix it using the screws specified (step 1) and then insert the module (step 2). If the door panel has more than one module, insert the lower module first, see figure (A).

Insert the module separator (step 3) and then the next module (step 4), see figure (B). Repeat this process on door panels with more than one module (the maximum number of modules that can be linked vertically is three).

To finish, insert the second clip-on cover (step 5) into the side profiles (from the top) and fix it using the screws specified, see figure (C).

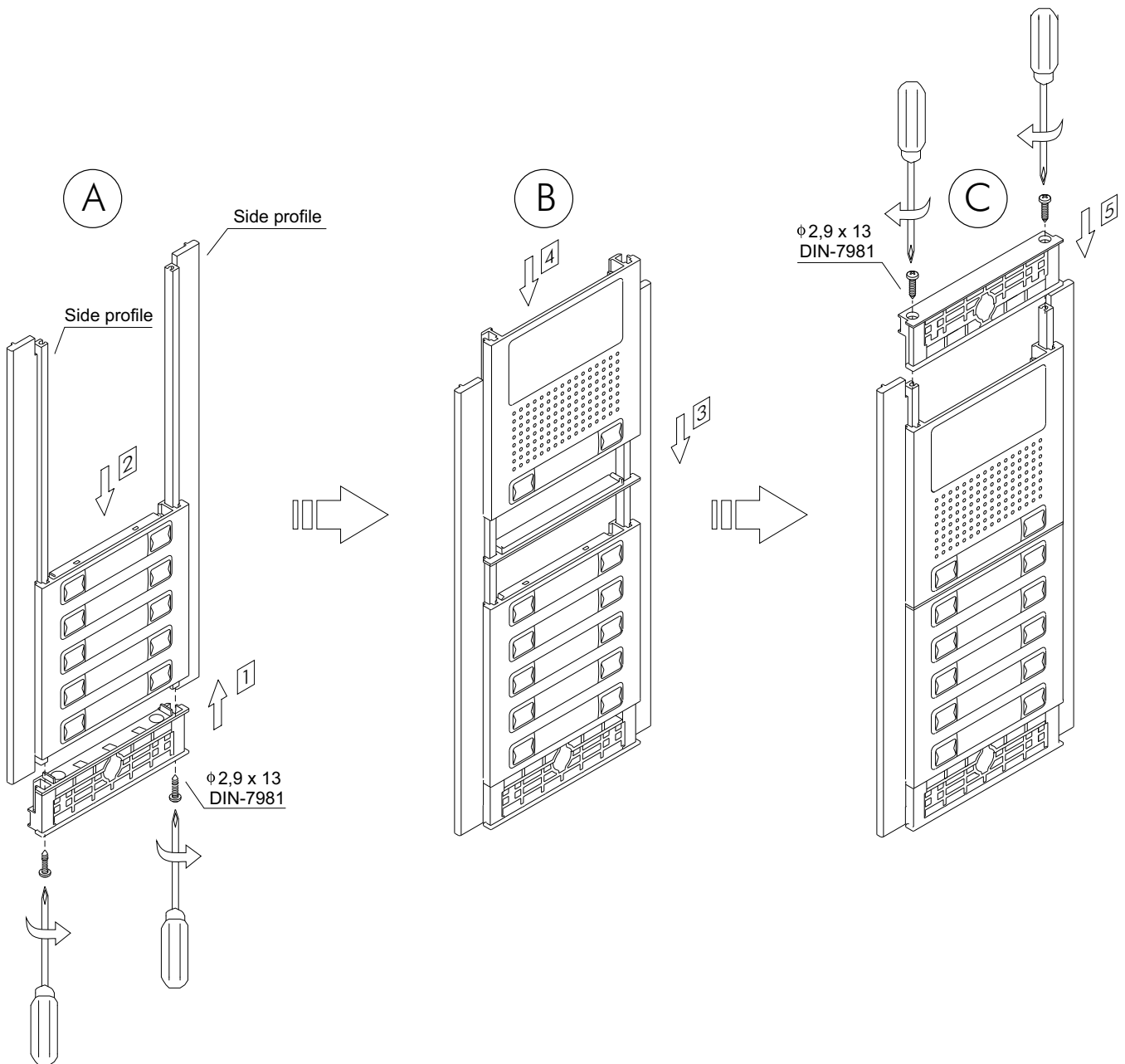

INSTALLATION OF THE DOOR PANEL

Mounting the modules of a double door panel:

Mount door panel (A) (step 1) as described in 'Mounting the modules of a door panel' (see page 30), taking into account that the bar connecting panel (A) and panel (B) must be a door panel UNE rod, see drawing below.

Insert a clip-on cover between the door panel UNE rod and the second side profile (from the bottom) and fix it using the screws specified (step 2), then insert the module (step 3). If the door panel has more than one module, insert the lower module first.

Insert the module separator (step 4) and then the next module (step 5). Repeat this process on door panels with more than one module (the maximum number of modules that can be linked vertically is three).

To finish, insert the final clip-on cover between the door panel UNE rod and the second side profile (from the top) and fix it using the screws specified (step 6).

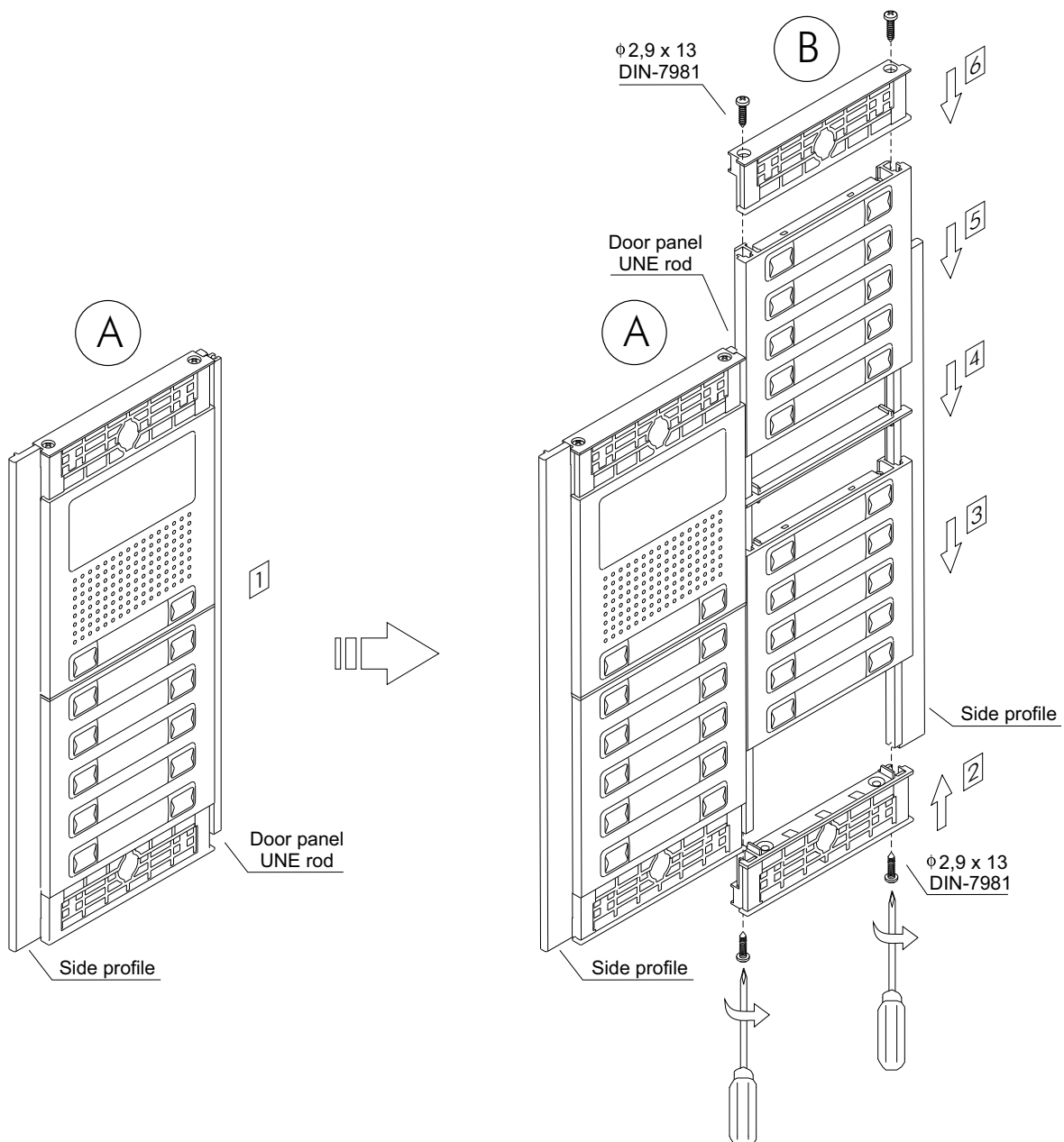

IMPORTANT: Once the adjustments are completed, stick the adhesive joint (enclosed with the N60XX CMPL end piece set) to the door panel UNE rod.

INSTALLATION OF THE DOOR PANEL

Closing the door panel:

Fix the door panel to the embedding box using the screws supplied.

To complete the fitting of the panel, attach the clip-on covers by positioning one end and then applying slight pressure to the other end until they clip into place.

Single door panel:

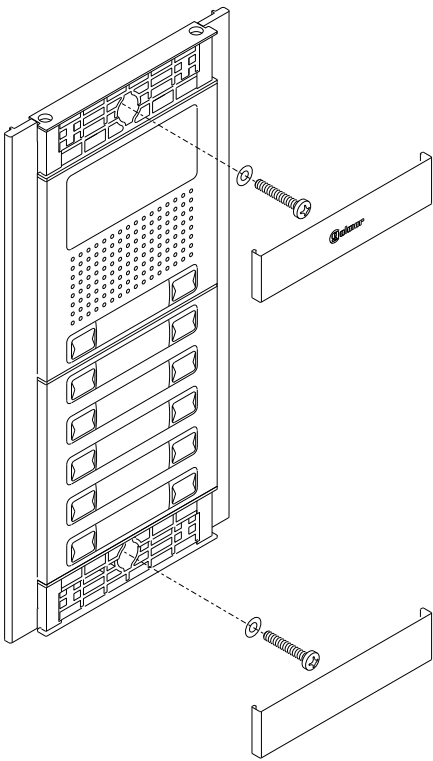

Double door panel:

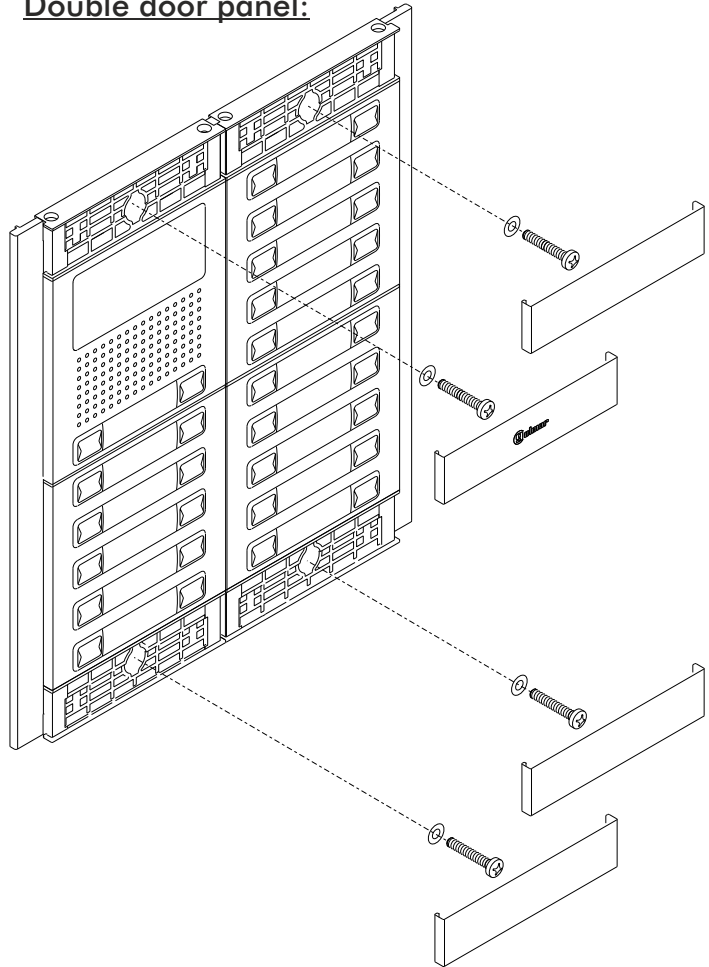

FA-G2 POWER SUPPLY

Description of the FA-G2 power supply:

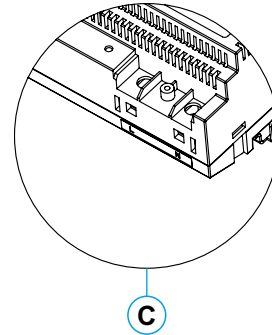
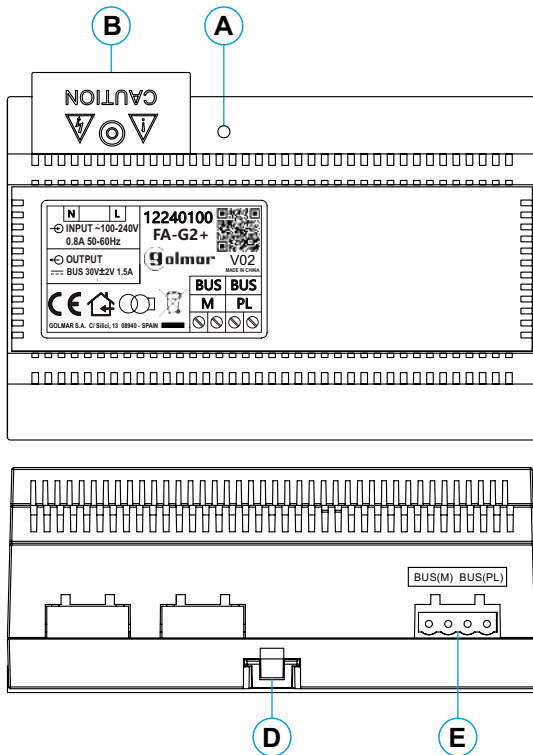

- A. On/off indicator light.
- B. Protective cover for the current input.
- C. Detail of current input terminals without protective cover.
- D. Fastening tab on DIN rail.
- E. Installation terminals.

Specification

Input Voltage:	100~240Vca
Input Frequency:	50~60 Hz
Rated Output Voltage:	30 Vdc ± 2V
Rated Output Current:	1,5A
Working Temperature:	-10°C ~ 40°C
Dimensions:	140*90*60mm

Installation of the FA-G2 power supply:

The fitting and handling of the power supply must be carried out by authorised personnel in the absence of electrical current.

Install the power supply in a dry, protected and ventilated location. Make sure that the vents are not obstructed. Use a DIN 46277 rail for fastening (8 elements).

Note that current regulations stipulate that the power supply must be protected by a circuit breaker.

To prevent electric shock, do not remove the protective cover without first disconnecting the power supply. Replace it once all connections have been made.

Connect the wires to the installation terminals following the instructions in the diagrams.

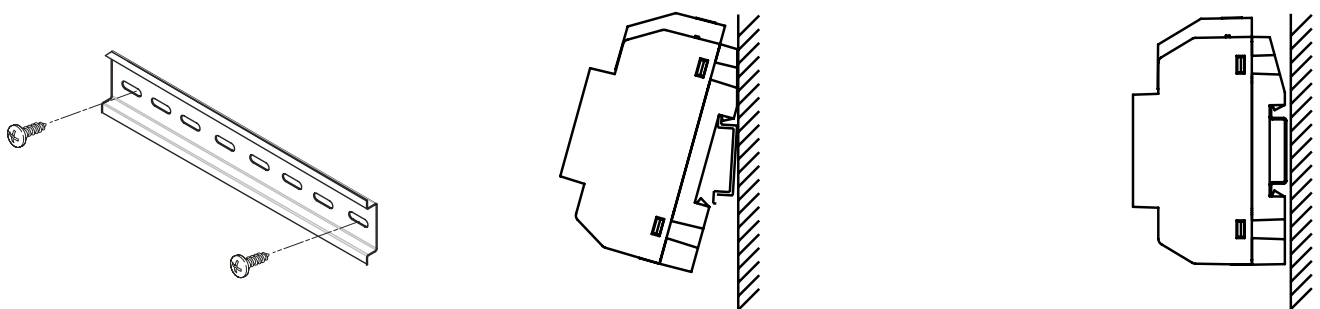

NEXA MODULAR G2+ AUDIO AND VIDEO DOOR ENTRY SYSTEM - BUILDING 34

WIRING DIAGRAMS

Audio door entry system with 128 apartments / ART1/G2 terminals

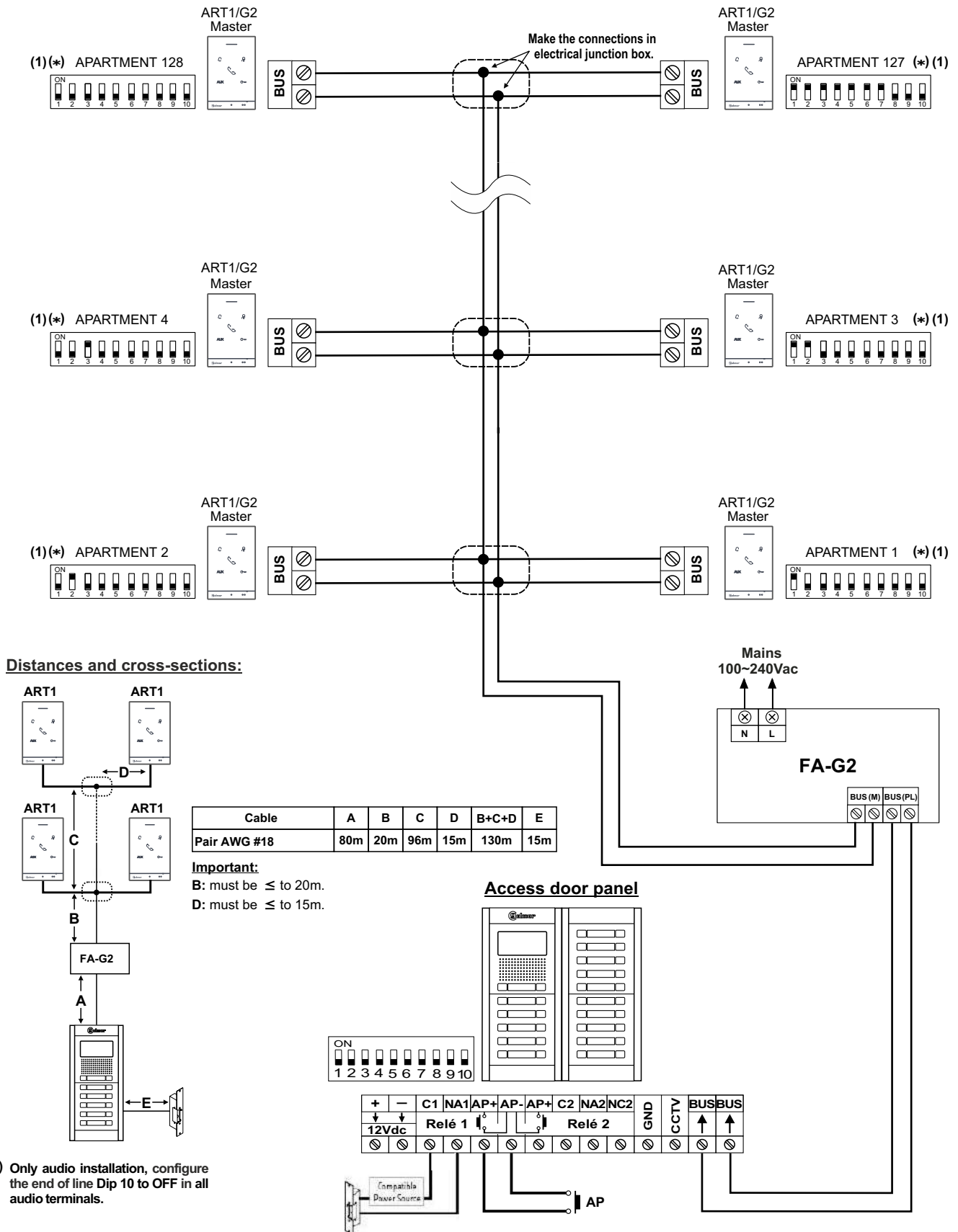

(*) Only audio installation, configure the end of line Dip 10 to OFF in all audio terminals.

Important:

(1) For more information of the ART 1/G2+ audio terminal, see the quick guide that is attached with its corresponding product.

WIRING DIAGRAMS

Audio door entry system with 8 risers of 16 apartments/ART1/G2 terminals in "IN-OUT" without distributors

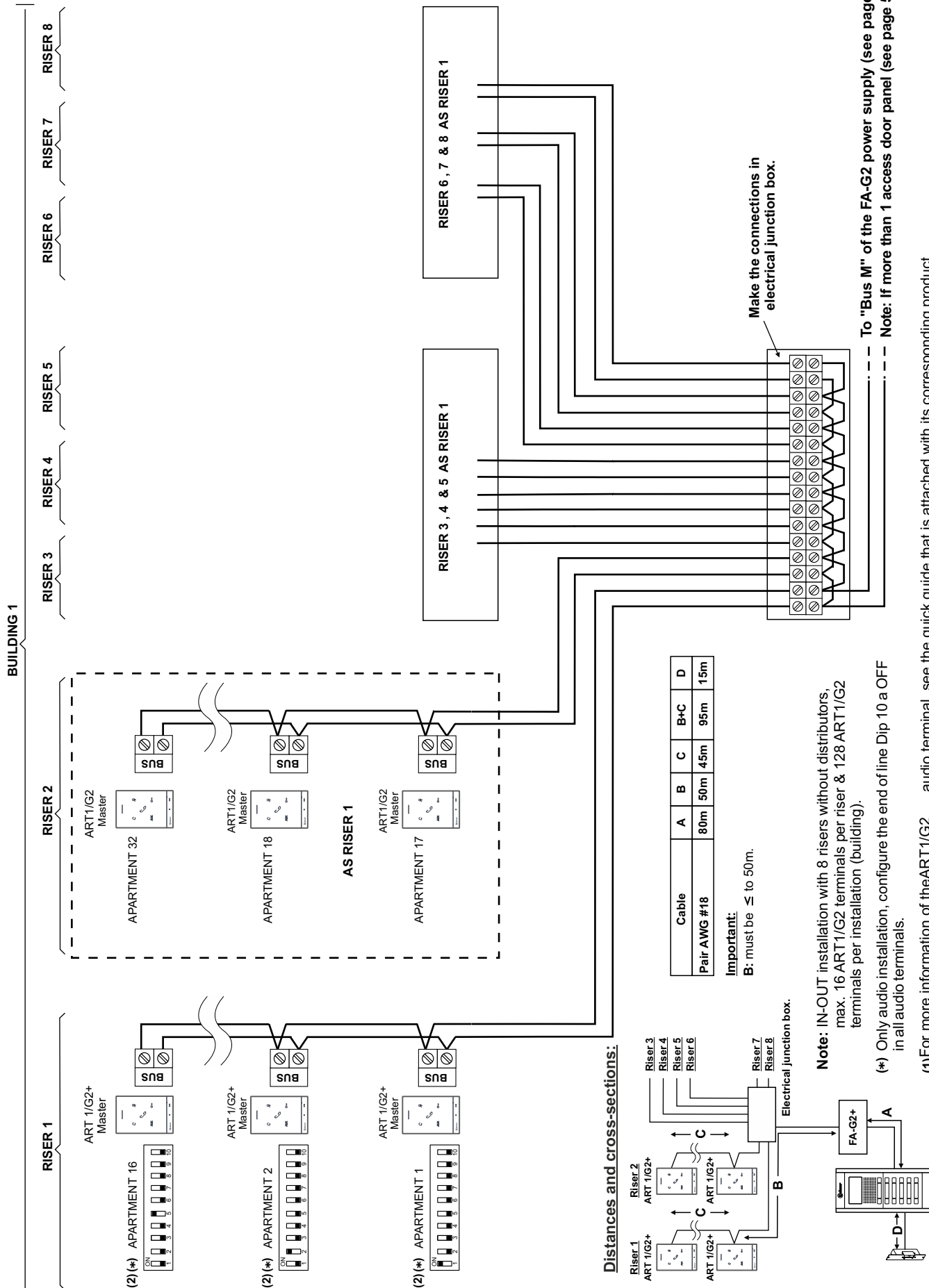

NEXA MODULAR G2+ AUDIO AND VIDEO DOOR ENTRY SYSTEM - BUILDING 36

WIRING DIAGRAMS

Video door entry system with 32 ART 4/G2+ or ART 4 LITE/G2+ monitors, 8 D4L-G2+ distributors and Golmar d.c lock release.

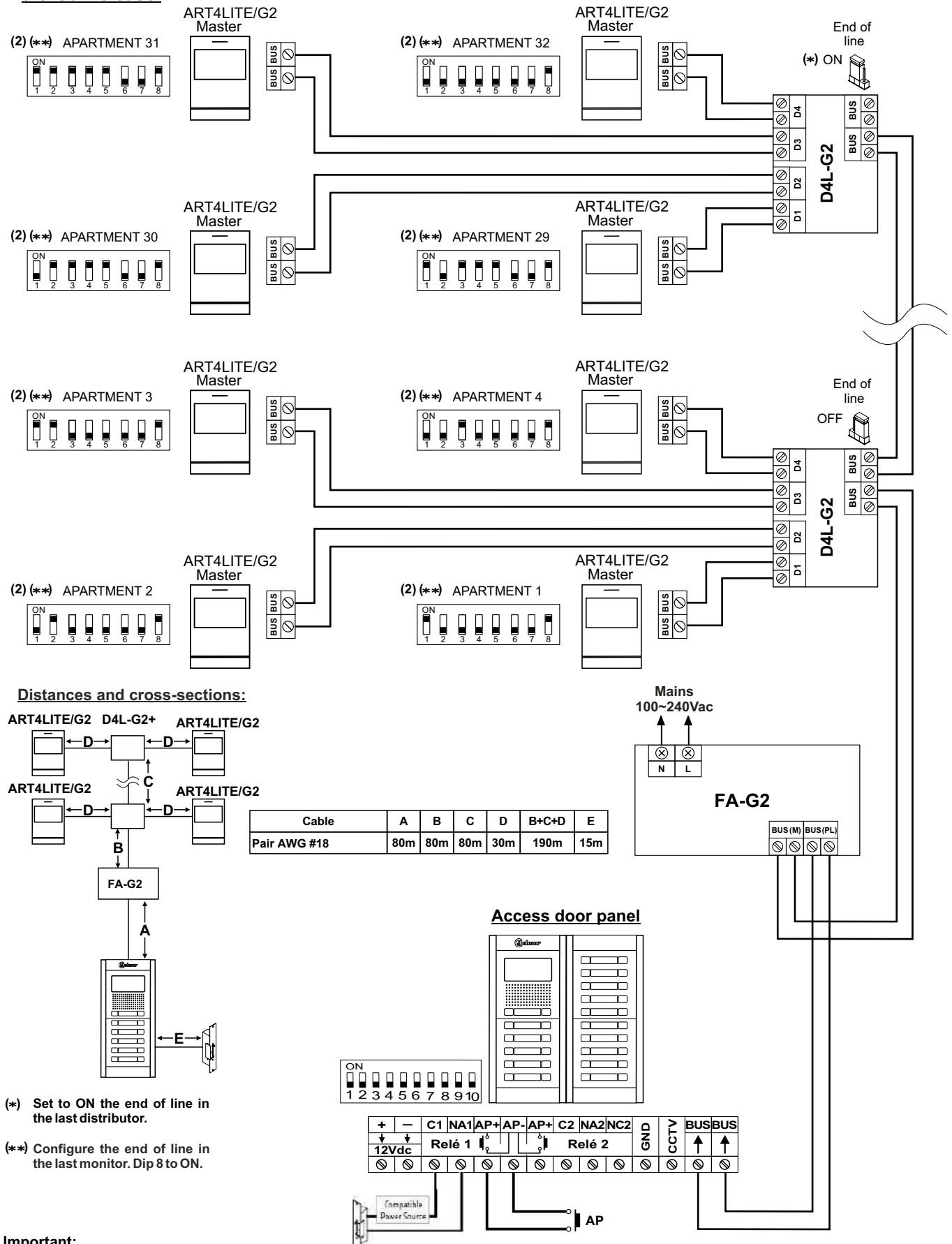

Distances and cross-sections:

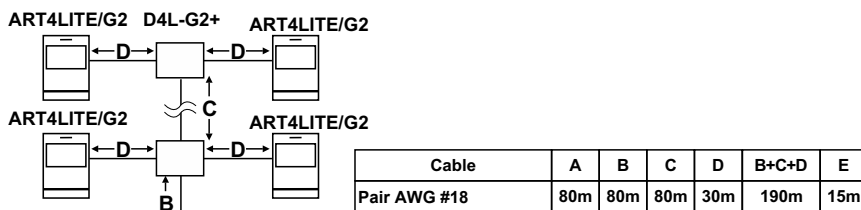

(*) Set to ON the end of line in the last distributor.

(**) Configure the end of line in the last monitor. Dip 8 to ON.

Important:

(1) N/A

(2) For more information of the ART4LITE/G2 monitor, see the quick guide that is attached with its corresponding product.

NEXA MODULAR G2+ AUDIO AND VIDEO DOOR ENTRY SYSTEM - BUILDING 38

WIRING DIAGRAMS

Mixed installation: Up to 32 elements (ART4LITE/G2 monitors & ART1/G2 audio terminals), 8 D4L-G2+ distributors.

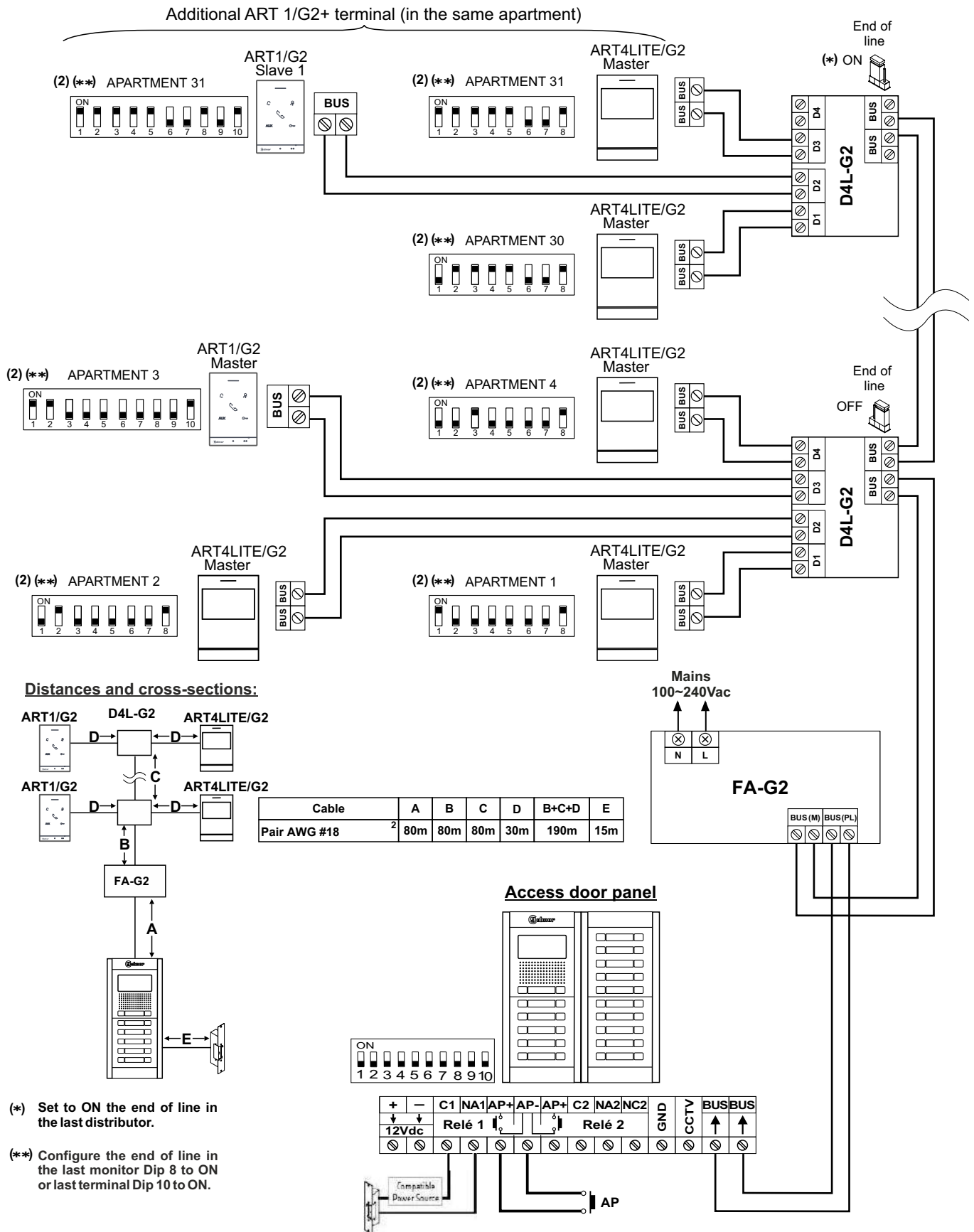

Important:

(1) N/A

(2) For more information of the ART4LITE/G2, & ART1/G2, see the quick guide that is attached with its corresponding product.

NEXA MODULAR G2+ AUDIO AND VIDEO DOOR ENTRY SYSTEM - BUILDING 39

WIRING DIAGRAMS

Video door entry system with 32 ART7LITE/G2 monitors, 8 D4L-G2+ distributors

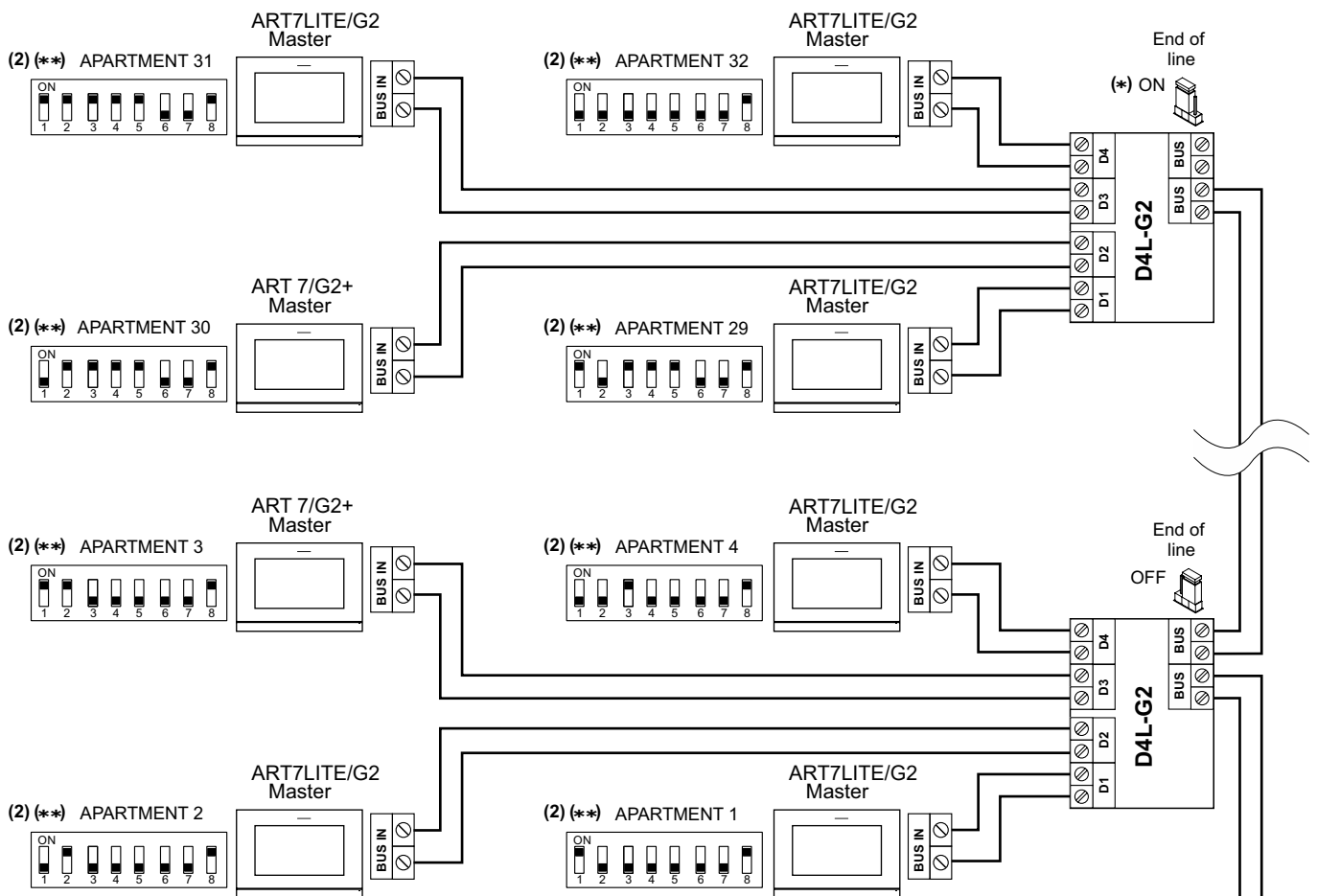

Distances and cross-sections:

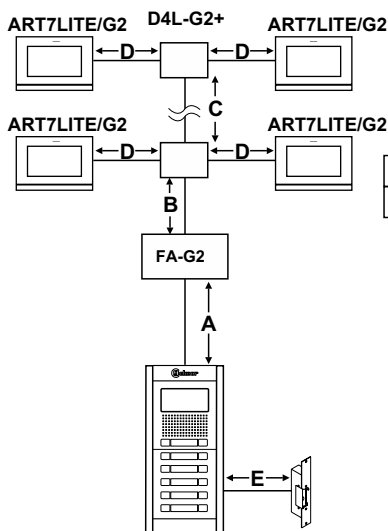

Cable	A	B	C	D	B+C+D	E
Pair AWG #18	80m	80m	80m	30m	190m	15m

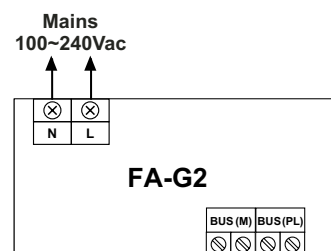

Access door panel

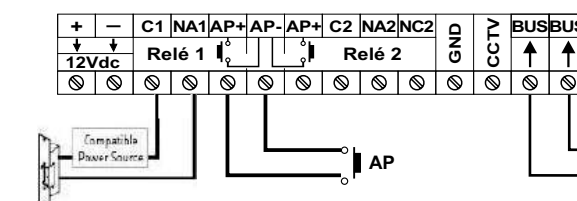
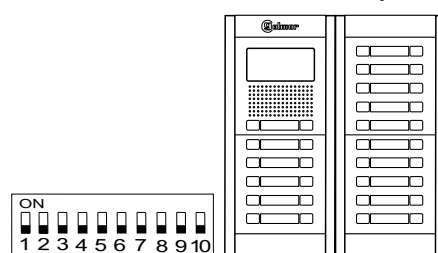

(*) Set to ON the end of line in the last distributor.

(**) Configure the end of line in the last monitor. Dip 8 to ON.

Important:

(1)

(2) For more information of the ART7LITE/G2 monitor, see the quick guide that is attached with its corresponding product.

NEXA MODULAR G2+ AUDIO AND VIDEO DOOR ENTRY SYSTEM - BUILDING 40

WIRING DIAGRAMS

Video door entry system with 32 ART7 LITE/G2+ monitors and 16 D2L-G2 distributors

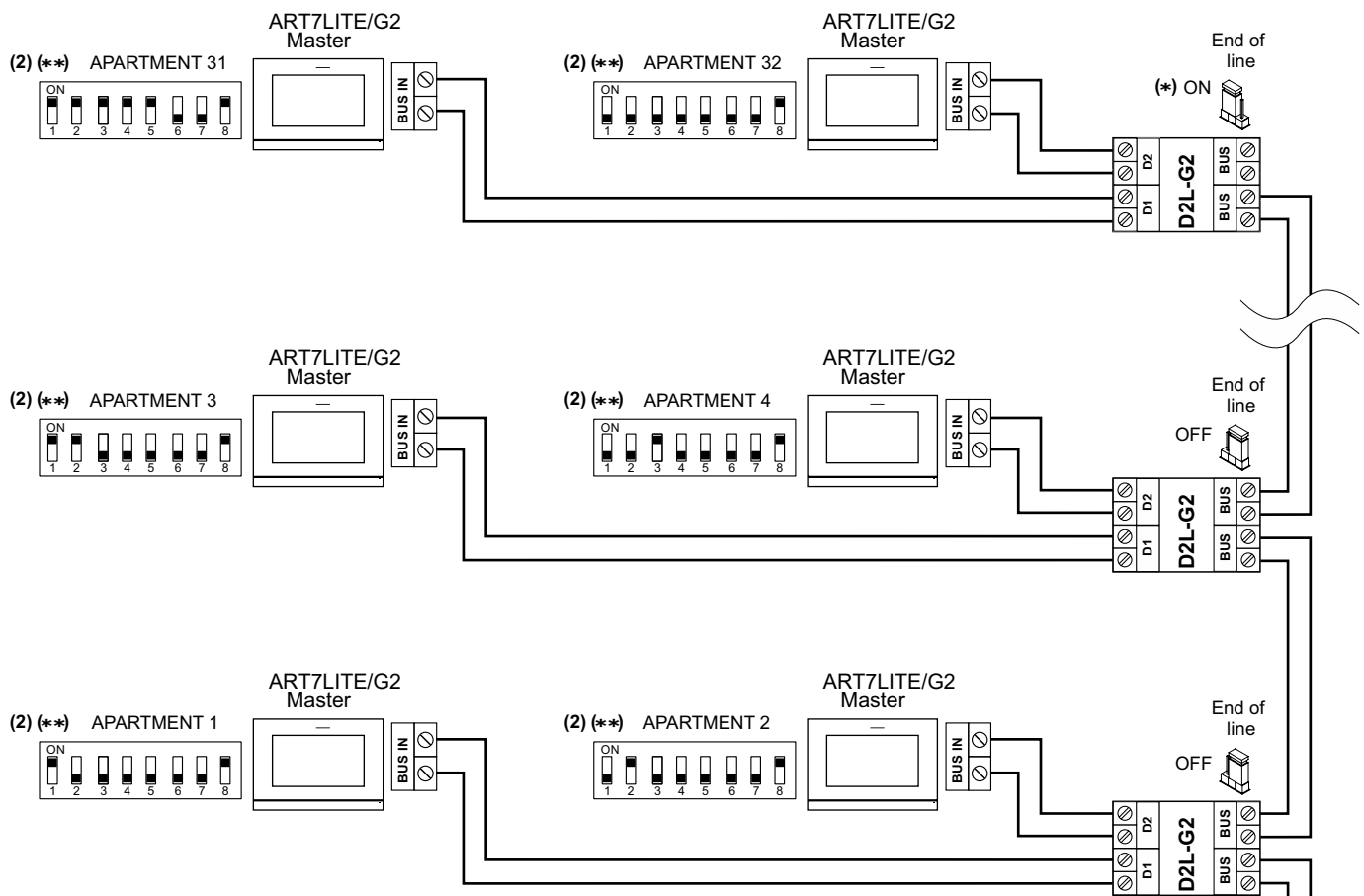

Distances and cross-sections:

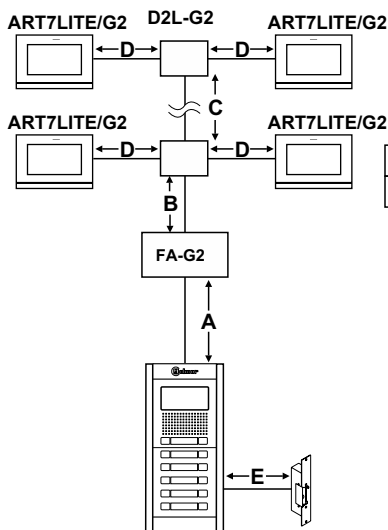

Cable	A	B	C	D	B+C+D	E
Pair AWG #18	80m	80m	80m	30m	130m	15m

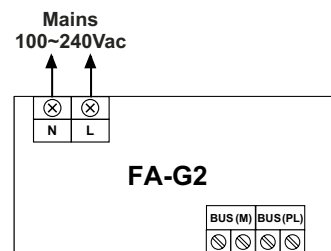

Access door panel

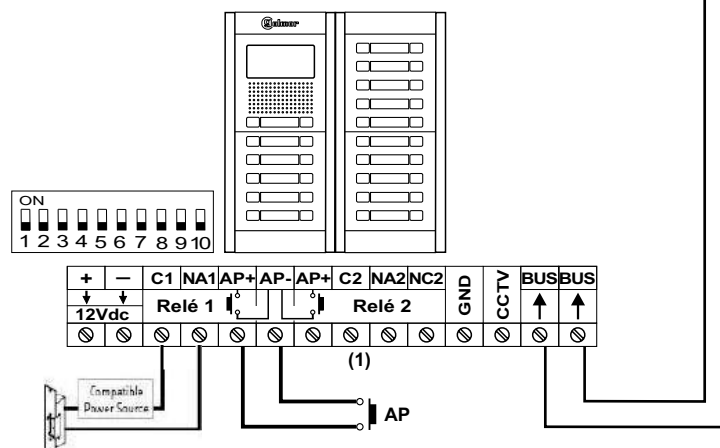

(*) Set to ON the end of line in the last distributor.

(**) Configure the end of line in the last monitor. Dip 8 to ON.

Important:

(1)

(2) For more information of the ART7LITE/G2 monitor, see the quick guide that is attached with its corresponding product.

NEXA MODULAR G2+ AUDIO AND VIDEO DOOR ENTRY SYSTEM - BUILDING 41

WIRING DIAGRAMS

Mixed installation: Up to 32 elements (ART7W/G2 or ART7LITE/G2 monitors, ART1/G2 audio terminals), 8 D4L-G2+ distributors

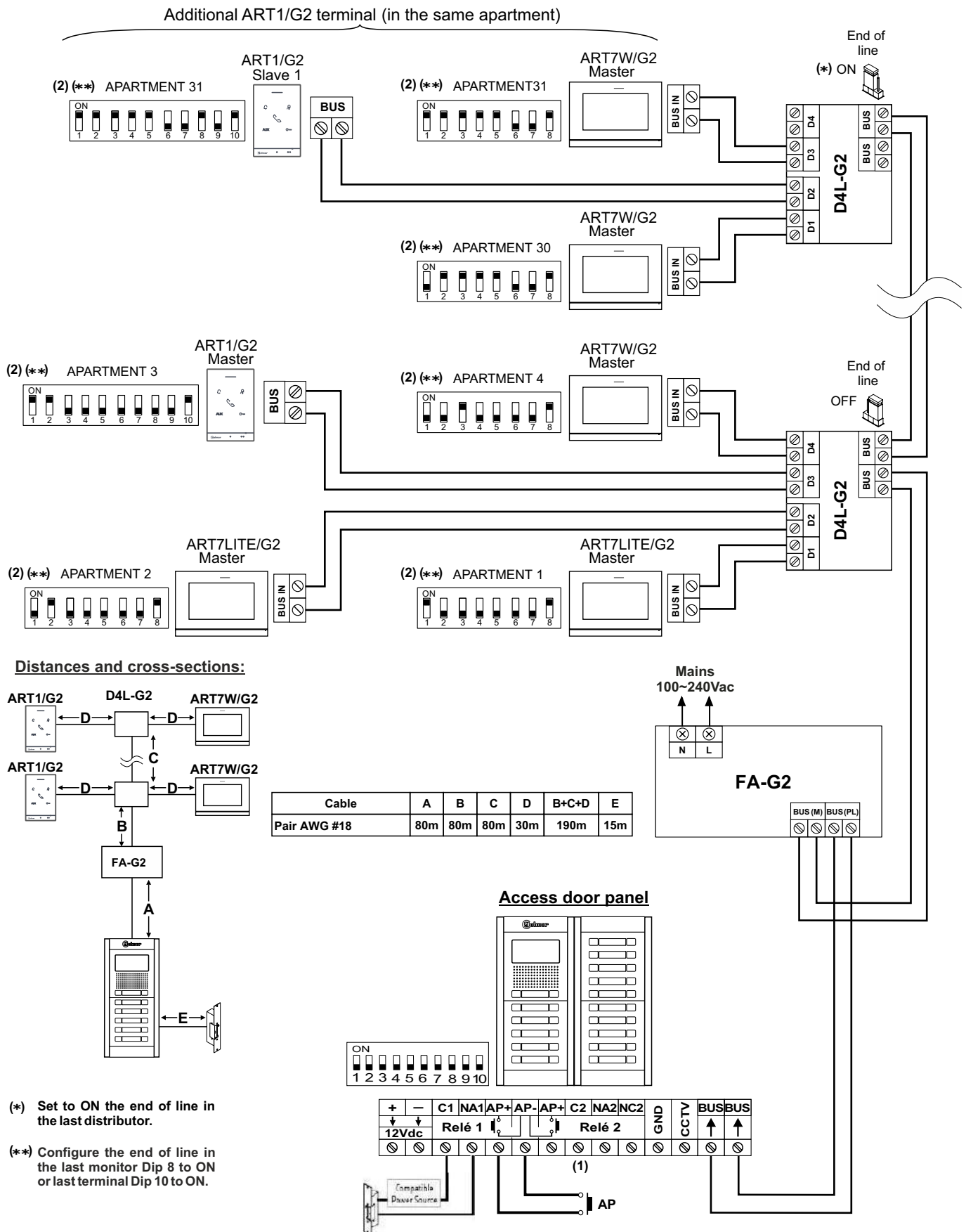

(*) Set to ON the end of line in the last distributor.

(**) Configure the end of line in the last monitor Dip 8 to ON or last terminal Dip 10 to ON.

Important:

(1) N/A

(2) For more information of the ART7LITE/G2 monitor, see the quick guide that is attached with its corresponding product.

NEXA MODULAR G2+ AUDIO AND VIDEO DOOR ENTRY SYSTEM - BUILDING 42

WIRING DIAGRAMS

Video door entry system with 32 ART 7W/G2+ monitors, 8 D4L-G2+ distributors and Golmar d.c lock release.

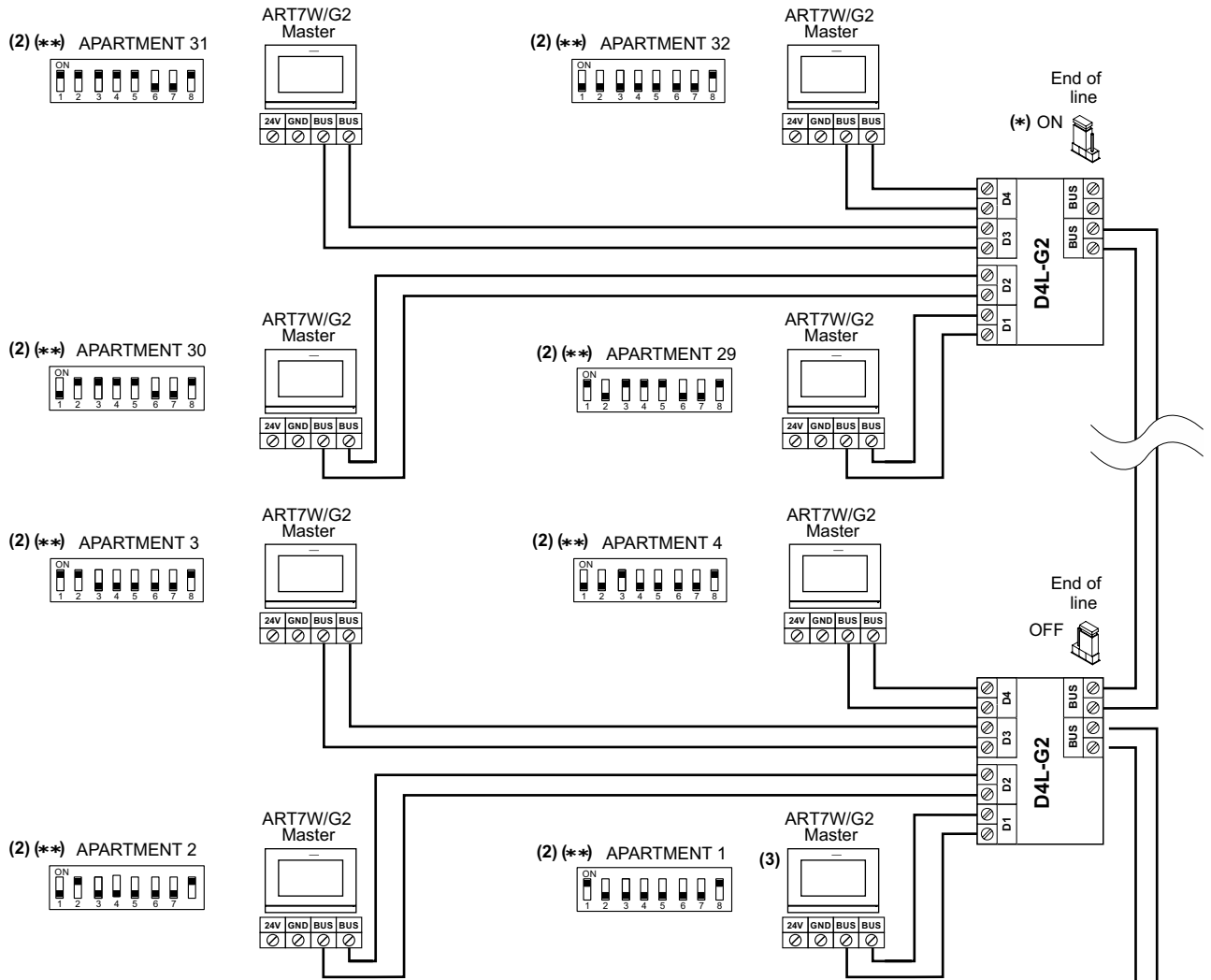

Distances and cross-sections:

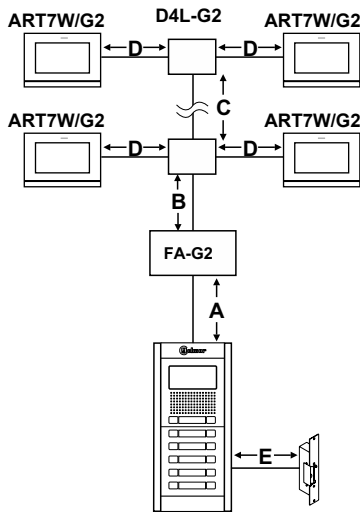

Cable	A	B	C	D	B+C+D	E
Pair AWG #18	80m	80m	80m	30m	190m	15m

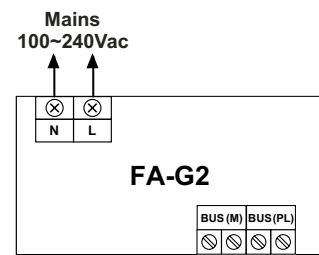

Access door panel

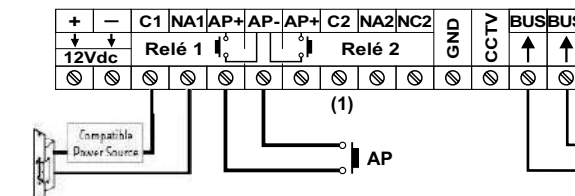
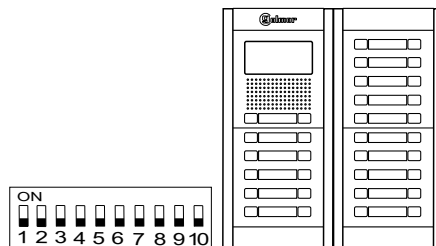

(*) Set to ON the end of line in the last distributor.

(**) Configure the end of line in the last monitor. Dip 8 to ON.

Important:

(1) N/A

(2) For more information of the ART 7W G2+ monitor, see the quick guide that is attached with its corresponding product.

NEXA MODULAR G2+ AUDIO AND VIDEO DOOR ENTRY SYSTEM - BUILDING 43

WIRING DIAGRAMS

Video door entry system with 32 ART7W/G2 monitors and 16 D2L-G2 distributors

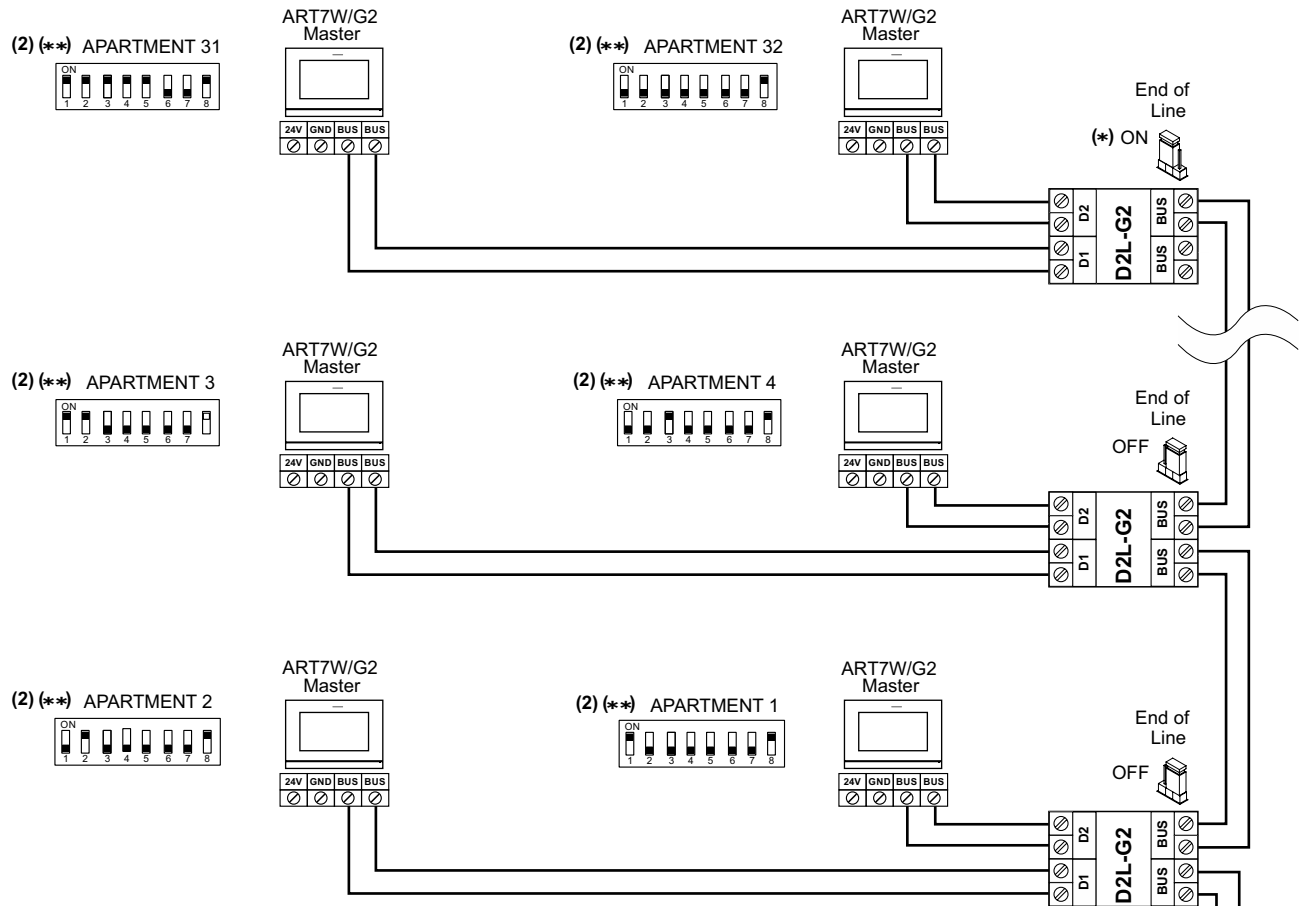

Distances and cross-sections:

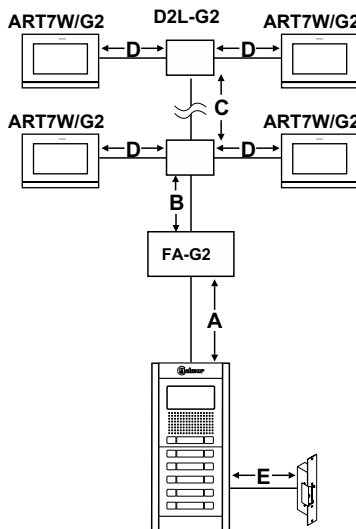

Cable	A	B	C	D	B+C+D	E
Pair AWG #18	80m	80m	80m	30m	190m	15m

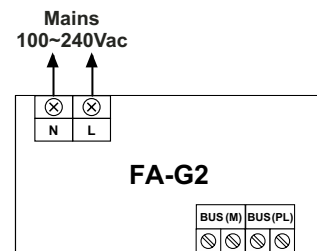

Access door panel

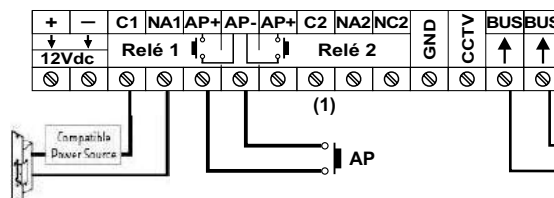
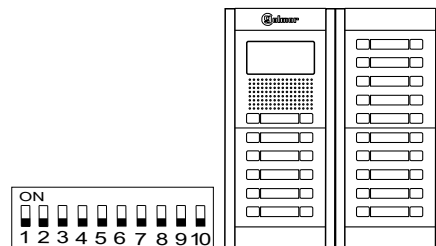

(*) Set to ON the end of line in the last distributor.

(**) Configure the end of line in the last monitor. Dip 8 to ON.

Important:

(1) N/A

(2) For more information of the ART7W/G2 monitor, see the quick guide that is attached with its corresponding product.

NEXA MODULAR G2+ AUDIO AND VIDEO DOOR ENTRY SYSTEM - BUILDING 44

WIRING DIAGRAMS

Mixed installation: Up to 32 elements (ART 7LITE/G2 monitors & ART1/G2 audio terminals), & 8 D4L-G2+ distributors

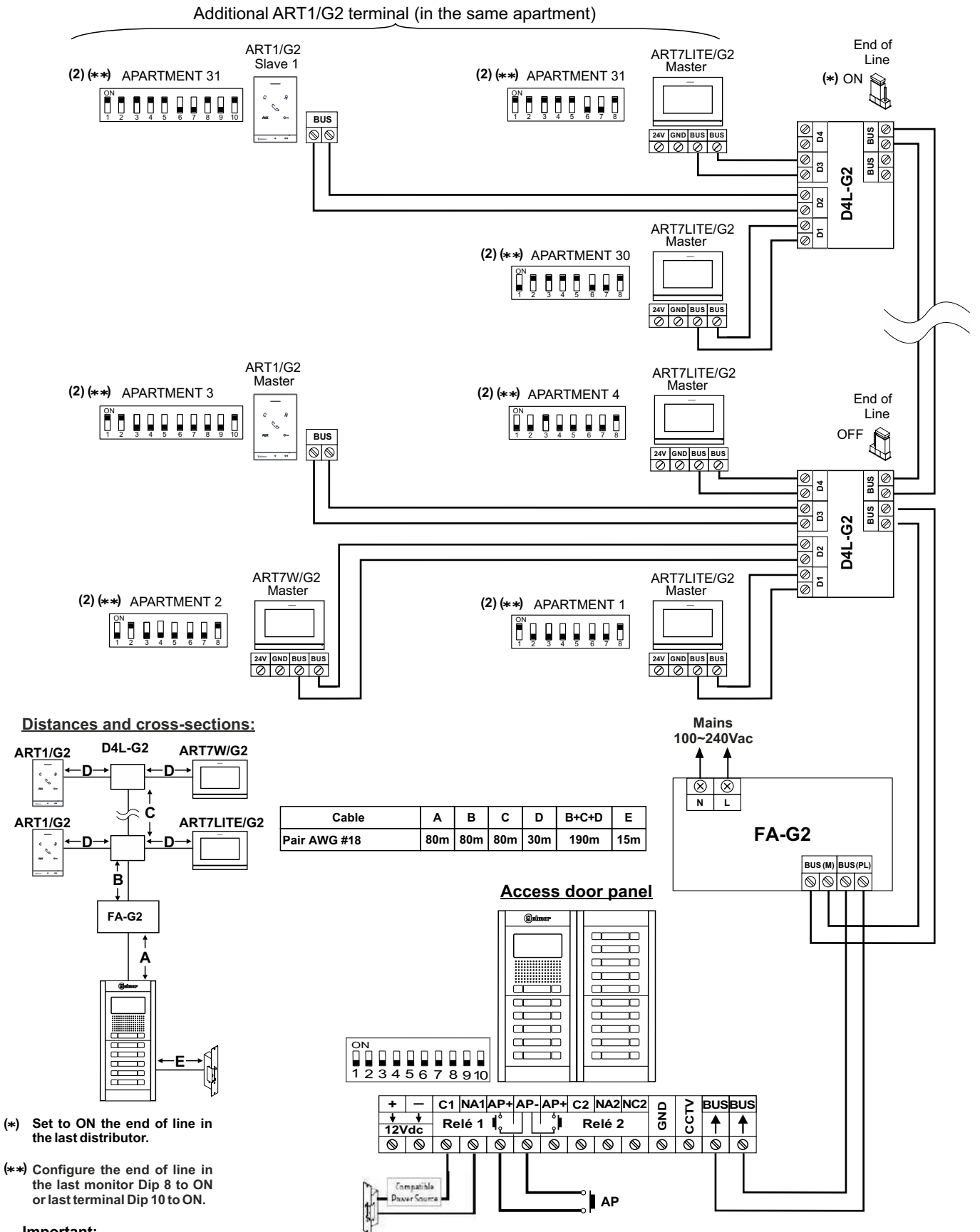

(*) Set to ON the end of line in the last distributor.

(**) Configure the end of line in the last monitor Dip 8 to ON or last terminal Dip 10 to ON.

Important:

(1) N/A

(2) For more information of the ART 7W G2+ monitor, see the quick guide that is attached with its corresponding product.

NEXA MODULAR G2+ AUDIO AND VIDEO DOOR ENTRY SYSTEM - BUILDING 45

WIRING DIAGRAMS

Video door entry system with 12 monitors ART7W/G2/ART 7 LITE/G2+ monitors IN-OUT without distributors

IMPORTANT: Up to 12 monitors in IN-OUT without distributors, per installation (building).

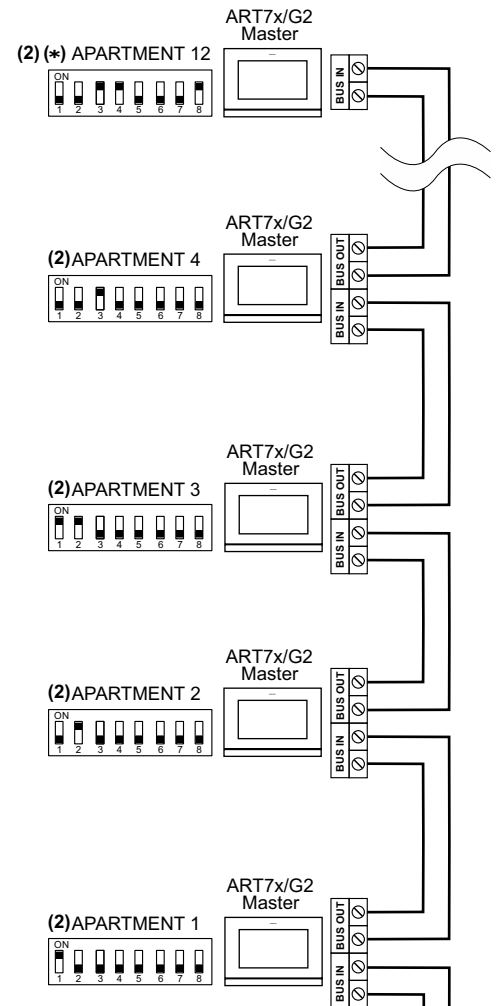

Distances and cross-sections:

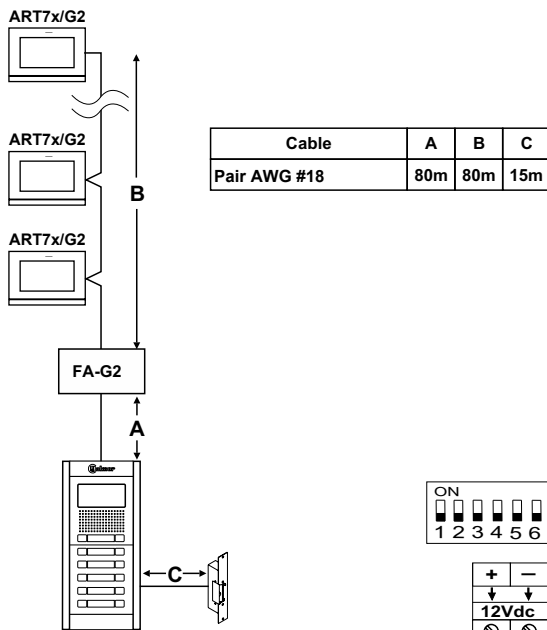

(*) Configure the end of line in the last monitor. Dip 8 to ON.

Important:

(1) N/A

(2) For more information of the ART7W/G2 or ART7LITE/G2 monitor, see the quick guide that is attached with its corresponding product.

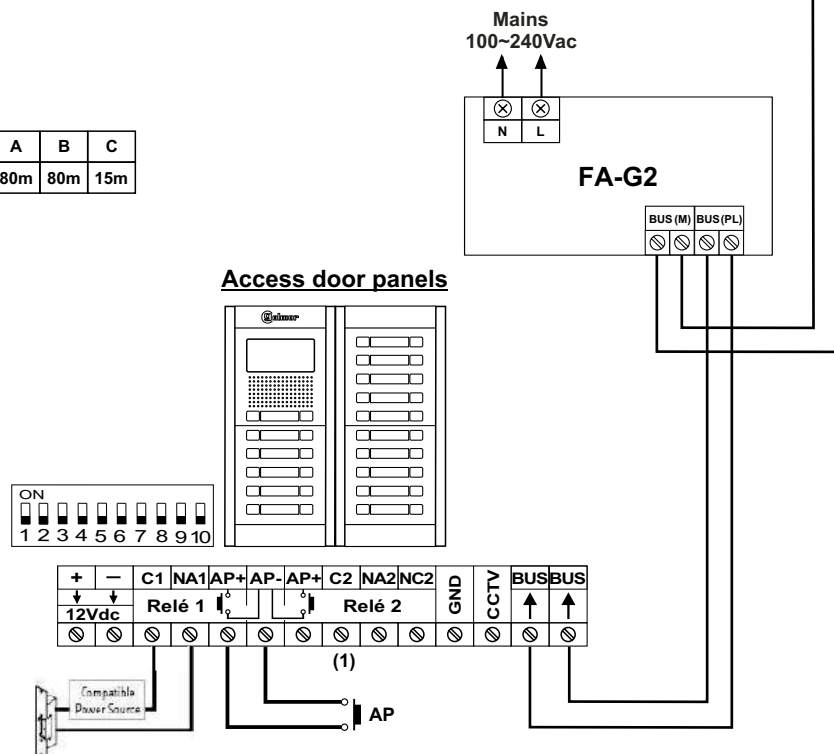

WIRING DIAGRAMS

Video door entry system with 32 ART7W/G2 or ART7LITE/G2 monitors, 2 risers with D2L-G2+ distributors

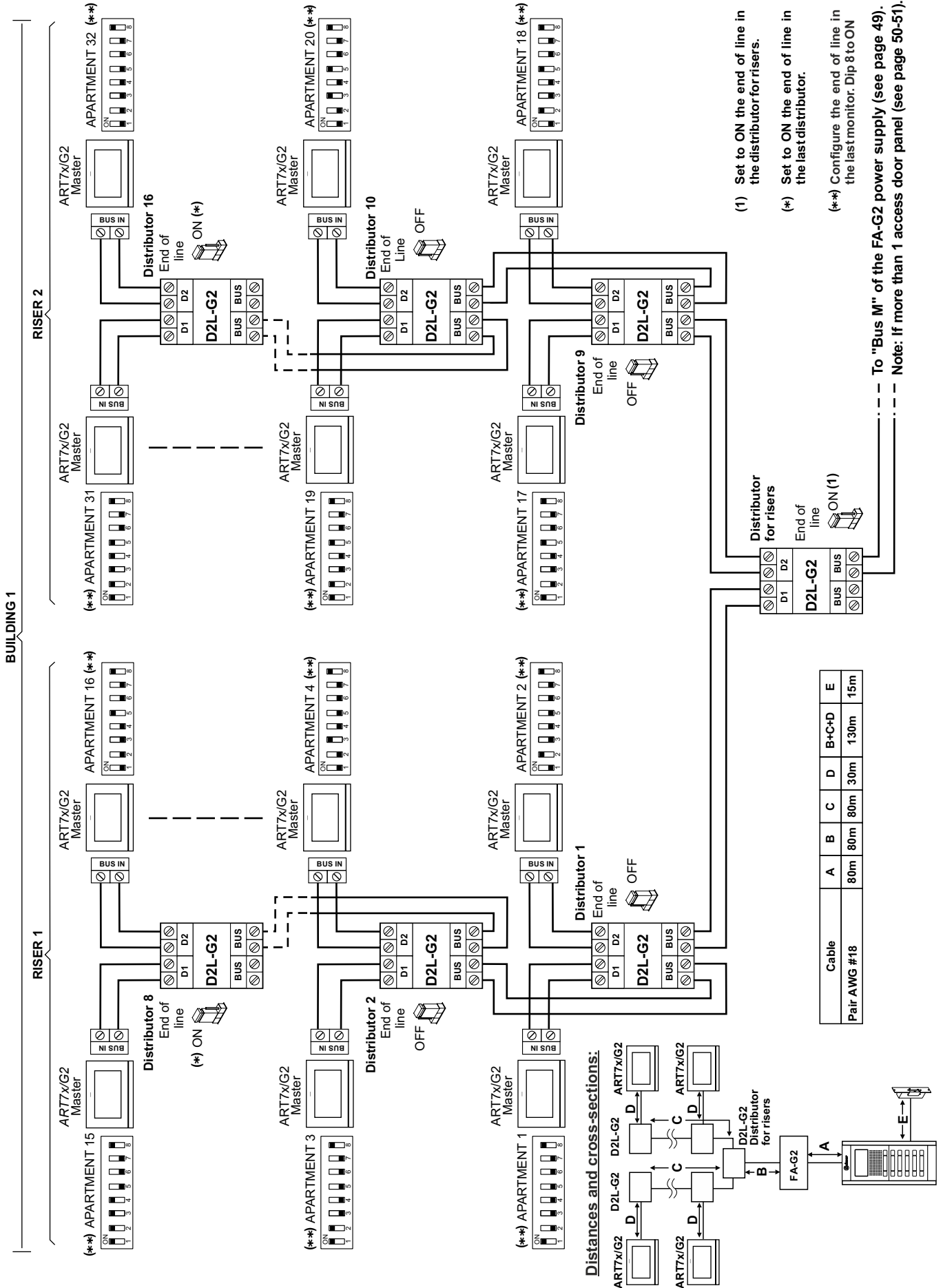

NEXA MODULAR G2+ AUDIO AND VIDEO DOOR ENTRY SYSTEM - BUILDING 47

WIRING DIAGRAMS

Video door entry system with 32 ART 7/G2+ or ART 7 LITE/G2+ monitors, 4 risers with D4L-G2+ distributors and Golmar d.c lock release.

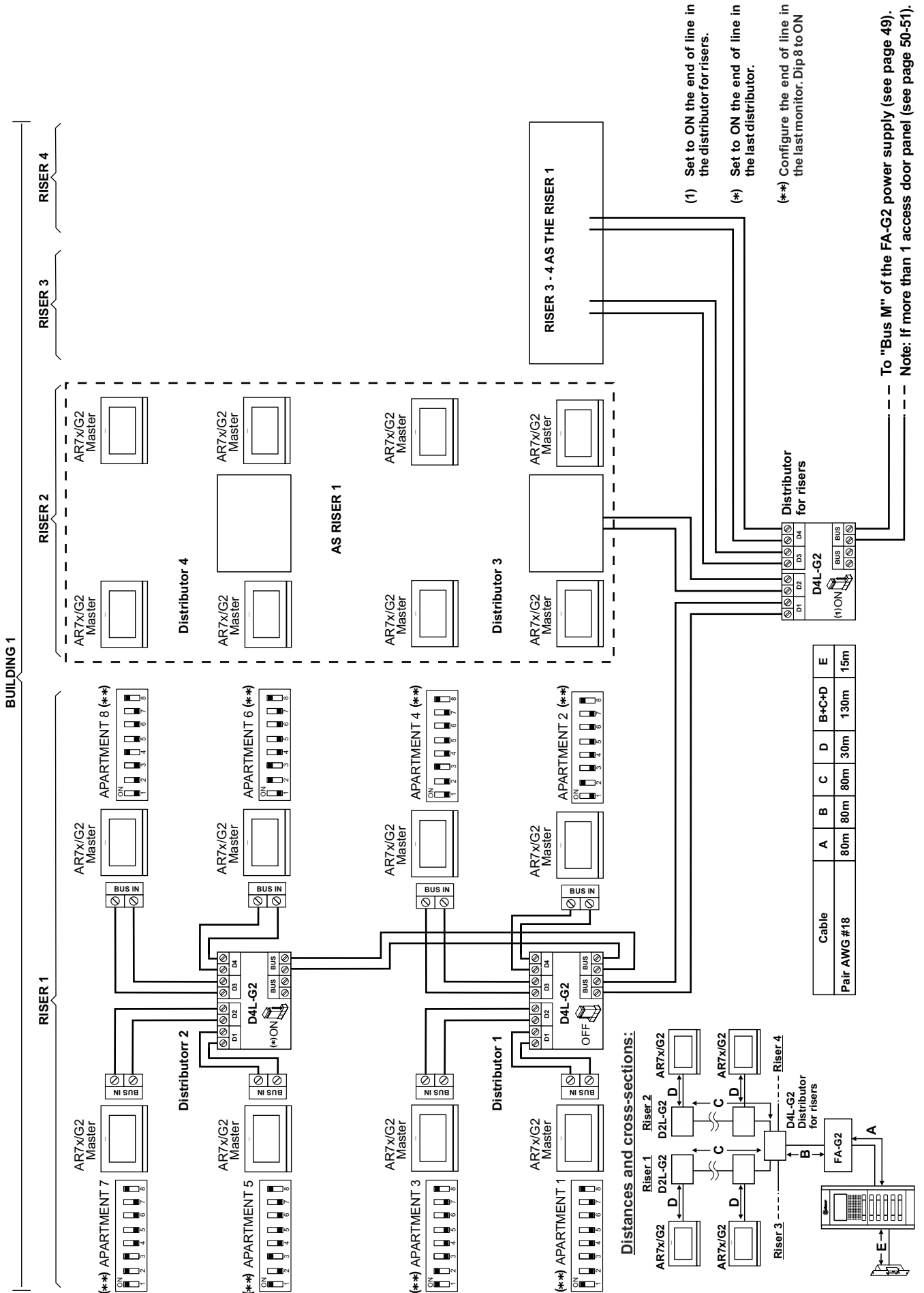

WIRING DIAGRAMS

Video door entry system with 32 ART7W/G2 or ART7LITE/G2 monitors in IN-OUT, 4 risers without distributors

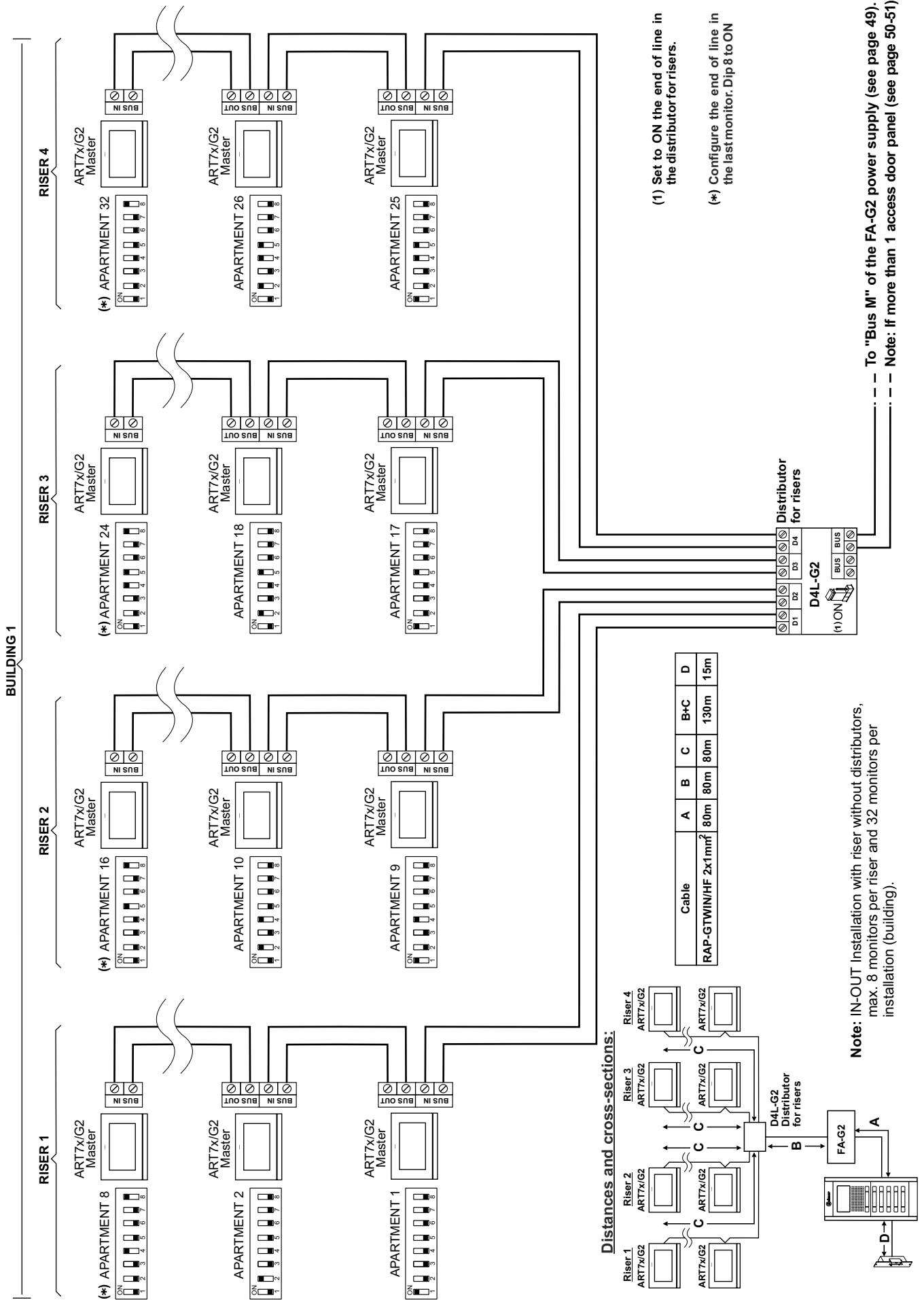

NEXA MODULAR G2+ AUDIO AND VIDEO DOOR ENTRY SYSTEM - BUILDING 49

WIRING DIAGRAMS

1 Building of video door entry system with risers (from 2 to 4) and 1 door panel with Golmar d.c lock release.

1 Building of audio door entry system with risers (from 1 to 8) and 1 door panel with Golmar d.c lock release.

Video door entry system: To distributor for risers of the building (see pages 46 to 48)

Audio door entry system: To electrical junction box for risers of the building (see page 35)

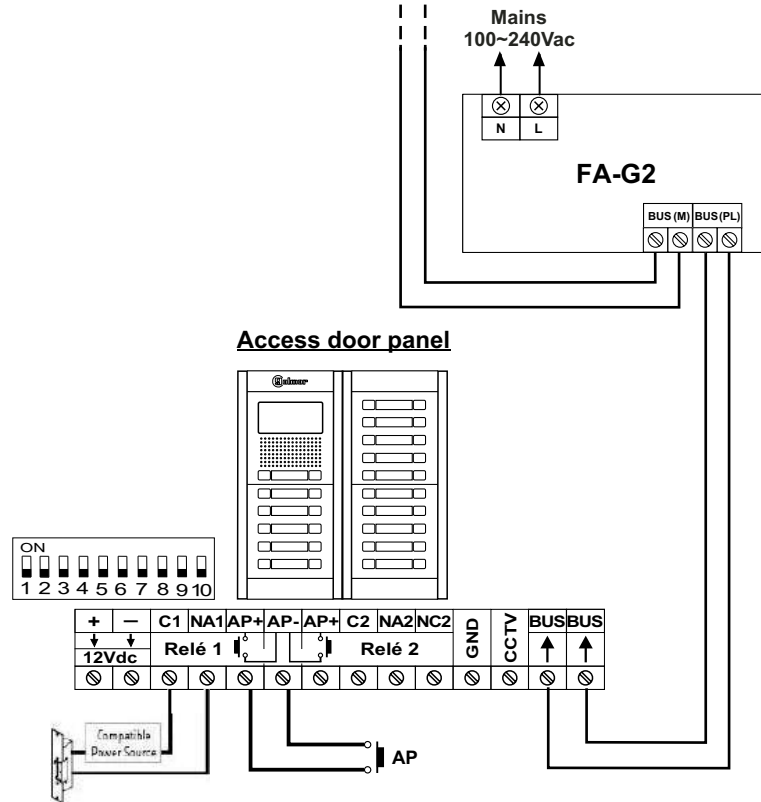

NEXA MODULAR G2+ AUDIO AND VIDEO DOOR ENTRY SYSTEM - BUILDING 50

WIRING DIAGRAMS

Audio and Video door entry system with 2 access door panels, DPM-G2 door panels distributor

Video door entry system: To the distributors (building floors), see pages 36 to 45.
 To the risers distributor of the building, see pages 46 to 48

Audio door entry system: To electrical junction box for Bus connections ART1/G2 terminals of the building (see page 34).
 To electrical junction box for risers of the building (see page 35).

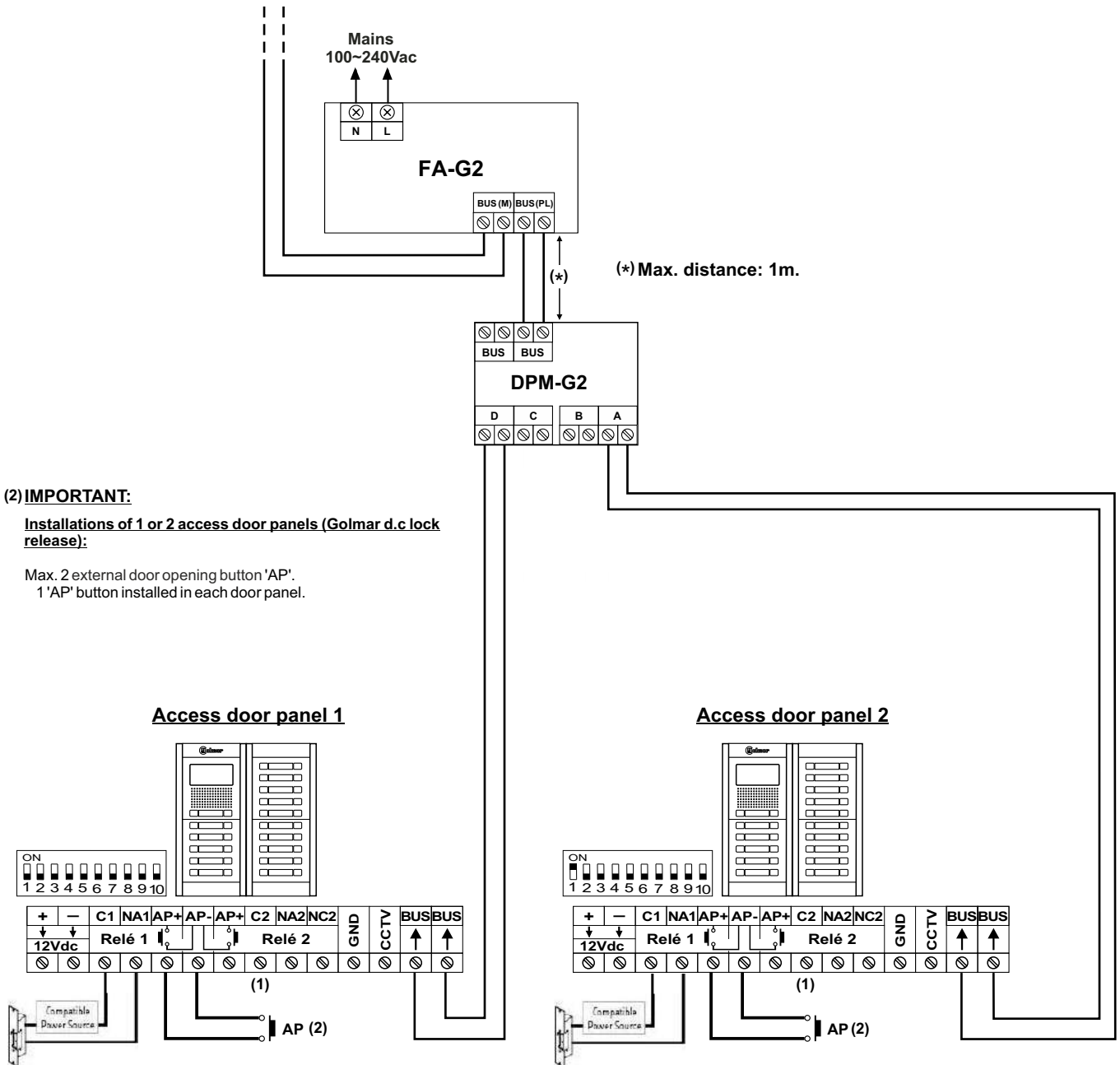

NEXA MODULAR G2+ AUDIO AND VIDEO DOOR ENTRY SYSTEM - BUILDING 51

WIRING DIAGRAMS

Audio and Video door entry system with 4 access door panels, DPM-G2 door panels distributor

Video door entry system: To the distributors (building floors), see pages 36 to 45.

To the risers distributor of the building, see pages 46 to 48

Audio door entry system: To electrical junction box for Bus connections ART 1/G2+ terminals of the building (see page 34).

To electrical junction box for risers of the building (see page 35).

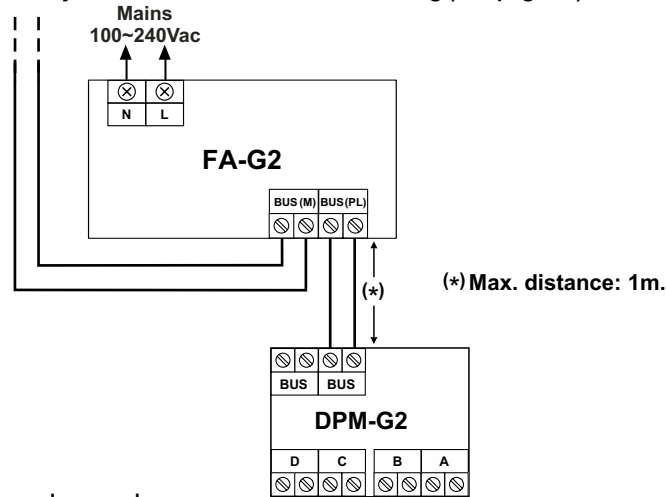

(1) IMPORTANT:

Installations of more than 2 access door panels

Max. 1 external door opening button 'AP'.

1 'AP' button installed **in only one** of the door panels of the installation.

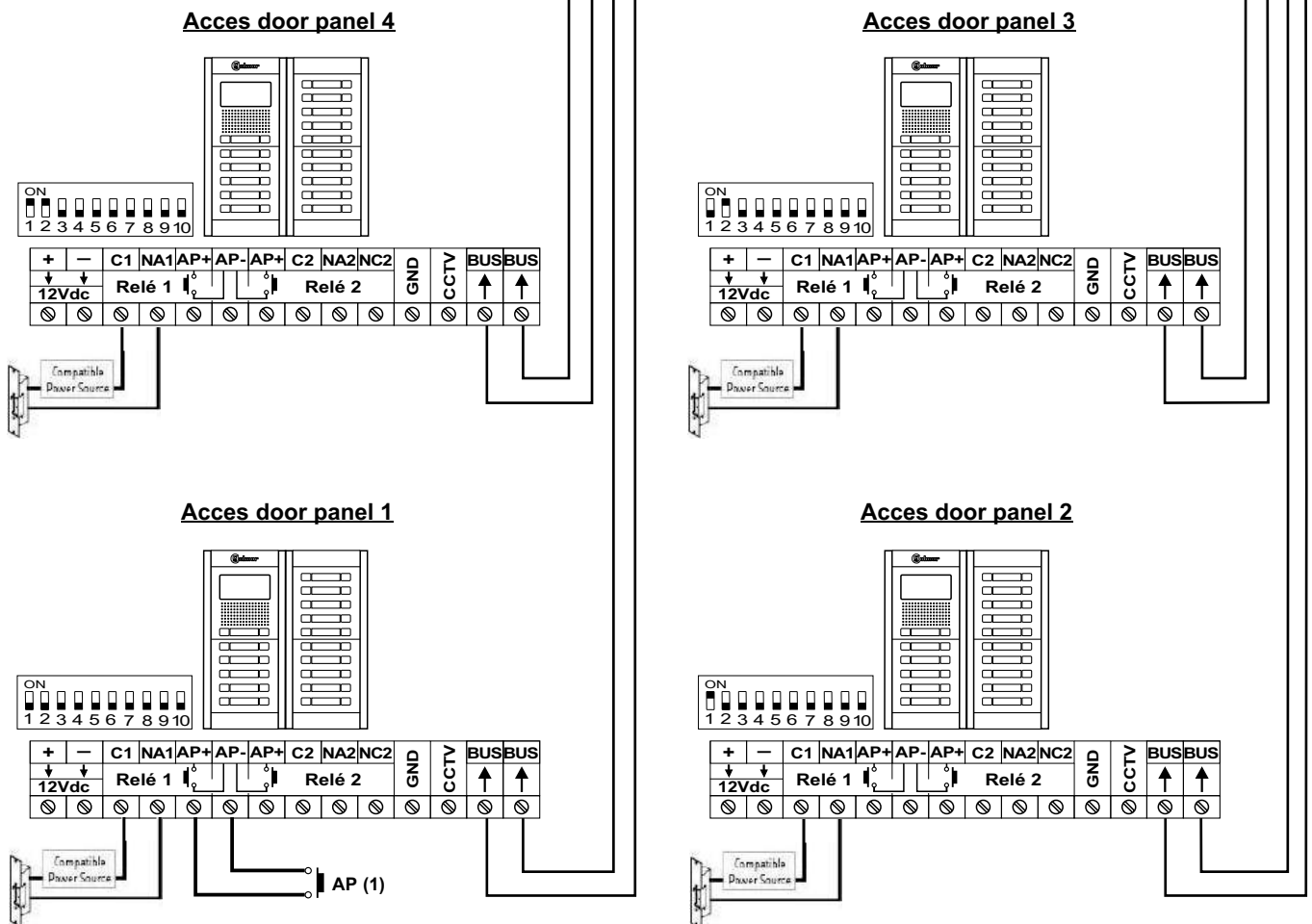

—

NEXA MODULAR G2+ AUDIO AND VIDEO DOOR ENTRY SYSTEM - BUILDING 53

TYPES OF RISER INSTALLATION

Installation with 1 building, 32 monitors, 2 risers and 1 access door panel.

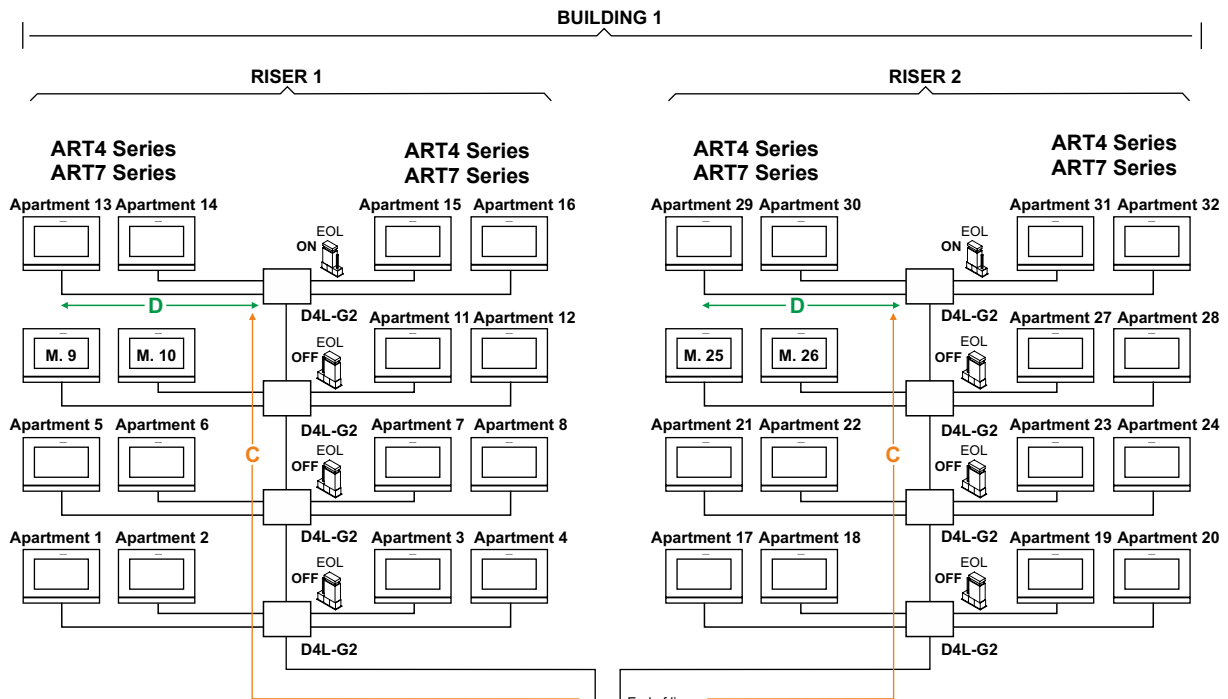

Distances and cross-sections:

Cable	A	B	C	D	B+C+D	E
Pair AWG #18	80m	80m	80m	30m	130m	15m

(*) Max. distance: 1m.

Example of installation type:

- With 32 monitors ART4LITE/G2 monitors.
- With 32 ART7W/G2 / ART7LITE/G2 monitors.

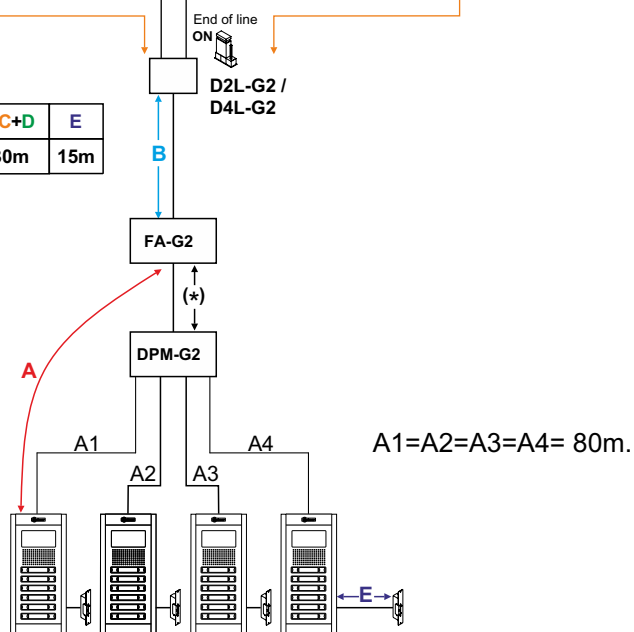

TYPES OF RISER INSTALLATION

Installation with 1 building, 32 monitors, 4 risers and 1 access door panel.

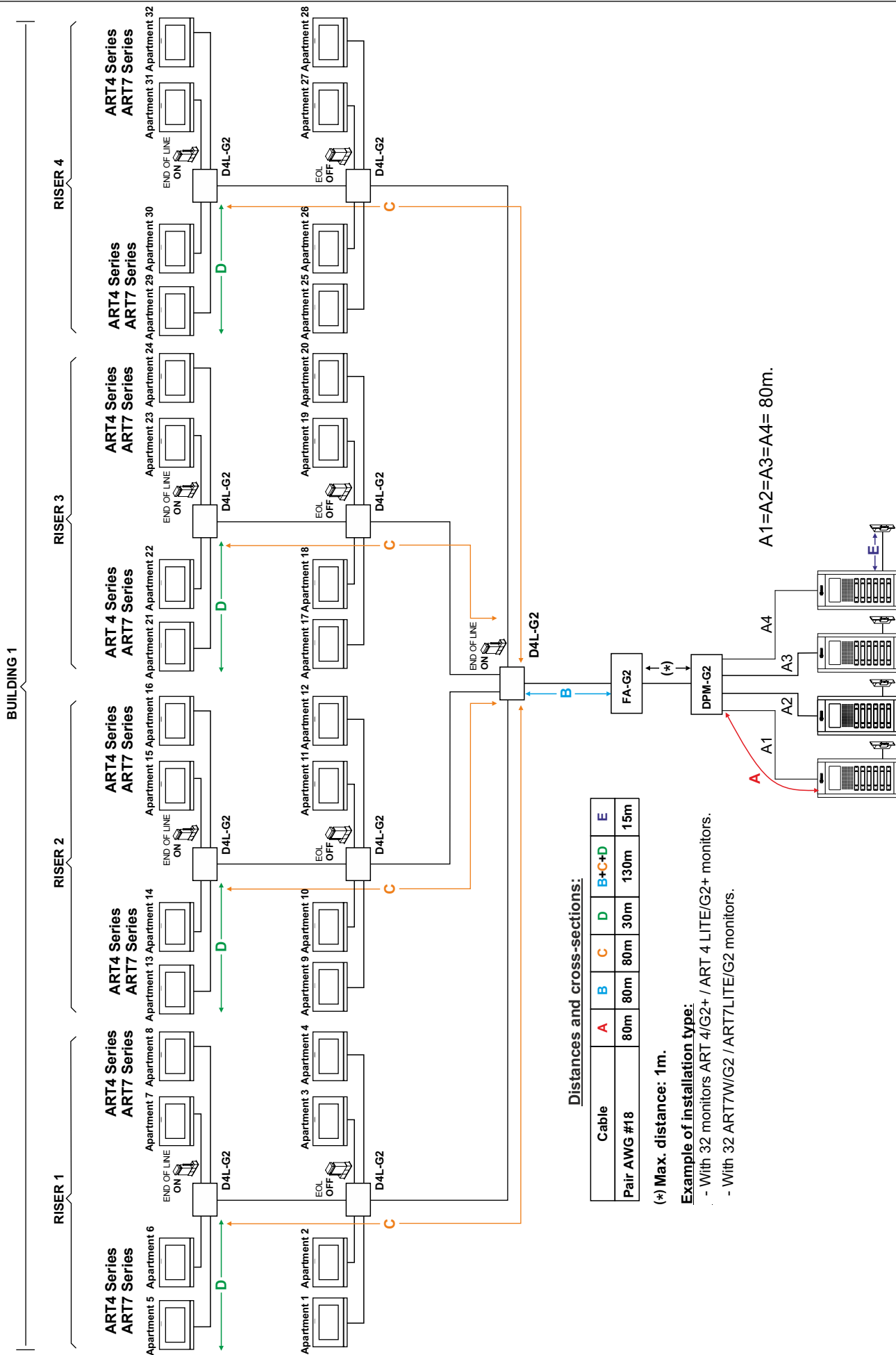

TYPES OF RISER INSTALLATION

Installation with 1 building, 32 monitors, 4 asymmetric risers and 1 access door panel.

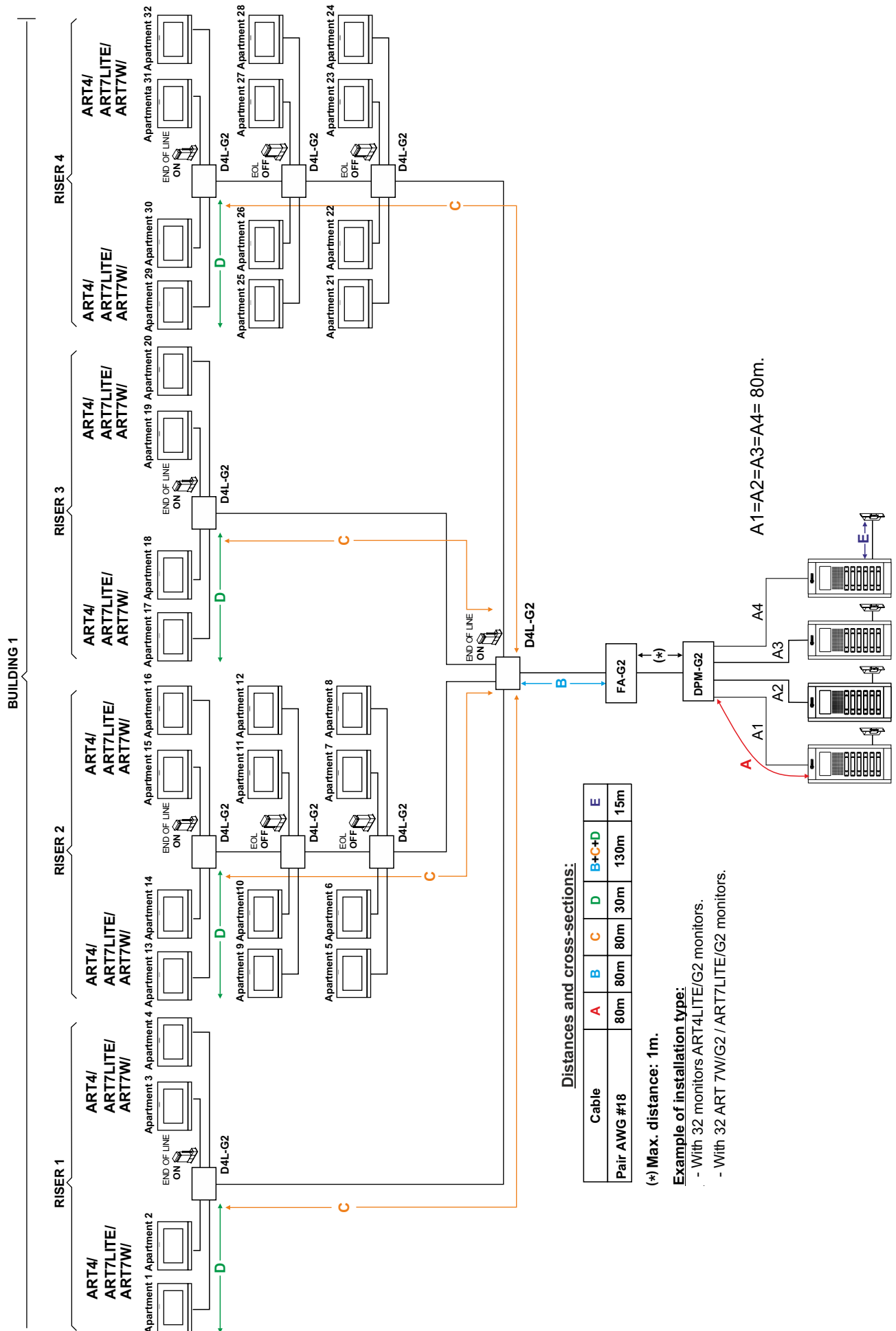

TYPES OF RISER INSTALLATION

Installation with 1 building, 32 monitors, 4 asymmetric risers and 1 access door panel.

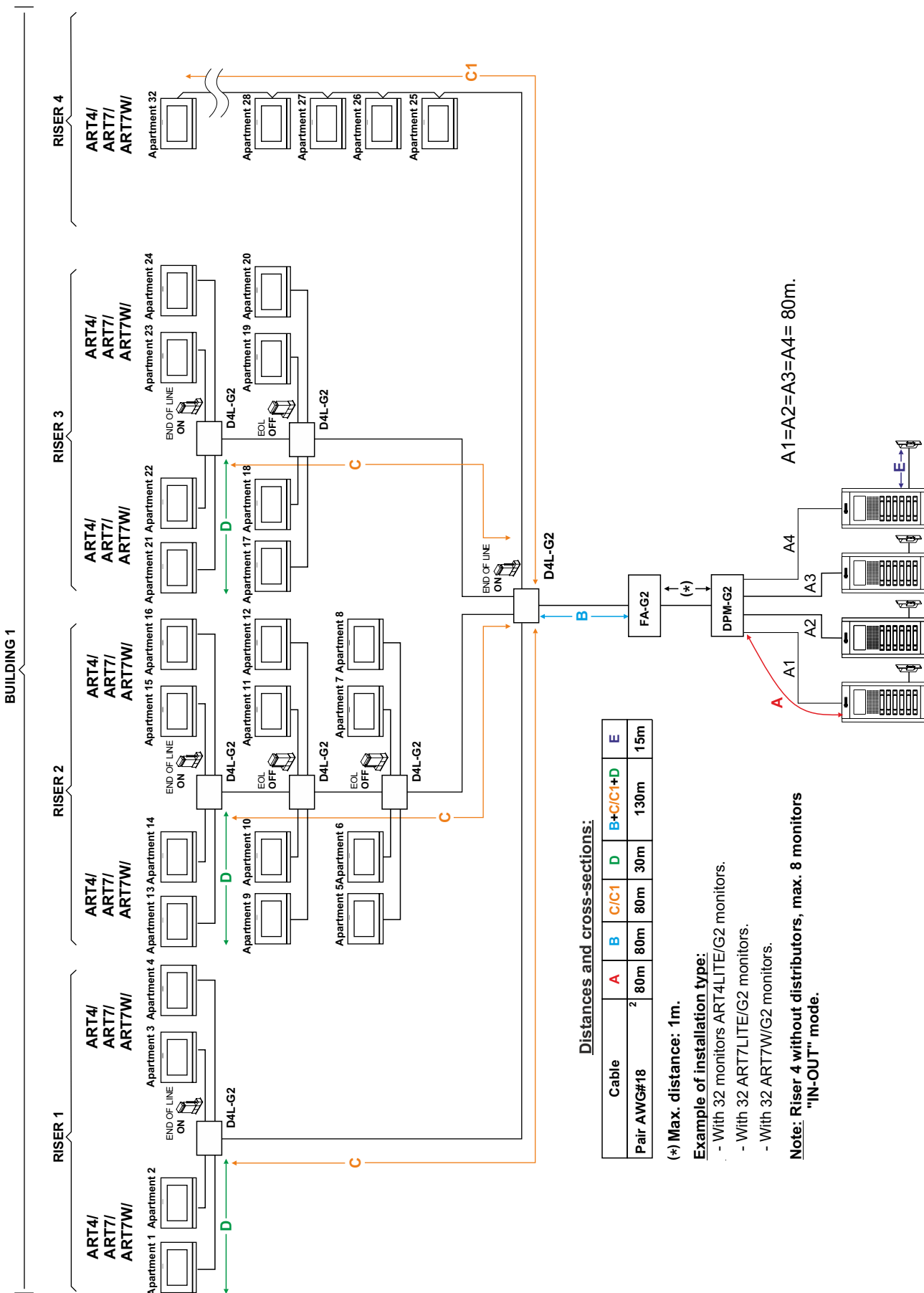

TYPES OF RISER INSTALLATION

Installation with 1 building, 32 monitors, 4 risers without distributors "IN-OUT" mode and 1 access door panel.

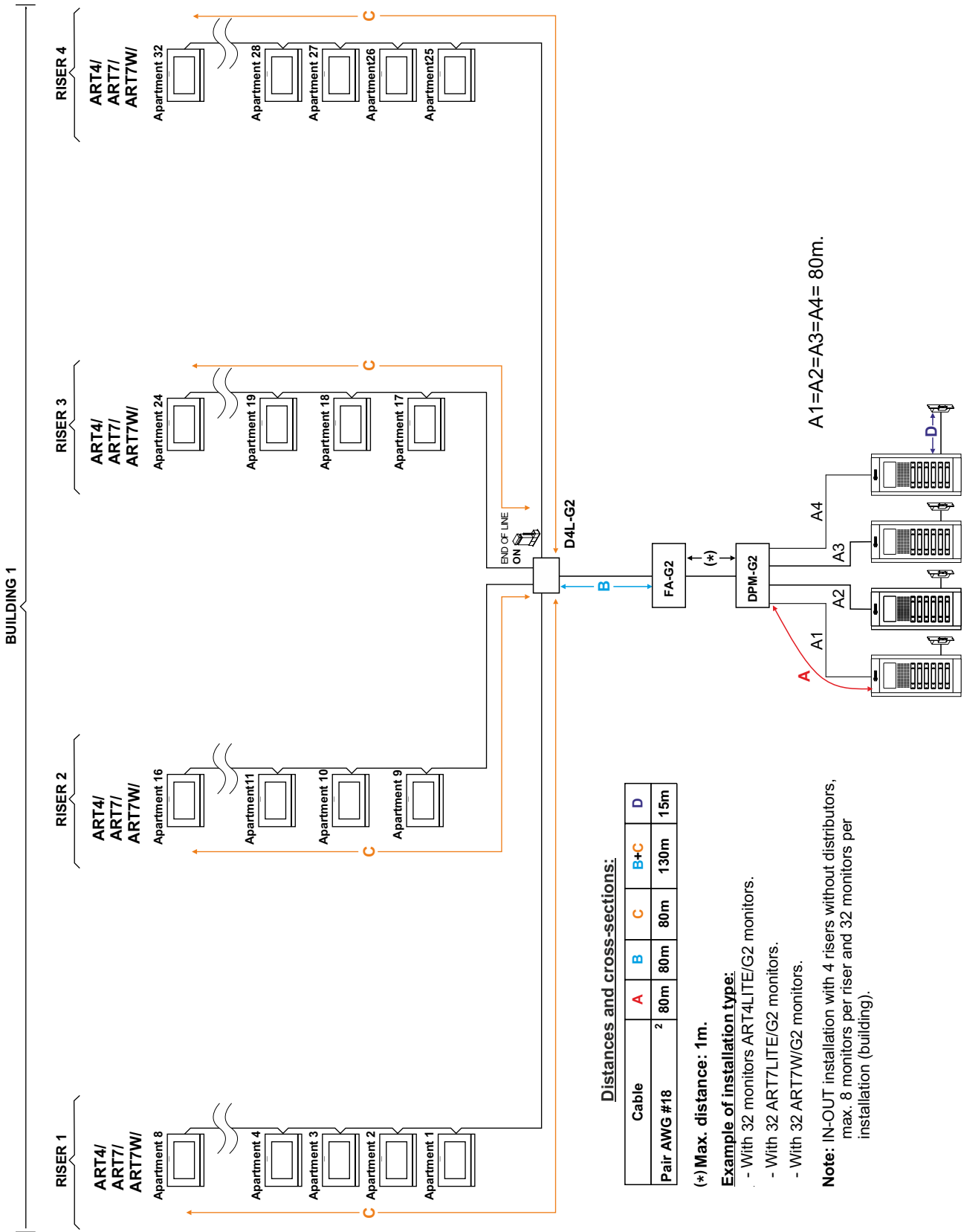

CONNECTION OF AN EXTERNAL CAMERA

It is possible to connect a AHD4-3601x analogue CCTV to the door panel, which can be viewed from the monitor, (see corresponding monitor to activate the external camera CCTV in "Special Codes"). "PSU-121" power supply unit required.

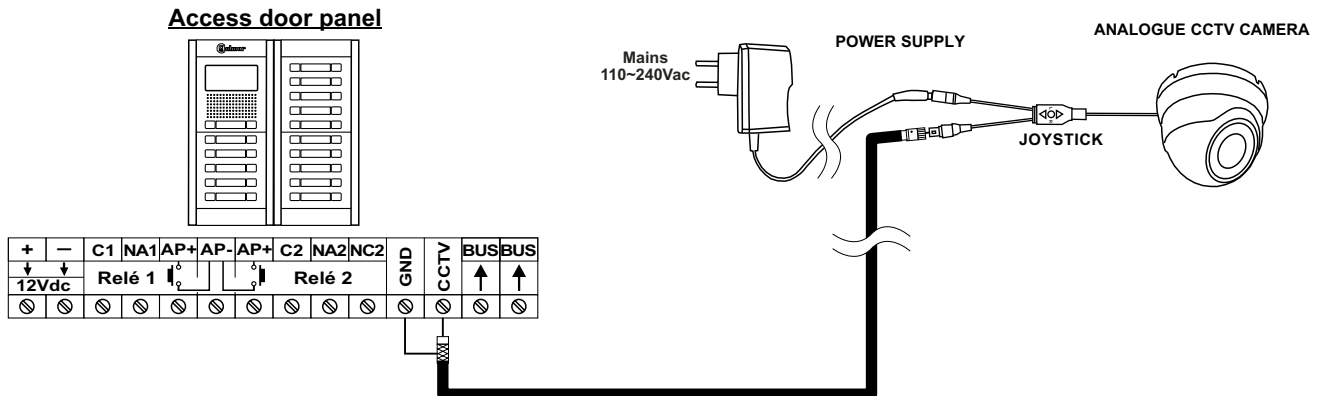

Important: Set the camera with a CVBS analogue signal, as described in the accompanying AHD4-3601x camera manual.

CLEANING THE DOOR PANEL

- Do not use solvents, detergents or cleaning products that contain acids, vinegar or abrasive components.
- Use a soft damp cloth (not wet) that sheds no fibres.
- Always wipe the door panel in the same direction, from top to bottom.
- After cleaning the door panel, remove any moisture with a soft dry cloth that sheds no fibres.

