

# Installation & User Manual

## Obyn Multi - IP Multi-Apartment Intercom

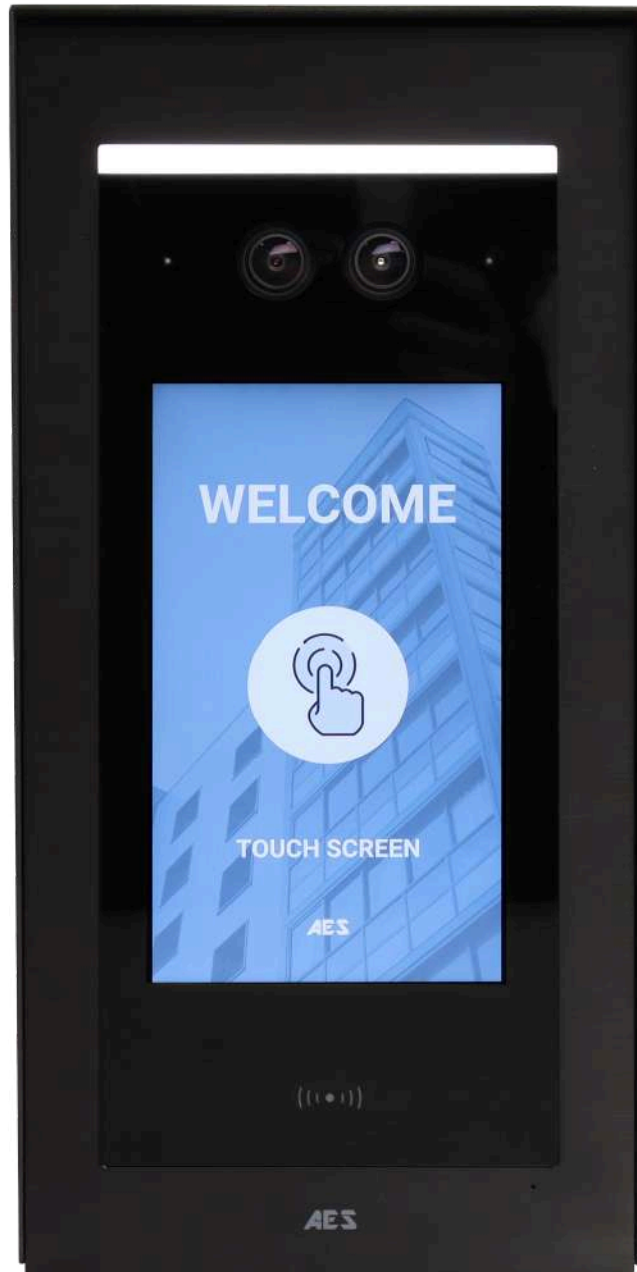

The information in this document may be changed as we always strive to improve the product. Trust that the information provided is accurate at the time of document release.

# Table of Contents

<b>Table of Contents</b>	<b>2</b>
Technical Specifications	5
Packing Contents	6
Product Variations	7
Optional Extra Equipment	8
Installation Information	9
1. Site Survey & Bench Testing	9
2. Installation	9
3. Wiring Diagram	11
4. Relay Connections	12
5. Power	13
a. 12v DC	13
b. 48v POE	13
6. Network Connection	13
a. Ethernet	13
b. 4G	14
Setup	15
1. Account Creation	15
2. Create a site	15
3. Create a block	16
4. Create a panel	16
5. Setup users	17
6. Licences	18
7. Example Setups	19
a. Apartment Buildings	19
b. Gated Community	19
c. Business Park	20
Panel Operation	21
1. Icon Meaning	21
2. Unlock Page	21
a. Keypad Code	22
b. Facial Recognition	22
c. QR Code	22
d. Prox Card	22
3. Call Page	23
4. Contacts Page	24
5. Settings Page	24
a. Device Information	25
b. Access	25
c. System	26
d. Password	26

e. About	27
f. Contact	27
Management Portal Operation	28
1. Company Dashboard	28
a. Sites	28
b. Company Admin	28
c. Purchase Record	29
2. Site Dashboard	29
a. Blocks	29
b. Panels	29
c. Site Users	31
d. Operation Log	33
e. Panel Log	33
f. Site Licences	34
g. Payments	35
h. Notice	35
App Operation	37
1. Add Intercom to Device	37
2. Basic Setup & Operation	37
a. Answer Call	37
b. Two-Way Speech	38
c. Activate Relays/Locks	39
d. View Cameras	39
3. Devices (Home Page)	40
a. Relay Activation	40
b. Add Device	40
c. Apartment Settings	40
d. Activity	40
e. Settings	40
f. Camera Preview	41
4. Apartment Settings	41
a. Apartment Name	42
b. Service Renewal	42
c. Share Settings	43
d. Available Panels	43
e. User Profile Settings	44
f. Access Settings	44
5. Panel Settings	47
a. Panel Name	47
b. Panel Detail	47
c. Notification Settings	48
d. Advanced Settings	48
6. Activity Log	50
7. Settings	51

a. Account	51
b. Share	51
c. Album	52
d. Tool	52
e. Mobile Data Reminder	52
f. Call Settings	52
g. Site Management	53
h. Site Notice	54
i. User Help	54
j. About	54
Local Web Interface Operation	55
Local Config	55
Dtmf Config	56
Screensavers	56
User Management	56
Maintenance	57
App Updates	57
Firmware Updates	57
Warranty	57
Certifications	58
CE-RED	58
FCC	58

## Technical Specifications

GENERAL	
Housing	Powder-coated Aluminium
Weatherproof	IP65
Impact Rating	IK07
Approvals	CE-RED, FCC, ROHS
Dimensions	<u>Flush</u> - 304mm (H), 136mm (W), 40mm (D) <u>Surface</u> - 320mm (H), 160mm (W), 74mm (D)
Operating Temp	-40 ~ +65
Power Supply	12-15v DC / 48v POE (802.3af)
Power Consumption	12v Max - 1.58A 48v Max - 0.40A
Relays	2
Relay Type	N/C & N/O
Relay Load	3A, 30v DC/250AC
Operating System	Android 12
Alarms	Anti-vandal/Tamper
System Requirements	Minimum 1MB/s Upload Speed
Storage	2GB DDR, 16GB FLASH
SCREEN	
Screen Type	7" IPS LCD
Screen Resolution	600x1024
MEDIA (IMAGE & VIDEO)	
Camera	2 Megapixels
Lens	111° (H), 62° (V)
Display Resolution	Changeable within the app HD - 1080P, SD - 720P, LD - 640*360P
Night Vision	IRCUT, Infrared LED
FACIAL RECOGNITION	

Cameras	Dual Cameras (Liveness Check)
Illumination	White LED (Adjustable)
<b>CARD READER</b>	
Frequency	13.56MHz (MIFARE & NFC) - 24bit
<b>WIEGAND</b>	
Protocol	Wiegand 26 & 34
Functions	Reader & Controller
<b>AUDIO</b>	
Audio Components	Speaker and microphone, noise reduction and echo cancellation.
Audio Streaming	Full Duplex
Audio Codec	G.711U & G.711A
<b>NETWORK</b>	
GSM/Cellular	2G, 3G & 4G
Ethernet	IEEE 802.3
Supported Protocols	TCP/UDP/RTP/RTSP/HTTP/SIP

## Packing Contents

- 1x Obyn Multi Touch Panel Intercom
- 1x PoE Plug
- 1x IEC Lead (Kettle Lead)
- 1x AES Data SIM Card (Unactivated)
- 1x Accessory Bag (Screws, Connectors etc)
- 1x 4G Aerial (Only included in 4G version)

# Product Variations

You can get the system in two different variations, “**Flush Mount**” or “**Surface Mount**”. Both of these can come **with** or **without** a **built-in 4G** module allowing the use of a SIM card to give the system a network connection.



Surface Mount



Flush Mount

# Optional Extra Equipment

- ANDROID MONITOR



- DC PSU (24v 2amp)



- ETHERNET CABLE



- External 4G Modem (Optional for IP models if 4G connection is required)



# Installation Information

Proper installation is essential for optimal system performance and the best user experience. Ensure all instructions in this section are followed carefully.

## 1. Site Survey & Bench Testing

It's important to make sure the site where the system will be installed is suitable. To determine this, we need to ensure certain requirements are met like network speeds, cable distance (DC Power & POE). For more information proceed to the next section.



**Upload Speed**  
I have at least 1.5 Mb **UPLOAD** speed. If not **STOP!** This system may operate intermittently remotely or have delayed **PUSH** notifications.



**Cable Distance**  
My cable run does not exceed 100m in total distance. If it does then a powered switch is required to be fitted in-line to extend the signal.

We also recommend performing a “**Bench Test**” of the system before installing. This will ensure the system is working as it should before it's fully installed. Follow the setup steps below to get started and ensure to default/reset the system once you are done.

## 2. Installation

Ethernet can travel up to roughly 100m/320ft on CAT5/CAT6 cable. Longer distances require a switch every 100m/320ft unless using any specialist equipment.



**MAX DISTANCE 100m (320ft) (LAN)**  
This can be extended by using an ethernet cable extender (purchased separately)

It's also important to take note of the installation height to ensure features like facial recognition work as well as possible. See below graphic with our recommended installation height.

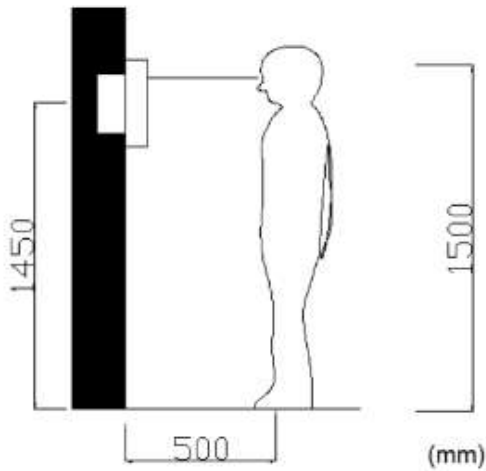

### Camera installation location

Standard installation height of door panel: lens's height is about 1,450mm above the floor.

The two different models of the system need to be installed differently also. So take a note of which model you are working with, either the “**Flush**” or the “**Surface**” and follow the below instructions.

### Flush Mount - Installation

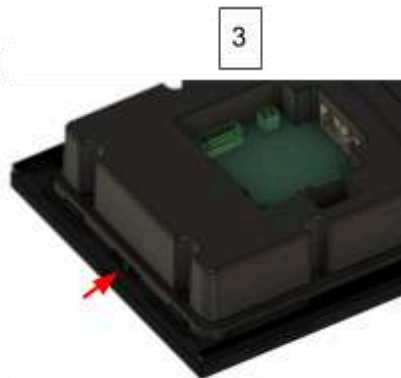
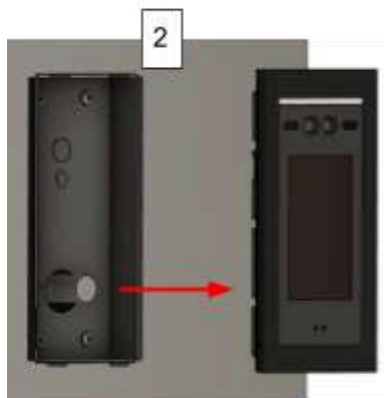
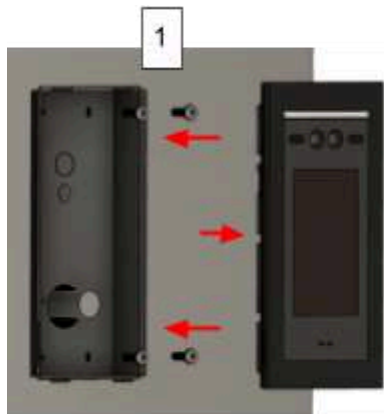

### Flush Mount - Installation

**1a)** Prepare a cut-out in the wall measuring 309mm/12in (H) x 141mm/5.5in (W) x 48mm/1.9in (D) for the back-box.

**1b)** Detach the back-box from the front panel by turning the security screw all the way to the right. Then fix it to the wall with screws.

**2)** Pull the required cables through and connect them to the panel.

**3)** Make sure the security screw is fully inserted into the panel. Achieve this by turning it fully to the right.

**4)** Attach the front panel to the back-box again. Tighten the security screw to grip against the back-box by turning it to the left

### INGRESS PROTECTION



We recommend sealing all entry holes for prevention of insects that can cause issues with a risk of shorting out components.



To maintain the IP65 rating please follow the sealing instructions. (available online)

## Surface Mount - Installation

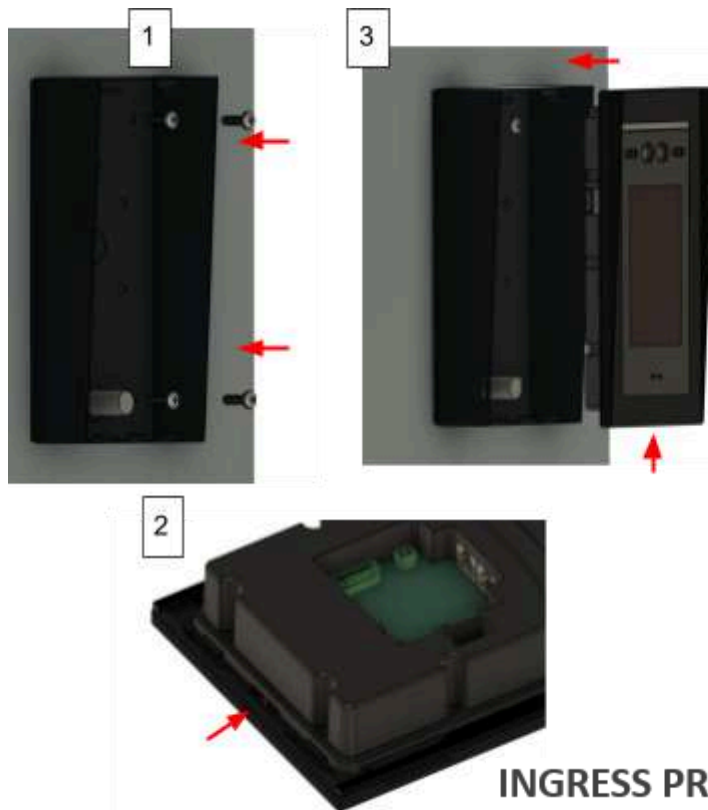

### Surface Mount - Installation

**1)** Detach the back-box from the front panel by turning the security screw all the way to the right. Then fix it to the wall with screws.

Pull the required cables through and connect them to the panel.

**2)** Make sure the security screw is fully inserted into the panel. Achieve this by turning it fully to the right.

**3)** Attach the front panel to the back-box again. Tighten the security screw to grip against the back-box by turning it to the left.

### INGRESS PROTECTION



We recommend sealing all entry holes for prevention of insects that can cause issues with a risk of shorting out components.



To maintain the IP65 rating please follow the sealing instructions. (available online)

### 3. Wiring Diagram

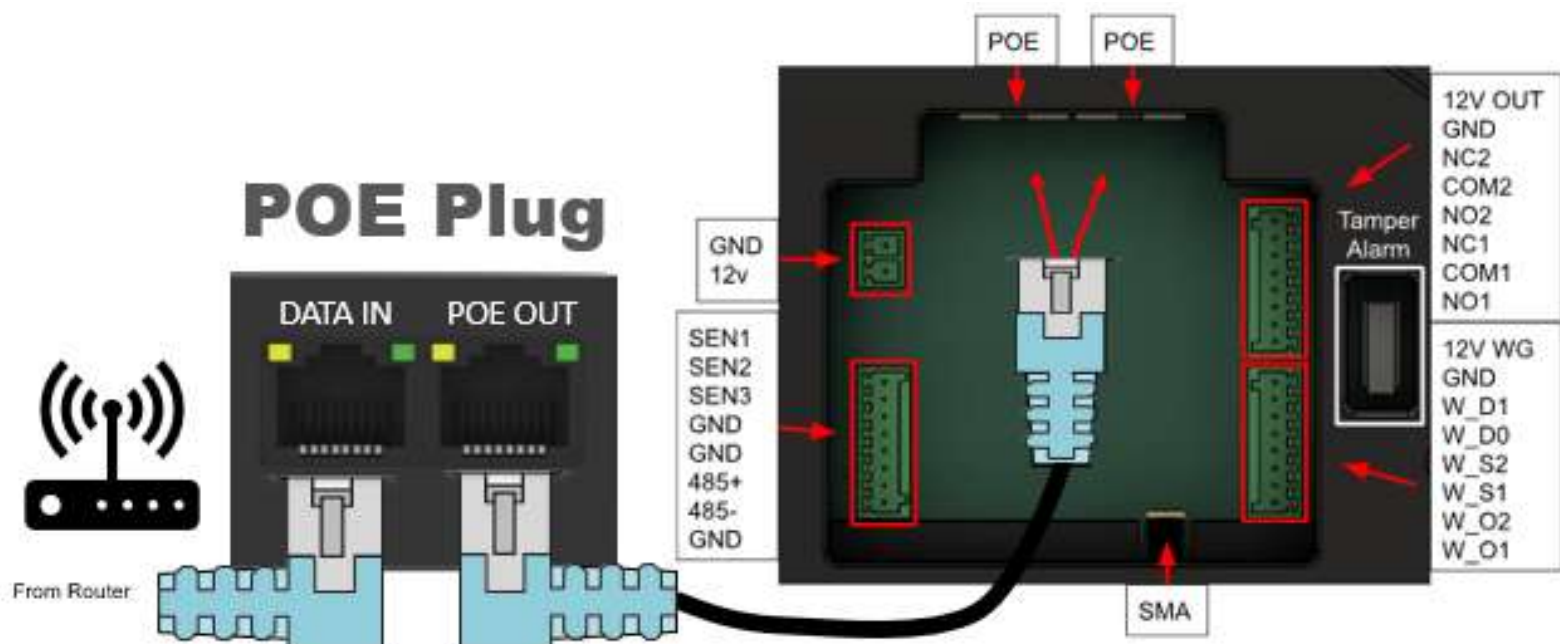

**POE:** Provide both power and network, you can choose either port to supply power & network connectivity.

**12V/GND:** Supply power when POE is not in use.

**SEN1/2/3:** Signal input to open relay, input for exit buttons.

**485+/-:** Interface for elevator controller (Model No:DPA8LCT).

**12V OUT/GND:** 12V power output for lock.

**NO2/COM2/NC2:** NO/NC relay terminal 2.

**NO1/COM1/NC1:** NO/NC relay terminal 1.

**12V WG:** Wiegand device power supply.

**W\_D1/0:** Wiegand input interface for wiegand access control.

**W\_O1/2:** Wiegand output interface for wiegand access control.

**SMA:** Connection for 4G aerial.

#### 4. Relay Connections

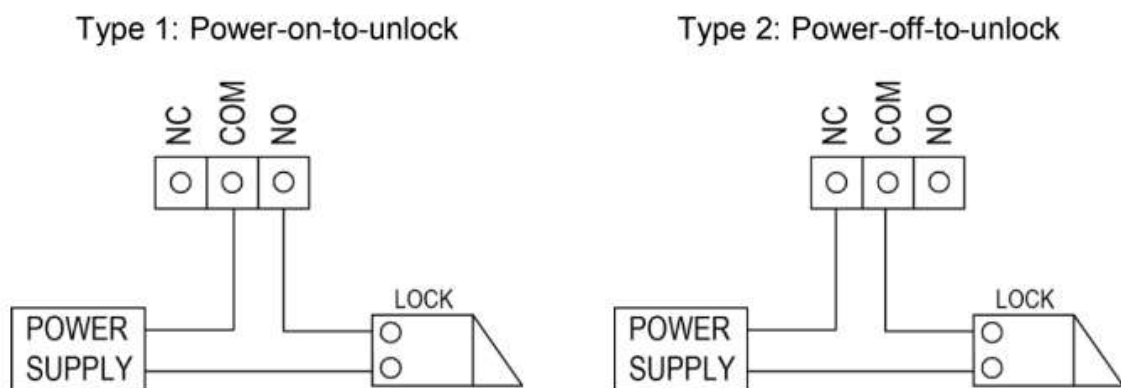

**Note:**

- An external power supply must be used according to the lock.
- The door lock is limited to 30V, 2A.
- Both the entrance panel and building panel support 2 NO/NC locks.

## 5. Power

Powering the panel can be done either via 12v DC or 48v POE. Both of which the system should come with.

### a. 12v DC

When using DC power it is required to stay within a certain distance depending on the type or thickness of cable used. Our general recommendations are as follows:

Up to 2 metres (6 feet) - Use minimum 0.5mm<sup>2</sup>/ 22 gauge cable.

Up to 4 metres (12 feet) - Use minimum 1mm<sup>2</sup> / 20 gauge cable.

Up to 8 metres (25 feet) - Use minimum 1.5mm<sup>2</sup> / 18 gauge cable.

### b. 48v POE

When using POE to power the system it's important to note that the max distance Ethernet can travel is 100m/320ft. This means the distance between the power source and the panel cannot be greater than this.

## 6. Network Connection

When it comes to connecting the panel to a network this can be done in two ways.

### a. Ethernet

You can connect an ethernet cable directly into one of the RJ45 ports that the panel has. Both of these ports support DHCP, and if you wish you may also enable static IP for both. It does not matter which of the two ports you use.

**Note:** Ethernet can travel up to roughly 100m/320ft on CAT5/CAT6 cable. Longer distances require a switch every 100m/320ft unless using any specialist equipment.

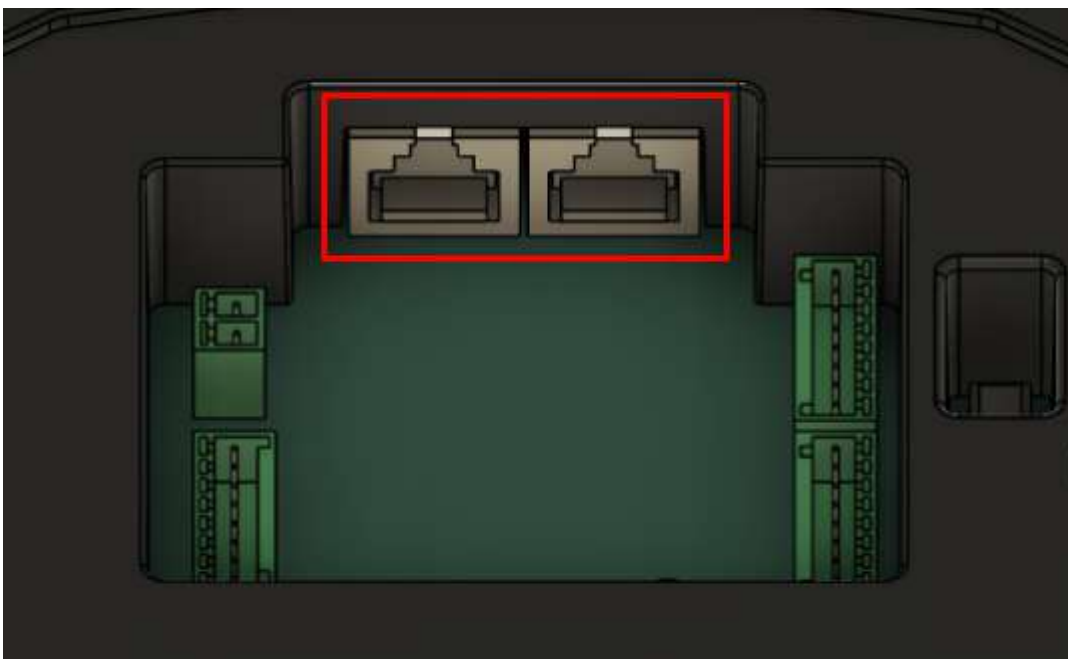

b. 4G

If your panel is a 4G model you can use the built-in 4G module on the panel. This requires a LTE/4G aerial and a working SIM with data on it. It's important to note however if you are using the 4G you will need to power down the system before inputting/swapping a SIM card.

**Note:** Use of the 4G module will require a gsm/cellular antenna to be connected to the panel's SMA connector in order to get a signal.

To access the 4G module, the back of the unit will need to be removed. You will then find the module located at the bottom of the panel.

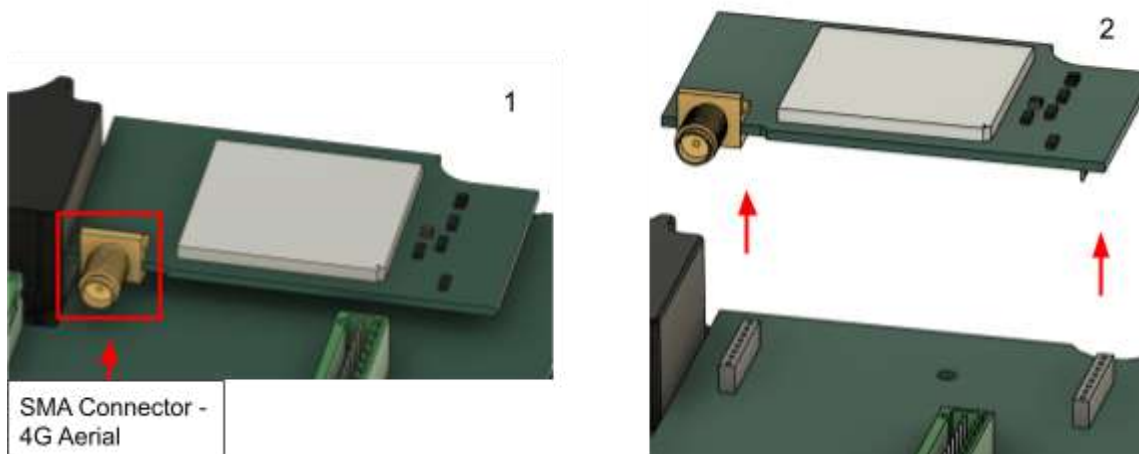

The SIM is inserted on the underside of the module and needs to be lifted off the main PCB for this action to be done. Make sure the device is powered down before doing any of this.

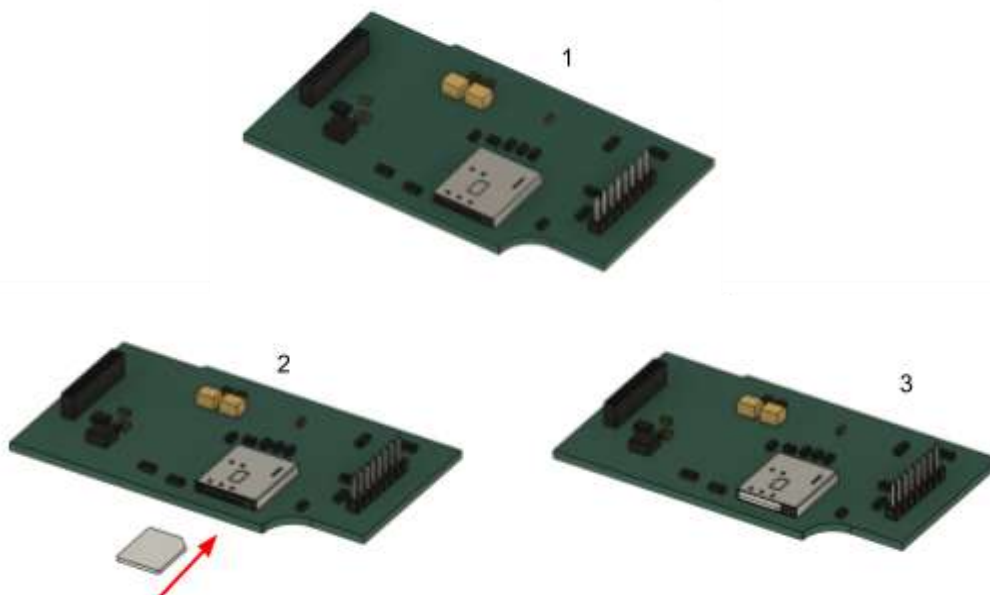

After inserting the SIM card, carefully reposition the module, ensuring all pins securely connect to the main PCB. Once properly seated, reattach the back cover and power on the panel. If the 4G connection is active, the 4G icon should appear on the display, as shown in the image below.

**Note:** You may need to power the system off/on 1-2 times to establish the 4G connection.

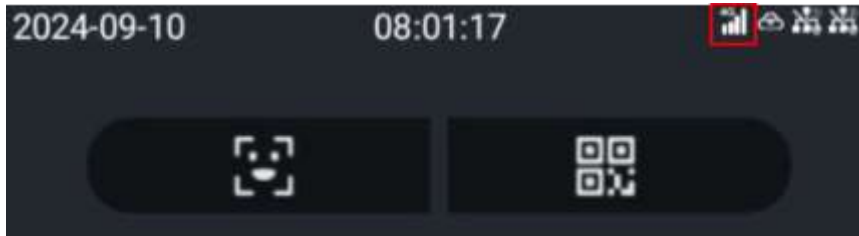

## Setup

### 1. Account Creation

Once the panel has been installed & powered up you can start the setup process. To get started you will need to navigate to our management portal and create an account: [Obyn Multi - Management Portal](#)

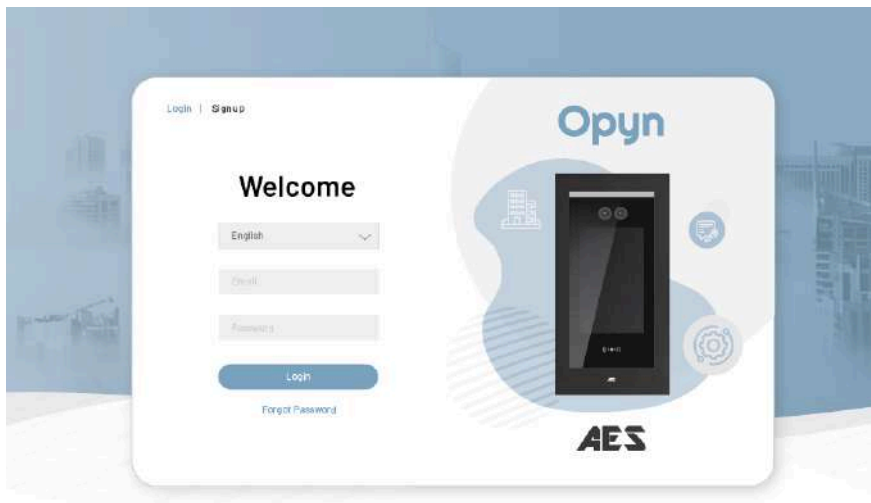

### 2. Create a company

First you will need to create a company. You may create additional companies later if needed.

Create Company✕

Company Name \*

Cancel

Confirm

### 3. Create a site

A site covers the entire installation project. You can think of it in the context of a business park or an apartment complex, where the site encompasses all the panels & users within. Simply give the site the appropriate name & address. These can both be edited at a later time if needed.

**Example:**

*Site Name - AES Test Site*

*Address - 123 Test Avenue*

The screenshot shows a modal dialog box titled "Add" with a close button (X) in the top right corner. Inside the dialog, there are two text input fields. The first field is labeled "Site Name \*" and the second is labeled "Address \*". Below the input fields, there are two buttons: "Cancel" and "Confirm".

### 4. Create a block

A block or several blocks can now be added depending on the requirements of the site. It's easiest to think of a "block" as an apartment block or a unit in a business park. You will need to enter a name and a number for each block. This information can be edited at a later time.

**Example:**

*Blocks Name - Unit 1A or Unit 1B*

*Block Number - 1 or 2*

**Note:** *The block number can only contain numerals and cannot start with a 0.*

The screenshot shows a modal dialog box titled "Add" with a close button (X) in the top right corner. Inside the dialog, there are two text input fields. The first field is labeled "Blocks Name \*" and the second is labeled "Blocks Number \*". Below the input fields, there are two buttons: "Cancel" and "Confirm".

## 5. Create a panel

### Attaching a Panel

1. Enter the required panel information and assign it to a **“Block”**. This gives all users in the block access to the panel.
2. To make the panel available to the entire site, select **“Sites”** from the dropdown instead of a specific block. This allows all site users to access and be called from the panel. (This is generally used for entrance panels)

(See the “Example Setups” section for more details.)

### Adjusting User Permissions

You can configure the following permissions for user roles:

- View the intercom camera
- Unlock the intercom relays
- Receive calls from the intercom

Most of this information can be updated later if needed.

Create new Panels ✕

<p>Panels Serial Number *</p> <input type="text"/> <p><small>if you can't find serial number please click here &gt;&gt;</small></p>	<p>Role permission control</p> <table><tr><td>Site User</td><td><input type="checkbox"/></td><td><input type="checkbox"/></td><td><input type="checkbox"/></td></tr><tr><td>Site Employee</td><td><input type="checkbox"/></td><td><input type="checkbox"/></td><td><input type="checkbox"/></td></tr><tr><td>Site Other</td><td><input type="checkbox"/></td><td><input type="checkbox"/></td><td><input type="checkbox"/></td></tr></table>	Site User	<input type="checkbox"/>	<input type="checkbox"/>	<input type="checkbox"/>	Site Employee	<input type="checkbox"/>	<input type="checkbox"/>	<input type="checkbox"/>	Site Other	<input type="checkbox"/>	<input type="checkbox"/>	<input type="checkbox"/>
Site User	<input type="checkbox"/>	<input type="checkbox"/>	<input type="checkbox"/>										
Site Employee	<input type="checkbox"/>	<input type="checkbox"/>	<input type="checkbox"/>										
Site Other	<input type="checkbox"/>	<input type="checkbox"/>	<input type="checkbox"/>										
<p>Panels Security Code *</p> <input type="text"/> <p><small>if you can't find security code please click here &gt;&gt;</small></p>													
<p>Panels Name *</p> <input type="text"/>													
<p>Sites Or Blocks *</p> <input type="text" value="Sites/Blocks"/>													

## 6. Setup users

### Adding Users to the Panel

1. Fill in the user's details and select their block, house/apartment number, and role.
2. Assign a licence if already purchased (or do this later after reading the "Licences" section).

### Block Assignment:

- Select "**Sites**" to make the user a "site user," granting access only to site panels.
- Assign them to a "**Block**" to provide access to their block's panels and site panels.

(See the "Example Setups" section for more details.)

### User Onboarding:

- After saving, an email invite is sent to the user.
- The email includes instructions to download the AES Olyn app, create an account, and scan a QR code or click a link.
- Scanning the QR code or using the link prompts the user to accept the invitation to the site. Once accepted, the user is added to the panel's contact list and can operate the system.

Add Site User ✕

User email *	User Role *
<input type="text"/>	<input type="text" value="User Role"/>
First Name *	Surname
<input type="text"/>	<input type="text"/>
SitesOrBlocks *	Available activation codes
<input type="text" value="Sites/Blocks"/>	<input type="checkbox"/> 30 Days Remaining Quantity: 47
House Number *	
<input type="text"/>	

## 7. Licences

To operate the panel via the app, users need an assigned licence.

- **Purchasing Licences:** Buy licences directly from AES through the management portal under the “Payments” tab. For details, see the “Management Portal Operation” section.
- **Licence Duration:** The licence duration begins when assigned to a user, not at the time of purchase.
- **Assigning Licences:** Licences can be assigned:
  - When creating a user.
  - When editing a user.
  - Using the “service activation” feature.
- **Admin Monitoring:** Check each user's remaining licence duration in the management portal.
- **User Monitoring:** Users can view their licence duration in the mobile app.

**Note:** Each apartment requires a licence assigned to the main user. The main user can share apartment access with others via the mobile app.

The image displays three screenshots from a management portal interface:

- Top Left: Add New User** - A form for creating a new user. It includes fields for User email, User Role, First Name, Surname, Email, and House Number. A table of available licenses is highlighted with a red box, showing two options: "License" with a remaining quantity of 131, and "License" with a remaining quantity of 30. An "Add User" button is located at the bottom right.
- Top Right: Edit User** - A form for editing an existing user. It includes fields for User Account, User Role, First Name, Surname, and House Number. A "Service Status" section shows "In Use" and "Services Remaining: 30 Days". An "Assign" button is highlighted with a red box.
- Bottom: Service Activation** - A modal window for activating services. It features a search bar and a table with columns for #, User Name, Service Status, and Services Remaining. The table contains one entry for "Test Test" with a status of "In Use" and 30 days remaining. Below the table, there is a "Total: 1" and "Select: 0" summary, followed by two license options: "License Package (Basic Edition) for 30 days" (Remaining Quantity: 131) and "License Package (Basic Edition) for 1 days" (Remaining Quantity: 30). "Cancel" and "Activation" buttons are at the bottom.

## 8. Example Setups

Here are three common setups for the Oryn Multi system. These examples won't cover every scenario but should provide enough guidance for most situations.

### a. **Apartment Buildings**

1. Create a site with one block to represent one building.
2. Assign panels and users to the block.
3. For multiple buildings, create additional blocks for each building and assign panels and users accordingly.

Users will have access to the panels assigned to their block and appear as contacts for visitors to call.

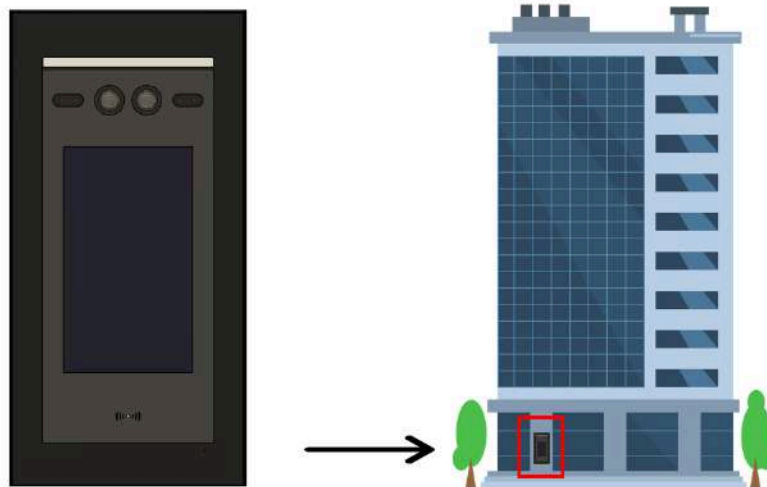

### b. **Gated Community**

1. Create a site and a single block representing the entire community.
2. Assign a panel for each entrance and invite residents as users.

All users will have access to the entrance panel(s) and appear as contacts for visitors to call.

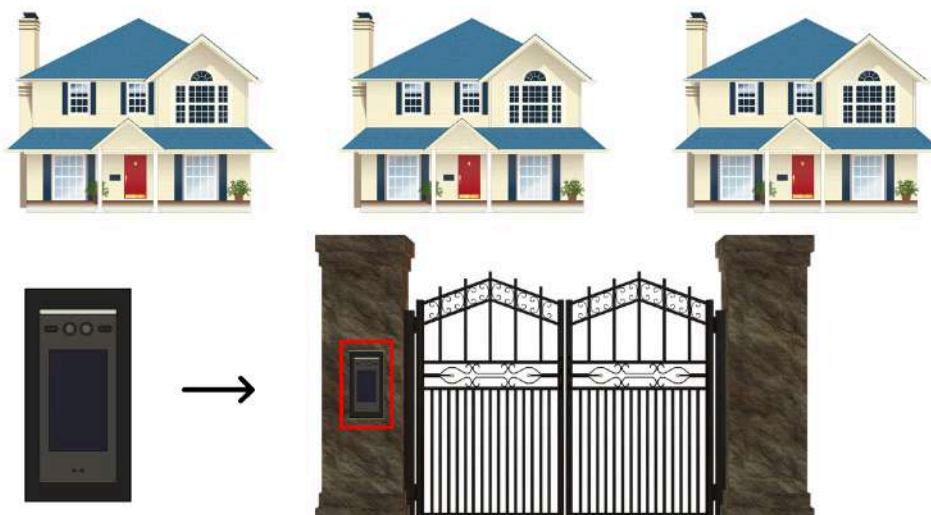

c. **Business Park**

For a business park, distinguish between “block panels” and “site panels”:

- Block Panel: Accessible only by users in its block.
- Site Panel: Accessible by all users in the site.

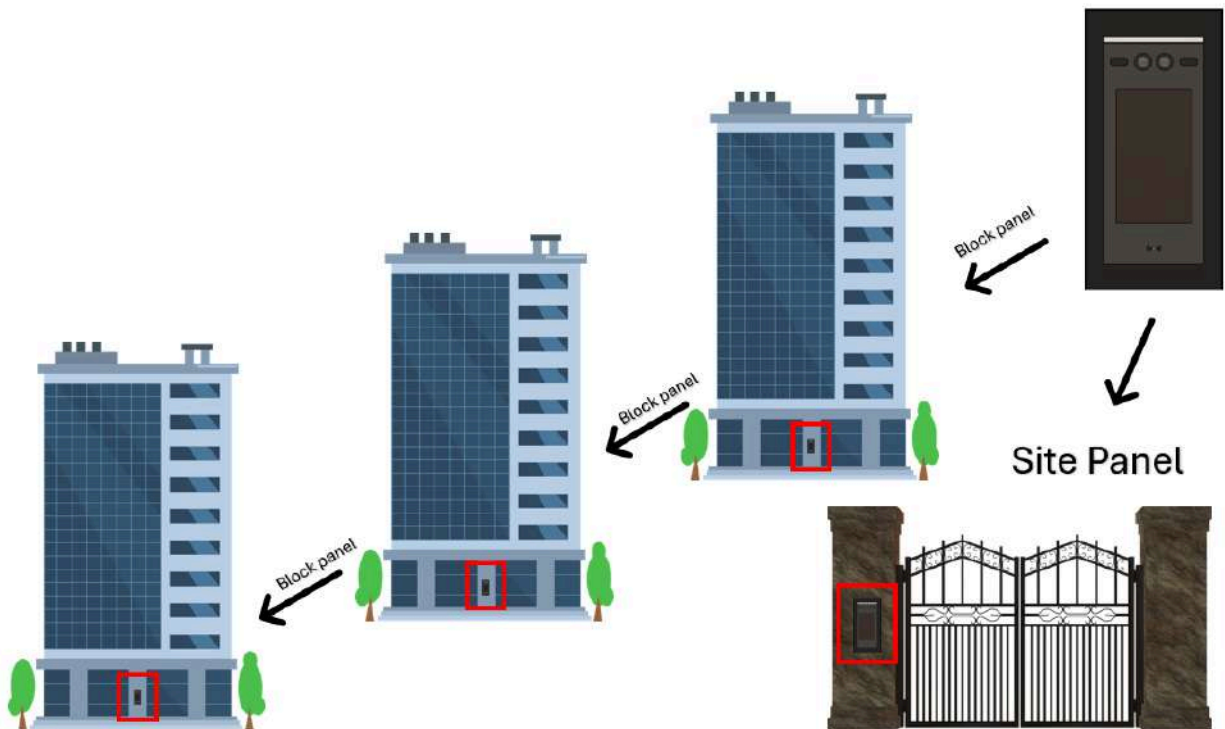

Example:

For three buildings entrance:

- Create three blocks and assign panels and users to each block.
- Add a site panel for the entrance by selecting the “Sites” option in the dropdown.

The “site” panel will display all blocks and their users in the contact list.

# Panel Operation

## 1. Icon Meaning

At the top right corner of the screen on the panel you will find 4 icons. They represent the 4G, Server and Ethernet port connections. Should either of these connections not be in use or not functioning they will appear with a line going through them.

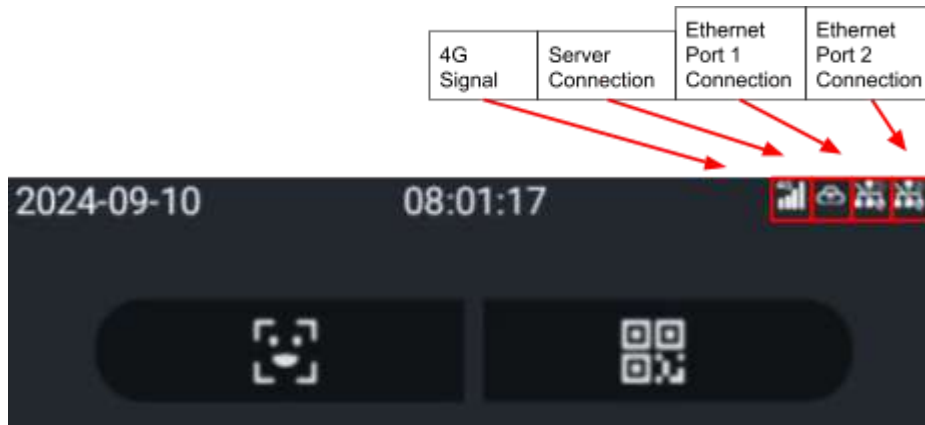

## 2. Unlock Page

In standby mode, once the screen is pressed or a face is detected the screen will wake up and show the unlocking page and the different ways to activate the locks of the system.

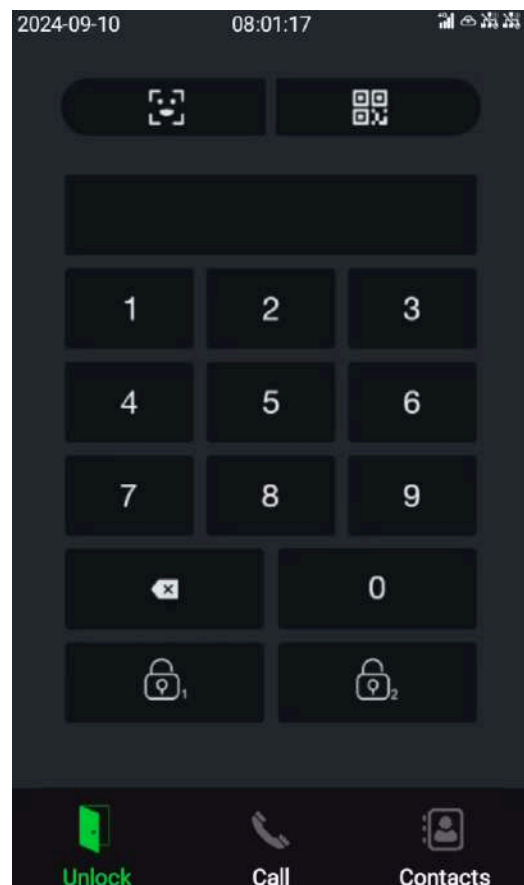

### **Note:**

- The white LED will also be lit up with the screen, if the LED is enabled.
- To light up the screen, the face detect range is 1- 2 metres.
- The device will go back to standby mode, if no face is detected or hasn't been touched for 30 seconds.
- The unlock functions can be enabled/disabled in the access settings.
- Swipe card distance  $\leq 20\text{mm}$ .



### a. Keypad Code

Using a programmed keypad code is done simply by entering the code using the keys on the screen followed by selecting the lock you wish to activate. If the keypad code is correct and accepted there will be a voice prompt to confirm. Your keypad code may be set to only allow access to one or both. Should you try to access a lock you do not have access to you will be met with an error.

Pressing this icon  will activate lock 1. Whilst pressing this icon  will activate lock 2.

Keypad codes can be added manually on the panel or users can add it themselves remotely using the mobile app.

**Note:** Keypad code max capacity is 10,000

### b. Facial Recognition

You can press the  icon to activate facial recognition. Stand before the panel within 1 metre and make sure only one face is in the recognition area. If the face is already added to the system it will give a voice prompt. Otherwise it will give a pop-up error on the screen. Facial IDs can be added via the panel manually or users can add it themselves remotely using the mobile app.

**Note:** The facial recognition scan lasts for 15 seconds & max capacity for facial IDs is 10,000

### c. QR Code

You can press the  icon to activate the QR code scan. Simply hold the QR code before the panel within 1 metre. If the QR code is added and recognized a voice prompt can be heard. Otherwise it will give a pop-up error on the screen. QR codes can be added via the panel manually or users can add it themselves remotely using the mobile app.

**Note:** QR code max capacity is 10,000



### d. Prox Card

You can swipe any MIFARE prox card that has been added to the system. By default a quick/short swipe will unlock “Lock 1” and a long swipe will unlock “Lock 2”. This can be changed and adjusted in the “Settings” of the panel. Prox cards have to be added manually on the panel. For more info on this refer to the “Panel Operation” section.

**Note:** Prox card max capacity is 10,000

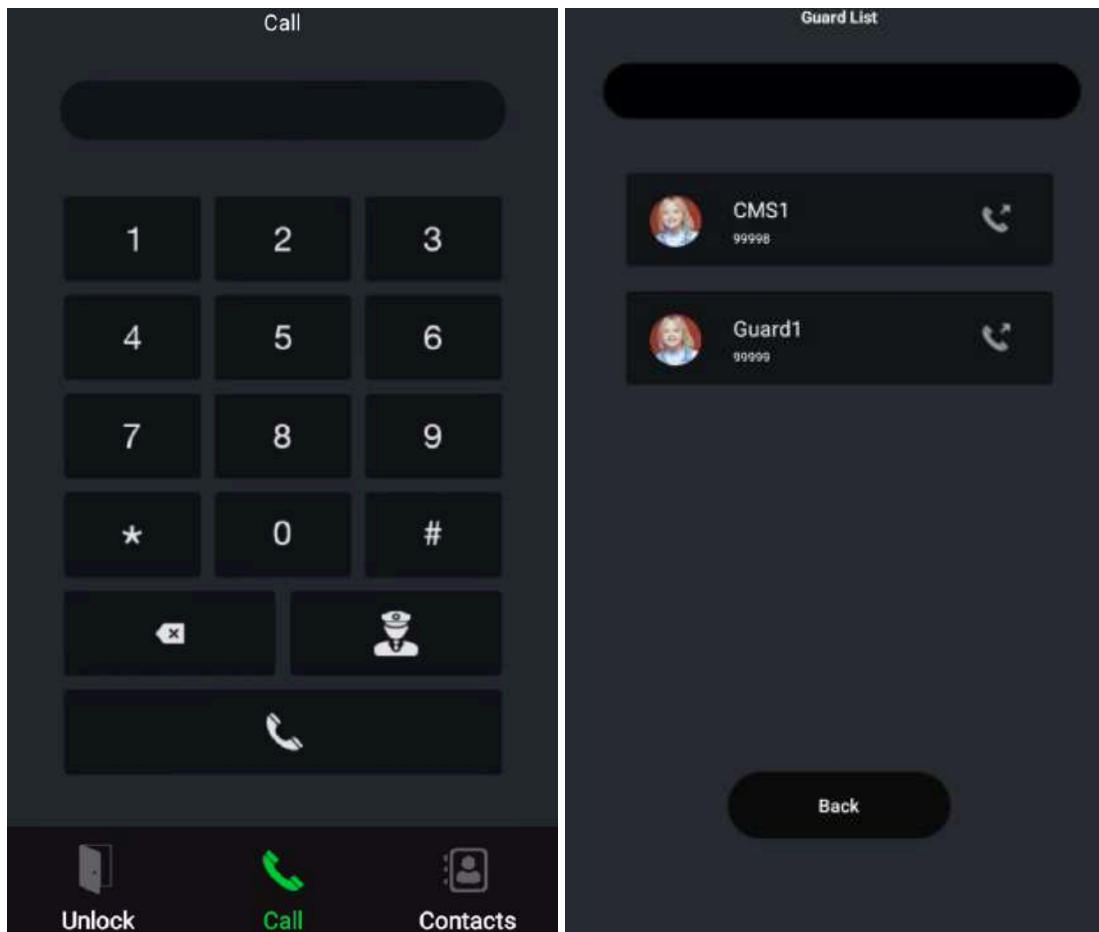
### 3. Call Page



You can input the room number you want to call and press the  icon to initiate the call. Use the  icon to delete digits. During a call you may hang up at any time using the  icon.

Pressing the  icon will enter the guard list page. You may search for the guard you want or simply press the nameplate of the desired guard to initiate a call. If there is only one guard added to the system, pressing the guard icon will initiate a call immediately.

**Note:** The call rings for 30 seconds, and the conversation can last for 3 minutes.

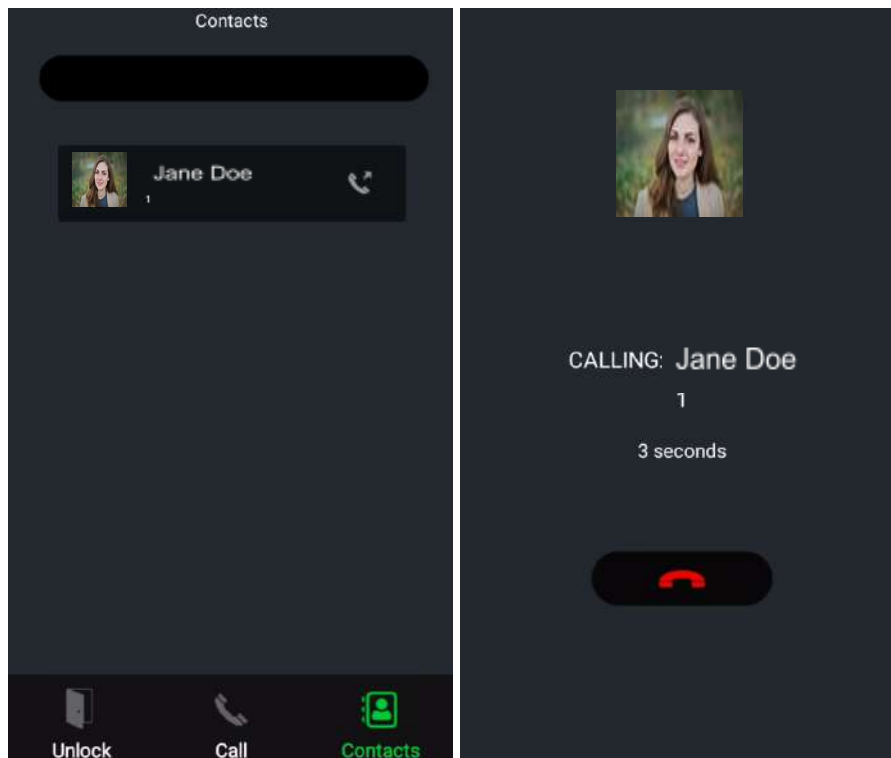

#### 4. Contacts Page



In the contacts page you can search for residents or press their nameplate from the contact list on screen. Pressing the nameplate will initiate a call.

**Note:** The call rings for 30 seconds, and the conversation can last for 3 minutes.

#### 5. Settings Page

To enter the settings of the panel you need to navigate to the “Call Page”. From here press the  followed by  then enter 99 into the keypad. A pop-up will now appear requiring a password to gain access to the settings page. (Default password is 0000)

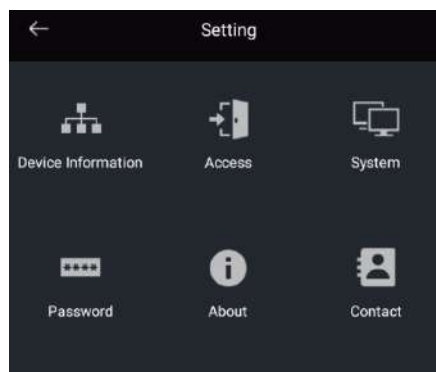

a. **Device Information**

In this page you can select between DHCP or Static IP for each of the panels Ethernet ports.

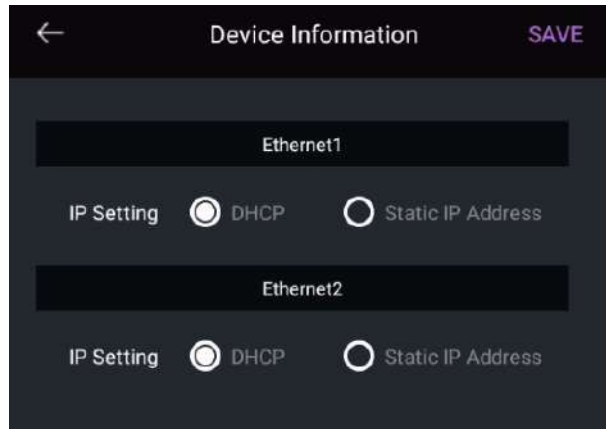

b. **Access**

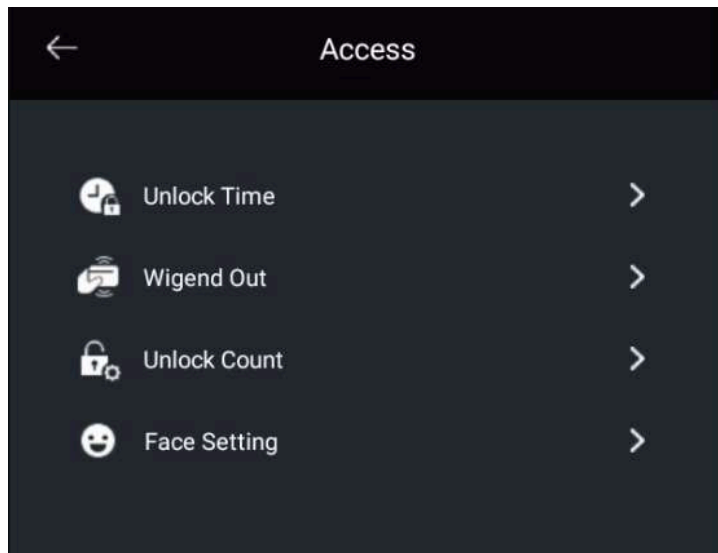

**Unlock Time** - You can set the opening time for both lock 1 and lock 2. Time range is 1-15 seconds (default time is, lock 1 = 1 seconds; lock 2 = 5 seconds).

**Unlock Button Mode** - You can choose the default state of the second lock.

**Wiegand Out** - You can enable or disable the Wiegand out port.

**Unlock Count** - Setting this to 1 will disable use of Lock 2. Setting this to 2 will allow use of both locks.

**Face Setting** - You can adjust environment mode between indoor & outdoor to fit your installation. Liveliness check can also be enabled, and you can adjust its sensitivity.

### c. System

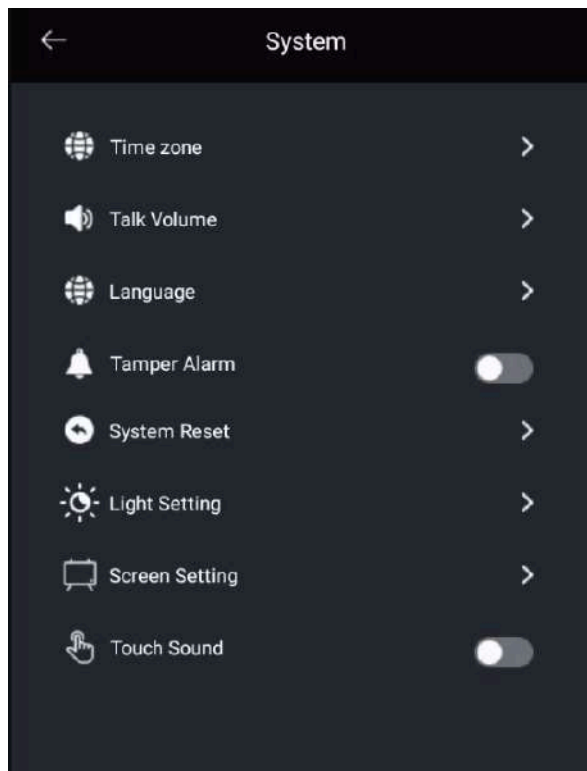

**Time Zone** - Here you can adjust the time of the panel to match what you require.

**Talk Volume** - Lets you adjust the talking volume from 1-10 (default is 5).

**Language** - You can change the language of the panel.

**Tamper Alarm** - You enable or disable the tamper alarm. If enabled the alarm will go off when the tamper button is released. Cloud management platform and mobile app users will be notified.

**System Reset** - If you press yes this will default the system back to factory settings.

**Light Setting** - You can set the corresponding LED brightness for day (default: 1) and night (default: 10). The screen brightness can also be adjusted (default: 100).

**Screen Setting** - You can choose if you want the screen to wake up by touch or by face detection (default: Touch).

**Touch Sound** - Enable or disable the sound made from touching the panel screen.

### d. Password

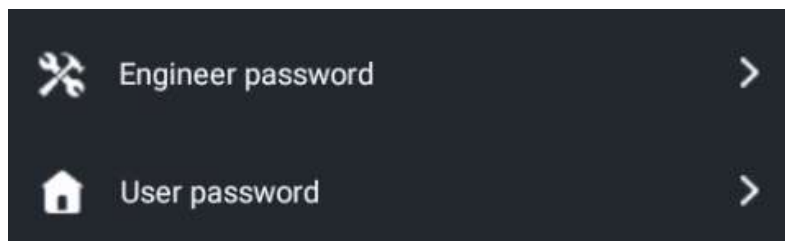

**Engineer password** - You can change the engineer's password (default is 0000).

**User password** - You can change the user password for the Contacts page (default is 123321).

#### e. About

Here you can check the device information including firmware version, serial number and more.

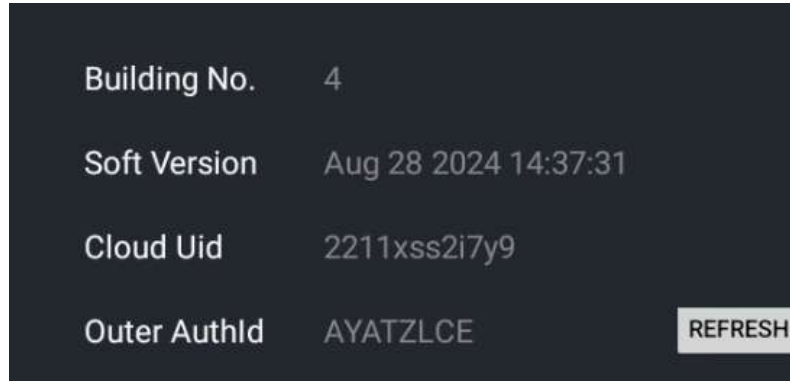

#### f. Contact

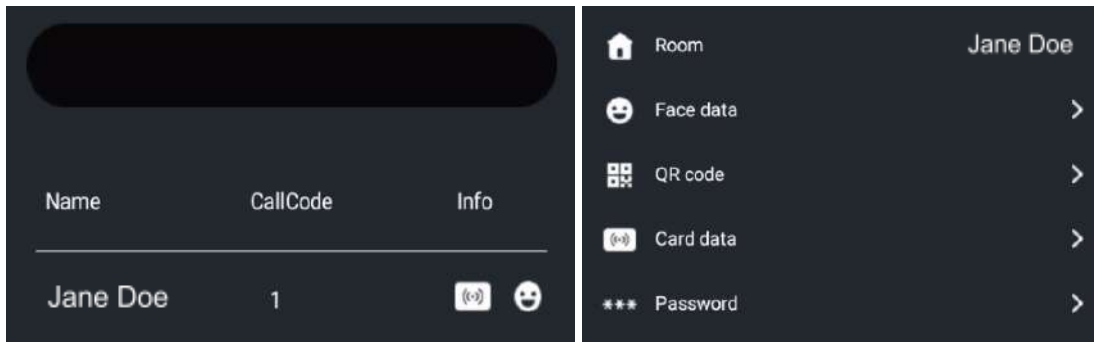

If you click on the “Contact” option you will be met with a pop-up asking you to enter a password. By default this password is “123321” but can be changed in the “Password” page.

In “Contacts” you can manage the users registered in the panel.

**Face data** - You can add or delete Face ID. To add Face ID, stand 1 metre before the door station, press the camera icon, and name the Face ID, it will pop up ‘add face successfully!’. If failed, you need to modify the face position and angle according to the prompt. You can delete the Face IDs by pressing the delete icon.

**QR code** - You can manage and delete the existing QR codes.

**Card data** - You can add and delete the IC/ID card. To add card, press ‘Add card’, and swipe the IC or ID card at the lower card-read area of the device. You can delete the cards by pressing the delete icon. We recommend adding the cards via the management portal rather than directly on the panel.

**Password** - You can manage the passwords/keypad codes for users. To add password, press ‘Add password’, type the password and retype to confirm.

# Management Portal Operation

## 1. Company Dashboard

Link: [Opyn Multi - Management Portal](#)

This is the homepage of the portal. Here you can see all your sites, create additional admins and look at your purchase records for any licences. You can also create additional companies and swap between them using the drop-down menu in the top right corner.

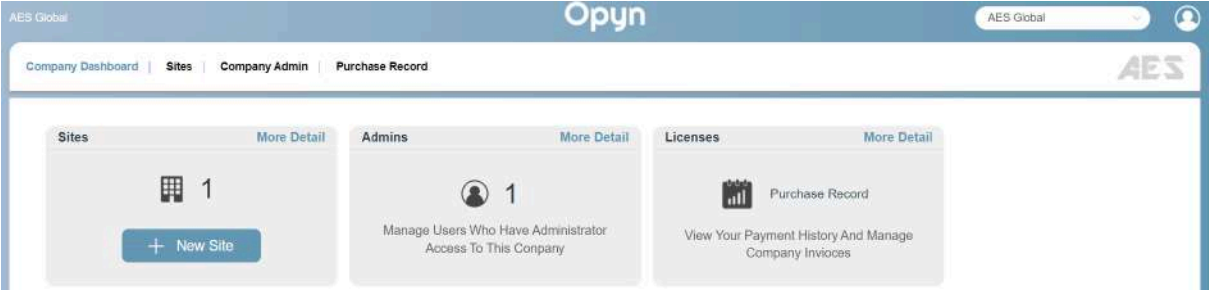

### a. Sites

View, edit or delete current sites or create new ones.

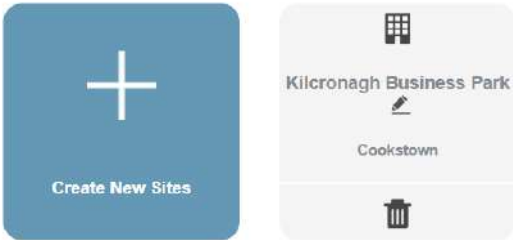

### b. Company Admin

Here you have the ability to edit or delete any current admins while also adding new ones.



Add Admin ✕

Email Account \*

Please Enter The Registered Account.

**User Role Company Admin:**  
 Manages All Sites And Site Admins.  
 Makes Payments And Has Access To Billing Info.

Cancel
Search

### c. Purchase Record

Keep track of all your licence purchases here. Filter by site or time frame.

Sites v

Start Time

- End Time

Search

Sites	License Name	Quantity	Amount	Admin Name	Create Date
Kilcronagh Business Park	License Package (Basic Edition) for 30 days	50	\$50		2024-07-01 16:18:42

## 2. Site Dashboard

From the site dashboard you have many options, which we will cover individually but here you can get a good overview of the blocks, panels and users for the site.

Site Dashboard | Blocks | Panels | Site Users | Operation Log | Panel Log | Site Licenses | Payments | Notice
AES

**Blocks** More Detail

2

Blocks On Site

Add Blocks

**Panels** See All Panels

2

Added Devices

Create new Panels

Normal	: 2
Need Configuration	0
Check Fail	0
Offline	0

**Users** See All Users

2

Added user

Add Users

Licenses Normal	: 2
Licenses Expired	--
Not Opened	--
Not Accepted	0

**Licenses** More Detail

License Package (Basic Edition) for 30 days

Remaining Quantity: 47

Buy More

#### a. Blocks

In the blocks section we can edit the block name and block number. You will also be able to see any panels assigned to this block along with any users assigned to these panels.

#### b. Panels

In the panels section we have access to several settings, these include being able to edit the panel details, configure the role permissions, add a "SIP" server, change the DTMF settings and add "Guards".

- Panels Detail
Access Control
Sip Settings
DTMF Setting
Guard Settings
CCTV Settings

**Access Control** - Adjust the role permissions here as you wish. The 3 permissions and what they each control are covered in the “Setup” section of this manual.

**Sip Settings** - You can add multiple SIP servers here for use with the panel. Simply add the information requested. Assigning the SIP servers is done in the “Site Users” section.

**DTMF Settings** - Adjusting the 3 options on this page will change that key to press on a SIP device to activate Lock 1 or Lock 2, and in some cases also initiate the 2-way speech.

**Guard Settings** - Here you can add guards to the panel. You can add several of these and they can be called from the panel using the guard icon. For more info refer to the “Panel Operation” section.

Create New Guard ✕

Guard Name \*

Test Guard 1

Sites Or Blocks \*      Address \*

Unit 4C      Jane Doe

Cancel      Confirm

**CCTV Settings** - Here you can add IP cameras to the system using the ONVIF protocol.

Simply enter the IP address of the desired camera, along with a name to identify it. Then the username and password that has been set on the camera. Ensure ONVIF is enabled/supported on your IP camera for this to work.

Once added it will now display in the app as another camera that can be viewed along with the panel’s own camera.

Add Camera ✕

Name \*

Test

IP/RTSP Url \*

192.168.1.180

User Name \*

admin

Password \*

.....

Stream \*

Main Stream

Cancel      Confirm

### c. Site Users

In this section we can edit the user details, update the users licence, see any panels they have access to and configure SIP settings.



**User Details** - You can edit most of the user's information including the block they are assigned to and their house/apartment number. Licences can also be assigned to a user from this page.

**Devices** - See all the panels the user has access to. There is also a toggle here for "Access Status" if you need to remove access for a time without having to delete them from the system.

**Sip Settings** - Here you can set up SIP calling for this user. If using an added SIP server select it from the dropdown along with the account info. If using P2P mode then simply add the IP address of the target device.

**Note:** Use of SIP P2P mode requires both the panel and the target device to be on the same network (IP Scheme).

**Card Settings** - Here you can add your proximity cards/tags (IC/ID) to the different users. When adding a card you will need to input a name to make it easily distinguishable, followed by the full card number (8-10 digits) and which relay/lock to operate. There are a couple of ways to add the card number:

1. Manual Input (Full Card Number) - If you know the full digit card number you can enter this here and confirm to add.

A screenshot of a modal dialog box titled 'Add Card' with a close button (X) in the top right corner. Below the title bar, there are two radio button options: 'Full Card Number' (which is selected) and 'Facility Code&Card Number'. Below these options is a large, empty text input field. At the bottom of the dialog, there are two buttons: 'Cancel' and 'Confirm'.

2. Manual Input (Facility Code & Card Number) - If you only know the 3 digit facility code and the 5 digit card number add this in here to calculate your full card number.

Add Card✕

Full Card Number     Facility Code&Card Number

-

Cancel

Confirm

3. Reader - Connect a reader to your computer in order to scan the card and get the full card number. You need to make sure to have the correct drivers installed to operate the reader. This can be downloaded from the portal. The reader can be purchased from AES.

Add Card✕



Reader is not detected, Please check your driver installation or Cable Connection !

Download Driver

Test Driver

Add Card✕



Please place a card on the reader

After adding the above you will then need to select how many uses this card will have before it expires, and also set a validity time. The final part of the adding process is choosing which panels to sync it to. You can select 1 or more panels that you have access to in which this card will be added to. The number of uses and the validity time can be toggled to “Unlimited” and “Forever” to make the card work permanently.

**Note:** The system used 24-bits as its standard, if your card is 32-bit it will be converted to 24-bit and the ID displayed on this portal will be different from what may be printed on your card.

Add Card Number
✕

Name \*

Full Card Number \*      Unlock Option \*

Please Select

Manual Input     Reader

---

Limited            Number Of Uses

Unlimited

---

Validity Time     Start Time    ~     End Time

Forever:

Panel Sync

Production

Engineering

Entrance

Cancel

Confirm

#### d. Operation Log

This log keeps track of all managerial operations done on the portal. It will give you the user name of the person who carried out the operation along with the operation type and the time.

-

Search

User Name	Operation module	Operation Content	Create Date
-	Notice	Release device notice	2024-09-04 12:39:31
-	Notice	Create device notice	2024-09-04 12:39:28
-	Site Licenses	Buy Licenses	2024-09-04 12:34:02
-	Notice	Withdraw device notice	2024-07-16 08:32:33
Jane Doe	Panels	Delete Ddevice guard config	2024-07-16 08:31:53
Saaland Thor	Panels	Create Ddevice guard config	2024-07-16 08:31:27
Jane Doe	Panels	Update Panels	2024-07-16 08:26:17
-	Panels	Binding Panels	2024-07-16 08:25:52
-	Notice	Release device notice	2024-07-16 08:09:27
-	Notice	Create device notice	2024-07-16 08:09:18

< 1 2 3 4 >
Go to 1

#### e. Panel Log

The panel log is separated into 3 categories. You can export all these logs as “.xlsx” files.

**Call Log** - Displays both answered and unanswered calls along with who the call was for and a snapshot.

**Access Log** - Displays unlock events such as keypad code, qr code or facial recognition.

**Tamper Log** - Displays any tamper alarm events that may have been set off.

Call Log **Access Log** Tamper Log

Panel  Apartment Number  Unlock Type  Start Time  - End Time

Panel	Blocks/Sites	Apartment Number	User Name	Unlock Type	Status	Time
Test 2	Unit 4C	1	Jane Doe	Unlock Password	Success	2024-09-09 10:20:14
Test	Unit 4C	1	Jane Doe	Unlock Password	Success	2024-09-09 10:20:13
Test 2	Unit 4C	1	Jane Doe	Unlock Password	Success	2024-09-09 10:20:09
Test	Unit 4C	1	Jane Doe	Unlock Password	Success	2024-09-09 10:20:07
Test	Unit 4C	1	Jane Doe	QR Code	Success	2024-09-09 10:19:32
Test 2	Unit 4C	1	Jane Doe	QR Code	Success	2024-09-09 10:19:27

### f. Site Licences

Here you can keep track of how many licences you have remaining available to your site. If you wish to may also buy more from this page, but this can also be done from the “Payments” page.

**Service Licenses** Activation Records

**License Package (Basic Edition) for 30 days**

131

Remaining Quantity

**License Package (Basic Edition) for 1 days**

20

Remaining Quantity

You can also view the records for all activations within your site. Search directly by user name or by licence type to help filter the records as you wish.

**Service Licenses** **Activation Records**

User Name  Licenses Name

Licenses Name	Code	Users	Blocks Name	Create Date
License Package (Basic Edition) for 30 days	--	Test Test	Unit 4 (AES)	2024-11-05 15:11:57

## g. Payments

Here you can purchase licences to be added to your site.



The screenshot shows a modal window titled 'Buy Licenses' with a close button (X) in the top right. Below the title, there is a crown icon and the text 'License Package (Basic Edition) for 30 days \$1 /Person'. Underneath, it says 'Buy Quantity :'. There are four buttons for quantity: '10', '20', '50', and 'Custom Quantity'. Below that, 'Pay Platform :' is followed by radio buttons for 'PayPal' and 'stripe'. At the bottom, 'Pay Amount : \$10' is displayed next to a 'Pay' button.

When buying licences you will need to enter the quantity you want and be sure to select “Stripe” as the payment platform. You will then be prompted with a check-out page which will require you to enter details such as card number and expiry date. After the payment is successful the licences are immediately added to your site.

**Note:** Prices shown in this manual do not reflect actual prices for licences.

The screenshot shows a checkout page for a 'License Package (Basic Edition) for 1 days' priced at '\$10.00' (Qty 10, \$1.00 each). At the top, there is a 'G Pay' button. Below it, there is a link 'Or pay with card'. The form includes an 'Email' field, a 'Card information' section with fields for card number (1234 1234 1234 1234), MM / YY, and CVC, and a 'Cardholder name' field for 'Full name on card'. There is a 'Country or region' dropdown menu set to 'United Kingdom' and a 'Postal code' field. At the bottom, there is a checkbox for 'Securely save my information for 1-click checkout' and a 'Pay' button.

## h. Notice

In this section we can create notices to be sent either to the app users of your site or to the panels. They are divided into 2 separate pages “App Notice” and “Device Notice”.

**App Notice** - This notice type lets you send out a notification to all the app users in your site or you can select specific users. Simply select “Broadcast” or “Private Message”. After this, fill out the required information and click “Create Notice”. The notice will then appear on the “App Notice” list after which you can choose to release, withdraw or delete it.

*We recommend uploading pictures with a 16:9 ratio.*

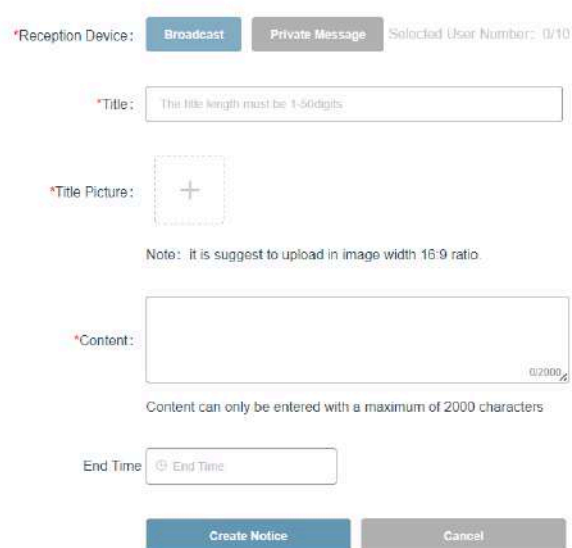

The screenshot shows a web form for creating an App Notice. At the top, there are two radio buttons for "Reception Device": "Broadcast" (selected) and "Private Message". To the right, it says "Selected User Number: 0/10". Below this is a text input field for "Title" with a placeholder "The title length must be 1-50digits". Underneath is a "Title Picture" section with a plus sign icon and a note: "Note: it is suggest to upload in image width 16:9 ratio." Below that is a large text area for "Content" with a "0/2000" character count and a note: "Content can only be entered with a maximum of 2000 characters". At the bottom, there is an "End Time" section with a clock icon and a text input field. Finally, there are two buttons: "Create Notice" (blue) and "Cancel" (grey).

**Device Notice** - This notice type lets you send out a notice either to all panels in your site or you can choose a specific panel. Choose between “Broadcast” or “Choose Device”. Afterwards make sure to fill out all the required information. The notice will then appear in the “Device Notice” list after which you can choose to release, withdraw or delete it.

*We recommend uploading pictures with a 9:16 ratio and 600 x 1024 pixels.*

\*Reception Device: **Broadcast** **Choose Device** Selected Device Number: 0/10

\*Title:

\*Title Picture: 

Note: it is suggest to upload in image width 9:16 ratio.

Time Range:  -

**Create Notice** **Cancel**

# App Operation

The AES Opyn mobile app is crucial for all users in the panel. It allows users to remotely add and manage keypad codes, qr codes and facial IDs. You can also upload a profile picture for the panel's contact list, invite other users to apartments, activate the locks of the panel and more. We will be covering these essential features below.

## 1. Add Intercom to Device

To add an Opyn Multi intercom panel to your AES Opyn app you need to be invited to a site. The management of the site needs to create you as a user in the management portal, after which an email will be sent out containing a QR code & link you can use after you have downloaded the app and signed in.

**Note:** This email may appear in your spam folder, and must be moved to your main inbox in order to view the QR code.

After using the QR code or link you will be prompted with the invitation pop-up asking you if you wish to accept or decline. Should you choose to accept the site and all panels you have access to will automatically populate inside your app.

## 2. Basic Setup & Operation

We will now cover some of the basic operations of the app such as answering a call, activating two-way speech and opening the intercoms relay(s).

### a. Answer Call

#### Android



(iOS)



#### b. Two-Way Speech

To enable two-way speech we need to click the microphone icon on the screen. Afterwards a larger microphone icon will appear, this needs to be pressed to enable the microphone and you can now have a conversation with the visitor.

**Note:** The large microphone icon will turn blue when active.

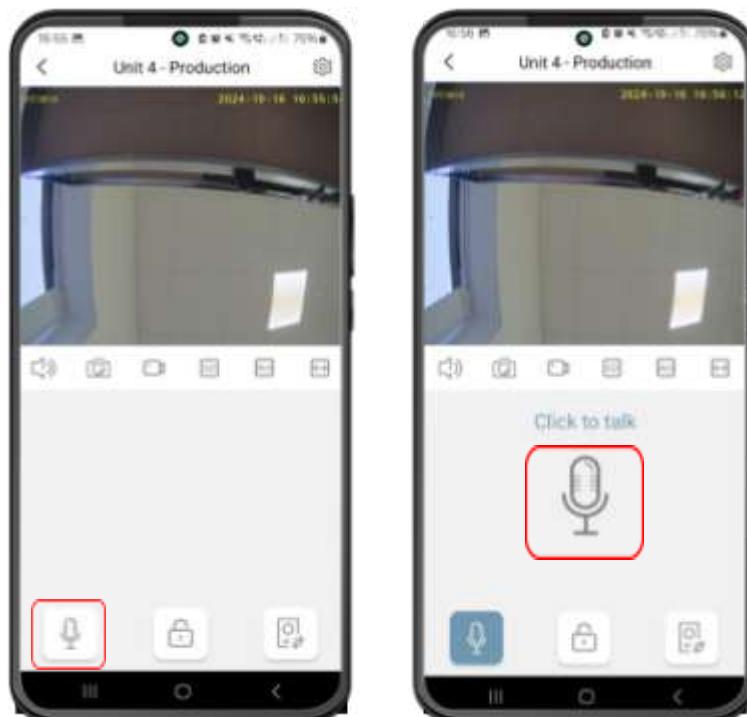

### c. Activate Relays/Locks

To activate the panel relays/locks press the lock icon located at the bottom of the screen. Afterwards two larger lock icons will appear representing each relay/lock. Tapping these will activate the desired relay/lock and at the panel an audible confirmation voice can be heard.

**Note:** The large lock icon will turn blue while active.

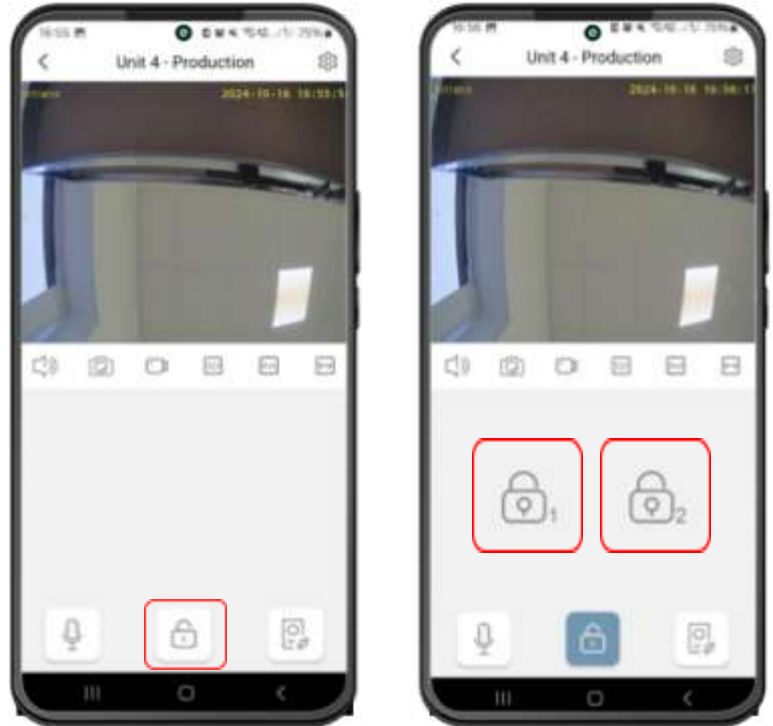

### d. View Cameras

To view additional cameras tap the icon in the bottom right of the screen. This will bring up any IP cameras added to the panel. You can take snapshots and video recordings from these video streams the same as from the panel itself. To add IP cameras see the “Management Portal Operation” section.

**Note:** The camera that is active will be highlighted in blue.

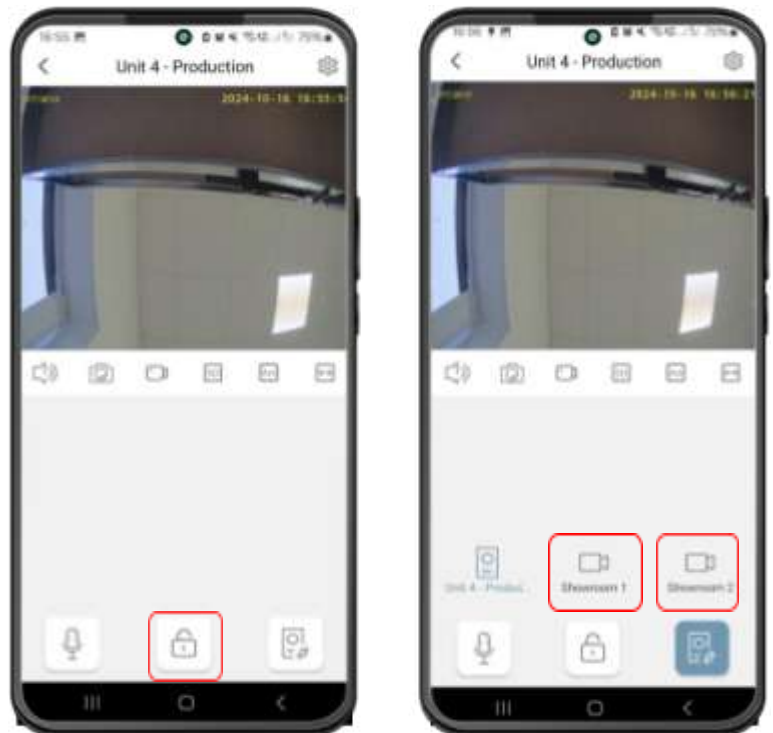

### 3. Devices (Home Page)

The “Devices” page functions as the app’s home page. From here we can access the camera preview, activate relays. Enter different types of settings and more.

#### a. Relay Activation

You can also trigger relays from this screen if you wish. Simply tap the icon for the relay you want to activate and this will momentarily trigger the relay.

#### b. Add Device

You can add a device or scan a site QR using one of the “+” signs located on this page.

#### c. Apartment Settings

Clicking the three dots on this page will open up a menu that can take you to the apartment settings.

#### d. Activity

The activity log can be navigated to by the bottom menu. More info on this feature below.

#### e. Settings

Settings related mainly to the app and calls, more info on this below.

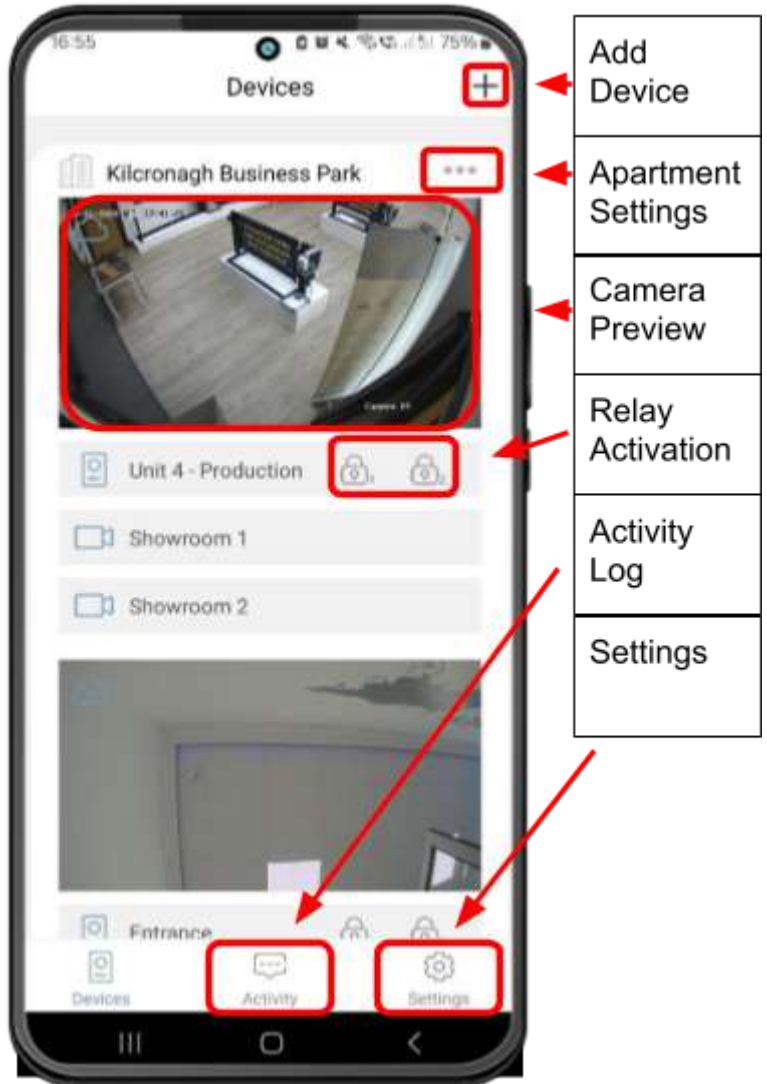

#### f. Camera Preview

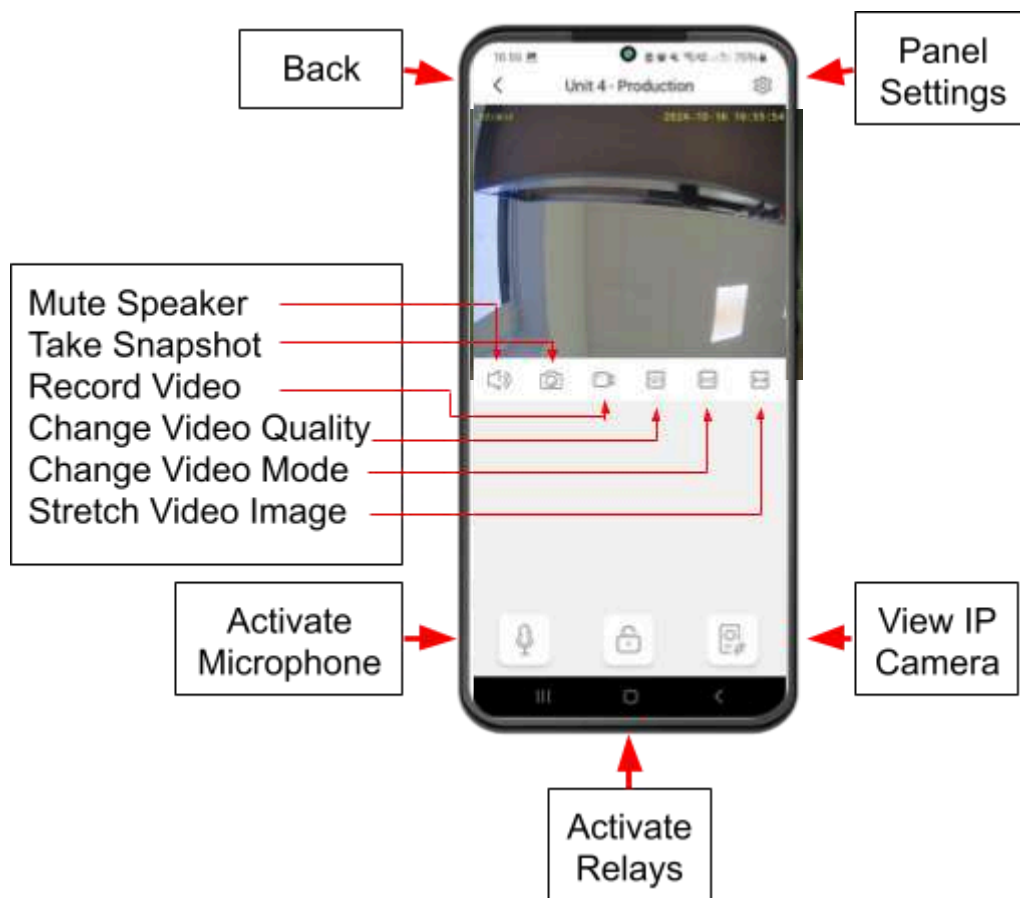

Back - Return to the "Device" page.

Panel Settings - Access the panel specific settings.

Mute Speaker - Disable sound coming from the panel to the phone.

Take Snapshot - Take a picture via the panel's camera.

Record Video - Record a video via the panel's camera.

Change Video Quality - Change between HD, SD or LD for video quality.

Change Video Mode - Change between "Actual" (Real-time stream with potential frame-drops) or "Fluent" (Slightly delayed stream with a fluent picture) video mode.

Stretch Video Image - Use the video stream's actual size or stretch to fill the preview screen.

Activate Microphone - Open two-way speech to answer a call and speak to visitors.

Activate Relay - Operate the system's relays/locks.

View IP Camera - If added to the panel, view IP cameras via the app.

#### 4. Apartment Settings

Within this section of the app you will find settings that affect an apartment and all the panels this apartment has access to.

**a. Apartment Name**

Change the name of your apartment/site as you please.

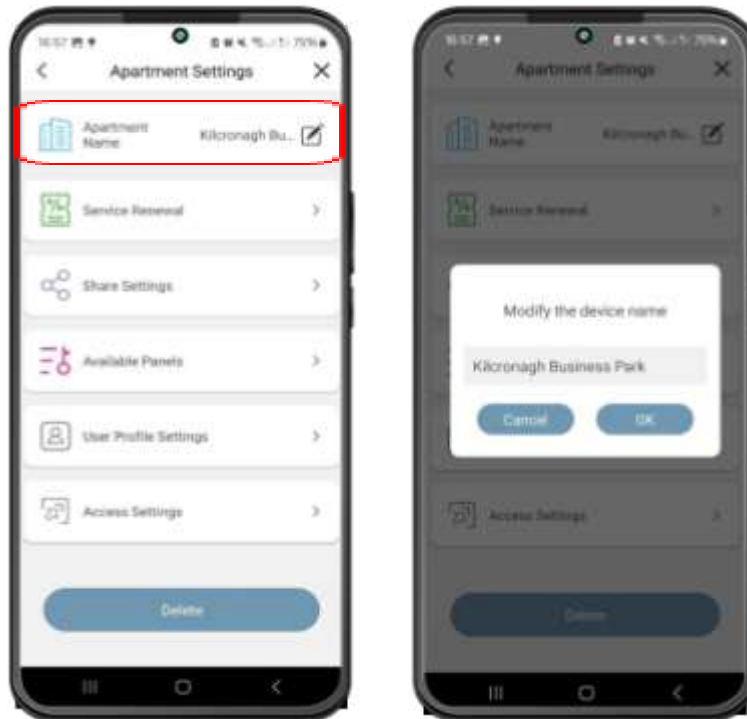

**b. Service Renewal**

Keep track of when the licence for your apartment is going to expire. It is up to management to give you a new one should yours expire.

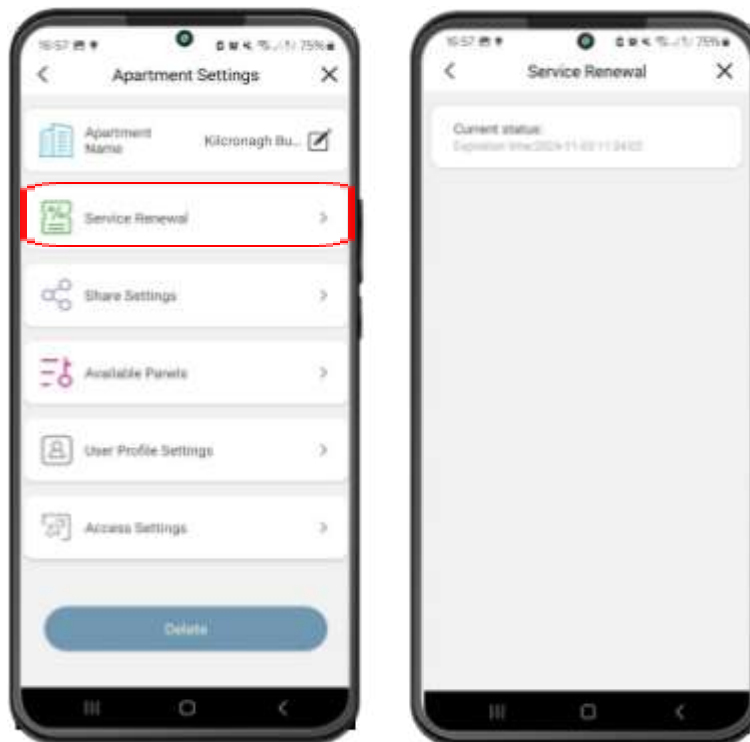

### c. Share Settings

You can easily share access to your apartment. All that is required is that the person you are sharing with has an AES Olyn account and app. You can then search for them using the email they signed up with and send an invite. They will need to accept this on their app and will be given “user” access”.

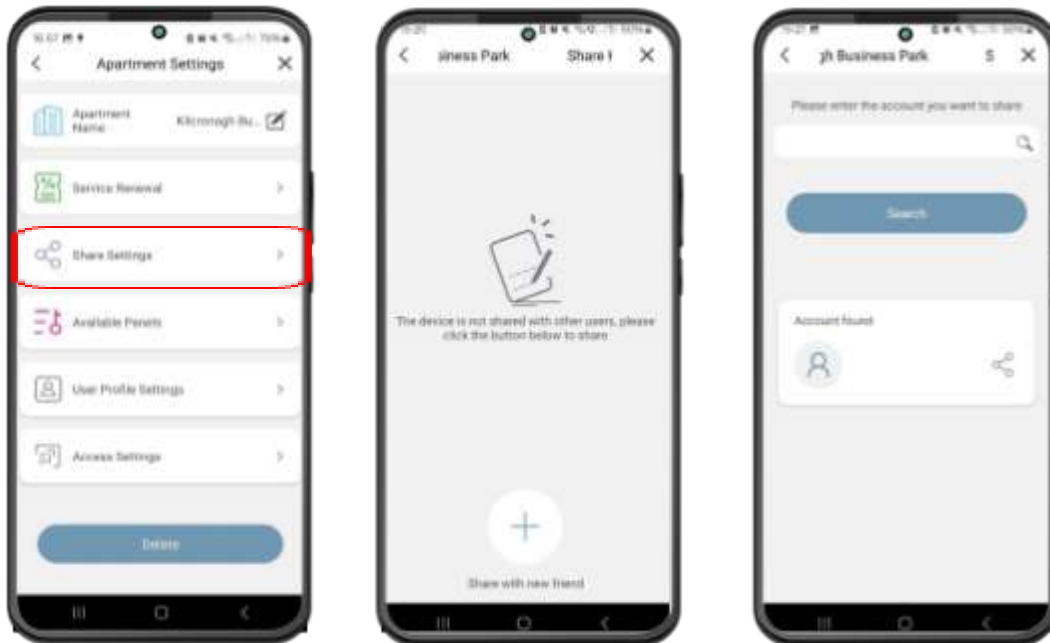

### d. Available Panels

See a list of the panels you have access to. You can choose to enable or disable them being displayed on your “Devices” page.

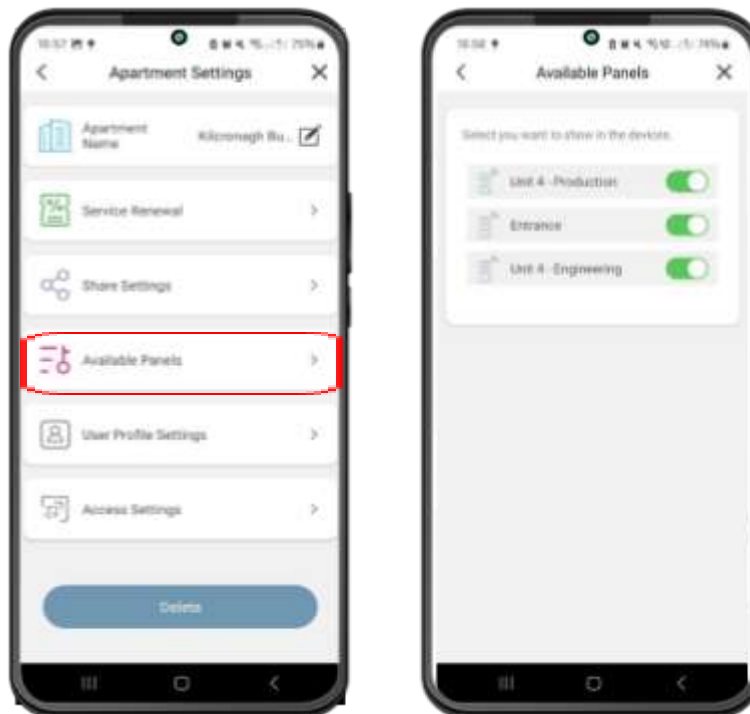

**e. User Profile Settings**

Here you can upload a picture for your user profile. This picture is what will be displayed in the contact list of all panels you have access to. Allowing visitors to easily identify the person they wish to contact.

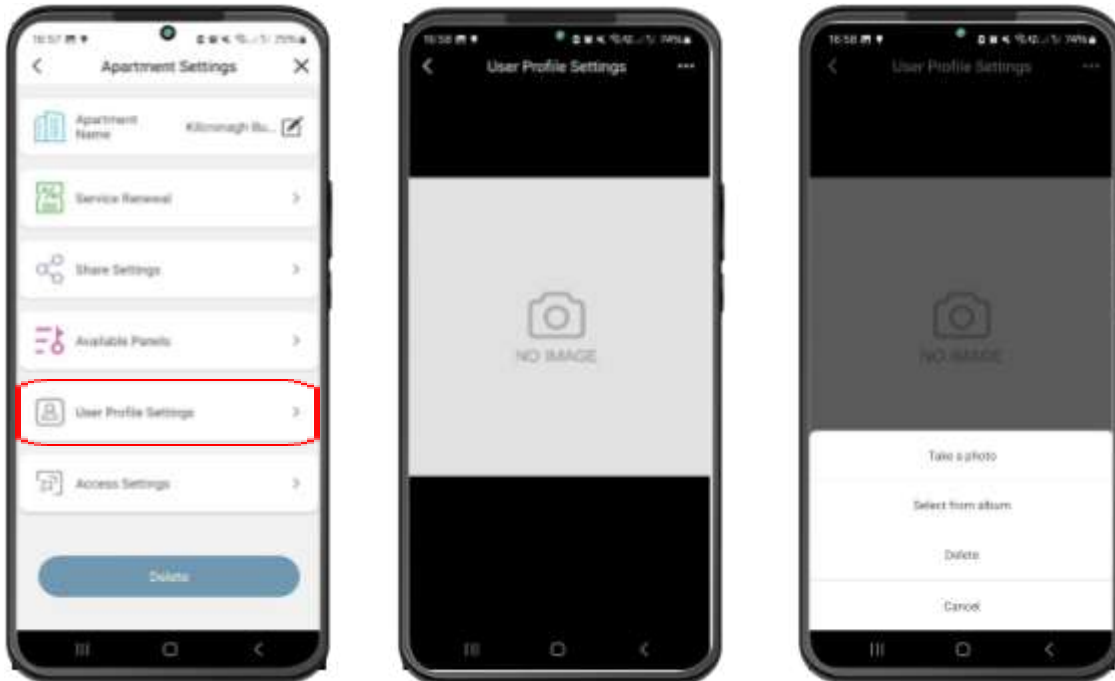

**f. Access Settings**

In this section of the app you can add QR Codes, Keypad Codes and Face ID's to operate the relays/locks of the panel(s).

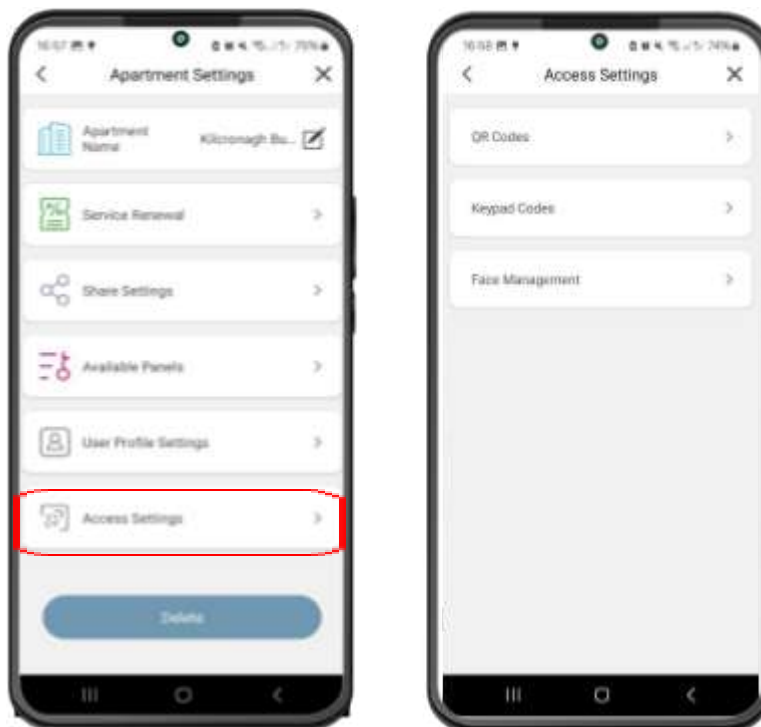

## QR Codes

To add a QR you need to first give it a name. You then need to select the “Lock” you want it to operate followed by the “Number of uses” and “Validity Time”. Both the numbers of users and validity time can be adjusted to suit the needs of the user. They can also be set to “unlimited” and “forever” by pressing the toggles.

Lastly you have the “Panel Sync”. Here you can see all the panels you can add this code to. After you have filled in all the information and selected panel(s) hit “OK”. This will sync the code to all the panels selected.

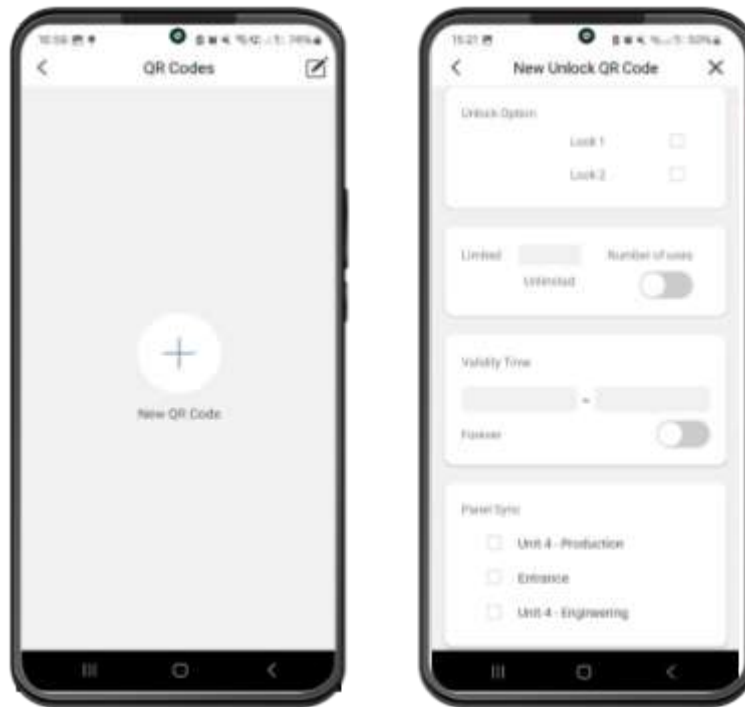

## Keypad Codes

To add a keypad code you need to first give it a name. You then need to input what you want the code to be, followed by selecting the “Lock” you want it to operate followed by the “Number of uses” and “Validity Time”. Both the numbers of users and validity time can be adjusted to suit the needs of the user. They can also be set to “unlimited” and “forever” by pressing the toggles.

Lastly you have the “Panel Sync”. Here you can see all the panels you can add this code to. After you have filled in all the information and selected panel(s) hit “OK”. This will sync the code to all the panels selected.

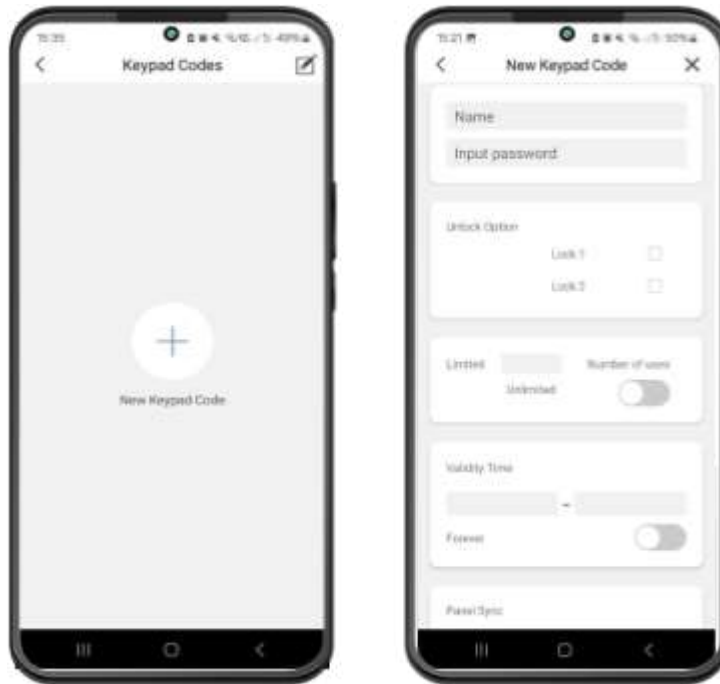

### Face Management

To add a face ID you need to first give it a name. You then need to input what you want the code to be, followed by selecting the “Lock” you want it to operate followed by the “Number of uses” and “Validity Time”. Both the numbers of users and validity time can be adjusted to suit the needs of the user. They can also be set to “unlimited” and “forever” by pressing the toggles.

Lastly you have the “Panel Sync”. Here you can see all the panels you can add this code to. After you have filled in all the information and selected panel(s) hit “OK”. This will sync the code to all the panels selected.

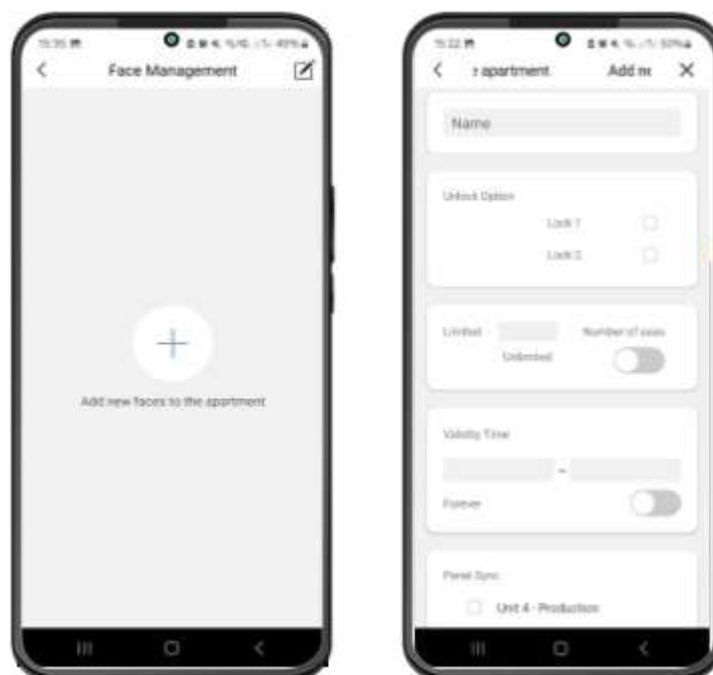

## 5. Panel Settings

Within this section of the app you will find settings that affect the individual panel accessed to reach this section.

### a. Panel Name

Change the name of your apartment/site as you please.

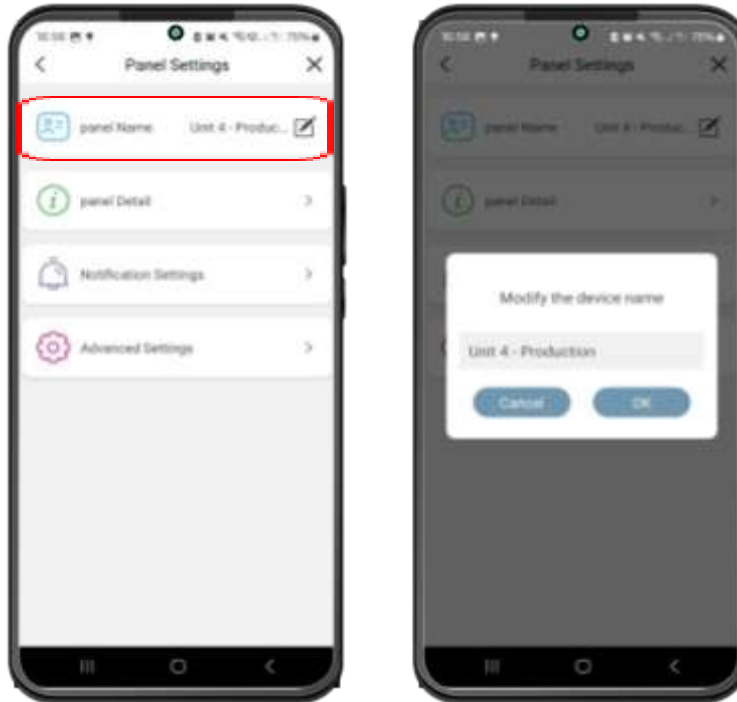

### b. Panel Detail

View details specific to this panel such as its UID, model and software version.

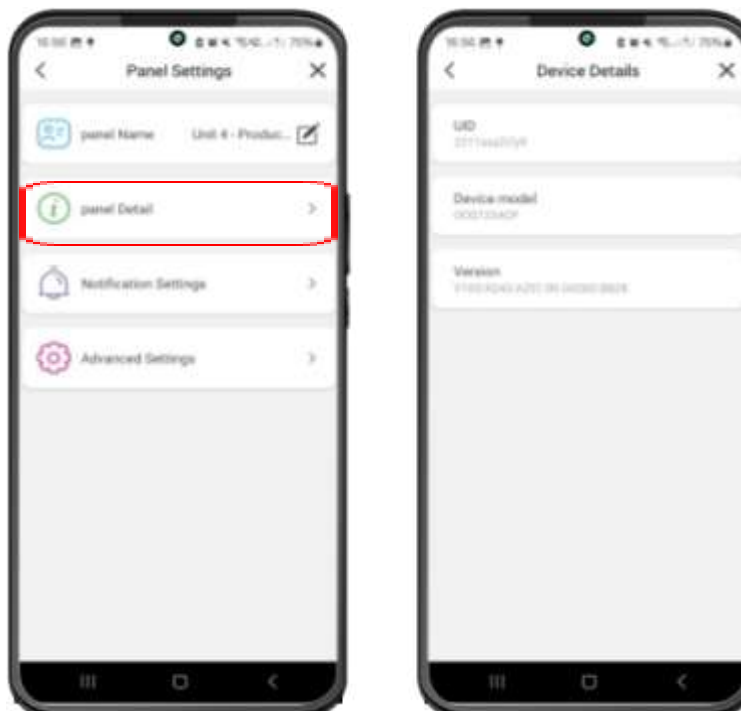

### c. Notification Settings

Enable and disable the different types of notifications you will receive for this panel.

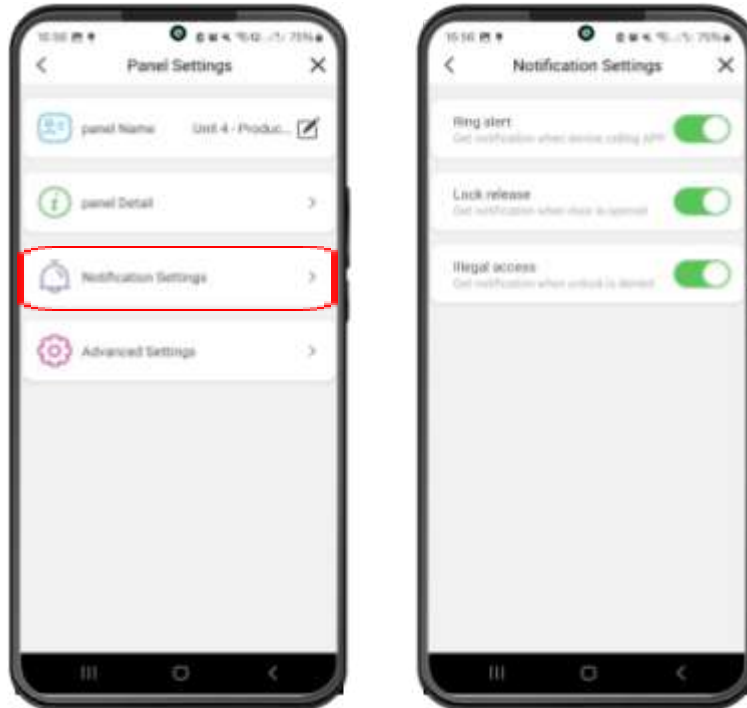

### d. Advanced Settings

This section gives you access to additional features such as creating “Unlock Shortcuts”. Adjusting the “Devices” page shortcuts and changing the “thumbnail” for the panels.

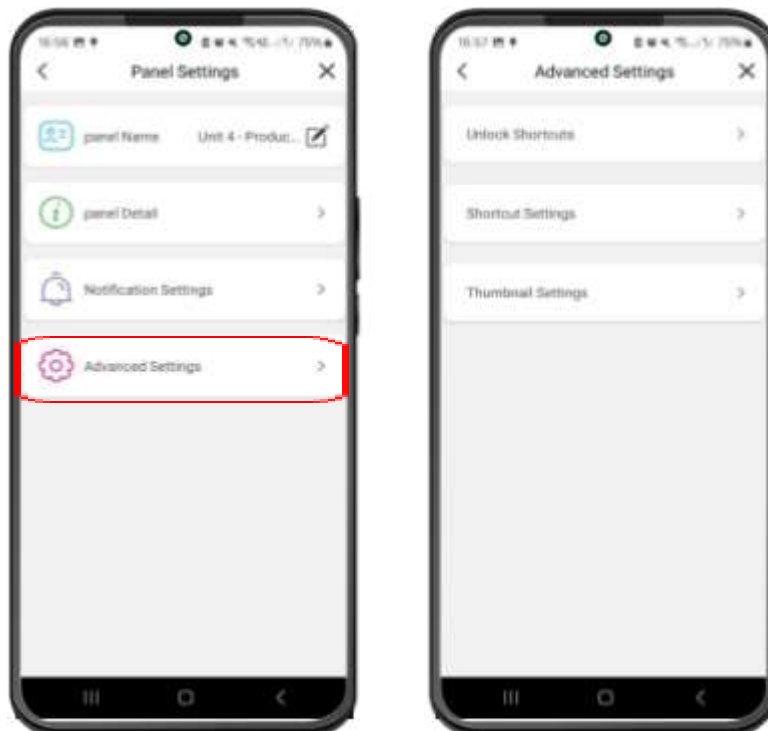

### Unlock Shortcuts

Create a shortcut that will allow quick and easy activation of the panel's relays/locks.

Simply name the shortcut and select the lock you wish to operate then depending on your phone's operating system it will work in 1 of 2 ways.

**Android:** Will create a widget to go on the home screen of your phone. Upon pressing this widget the app will open and automatically activate the chosen lock.

**iOS:** Will create SIRI command that can be used by speaking the phrase "Hey siri, [Shortcut name]". This again will open the app and automatically activate the chosen lock.

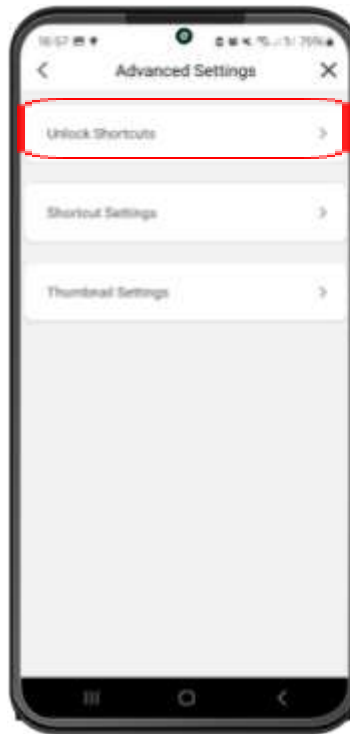

### Shortcut Settings

Here you can enable and disable additional IP cameras to be shown on the "Devices" page. This is only applicable if there are additional IP cameras added to this panel. To add these see the "Management Portal Operation" section.

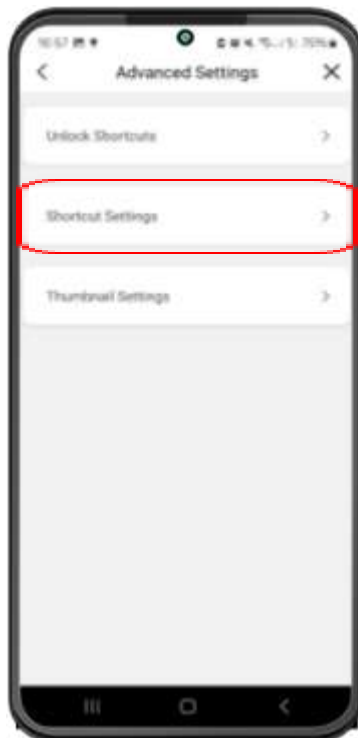

## Thumbnail Settings

Add or delete a thumbnail to be added to the panel. The purpose of a thumbnail is to always be shown on the “Devices” page rather than a snapshot from the last video session.

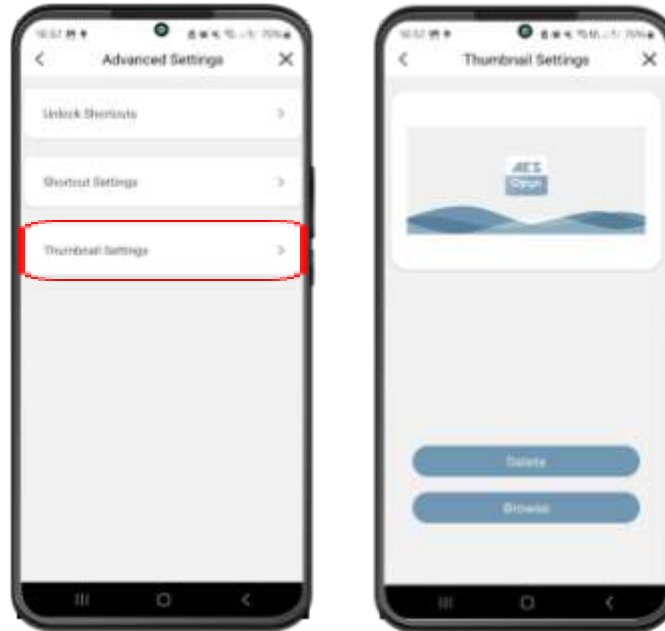

## 6. Activity Log

From this page you can view the events relevant to your apartments. Be that calls made to your apartments or qr codes, keypad and face IDs registered to your apartment. You can view a snapshot of the visitor taken at the moment of the call being initiated by clicking the thumbnail. You can also save this to your app album.

You also have the ability to delete events. You start this process by using the icon in the top right corner. Then you can either delete individual events or select all and delete.

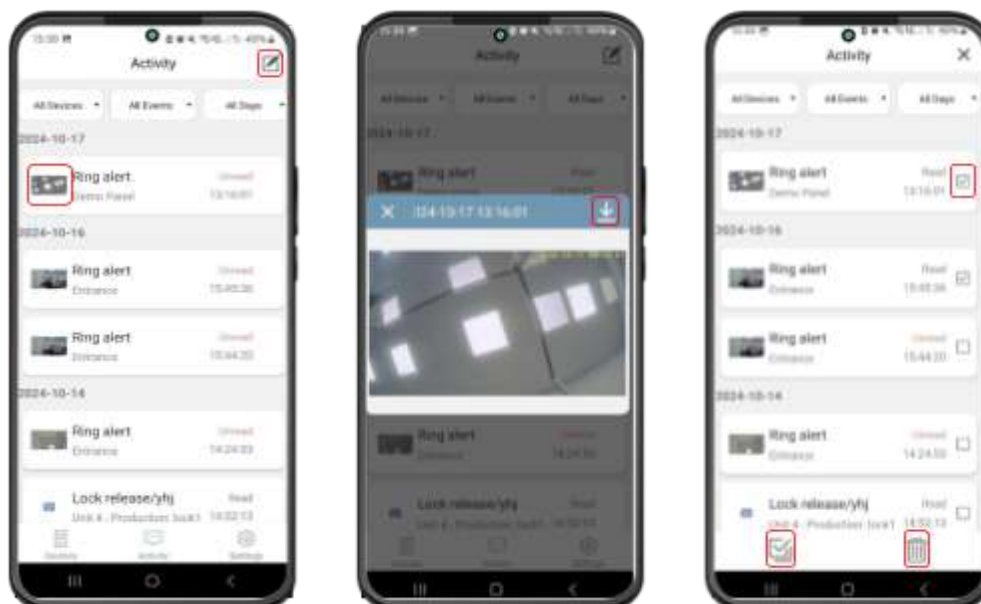

## 7. Settings

In this section of the app you will find general settings regarding your account, app and more.

### a. Account

The accounts page lets you change your “nickname”, delete your account and change the login password. You can also logout from this page.

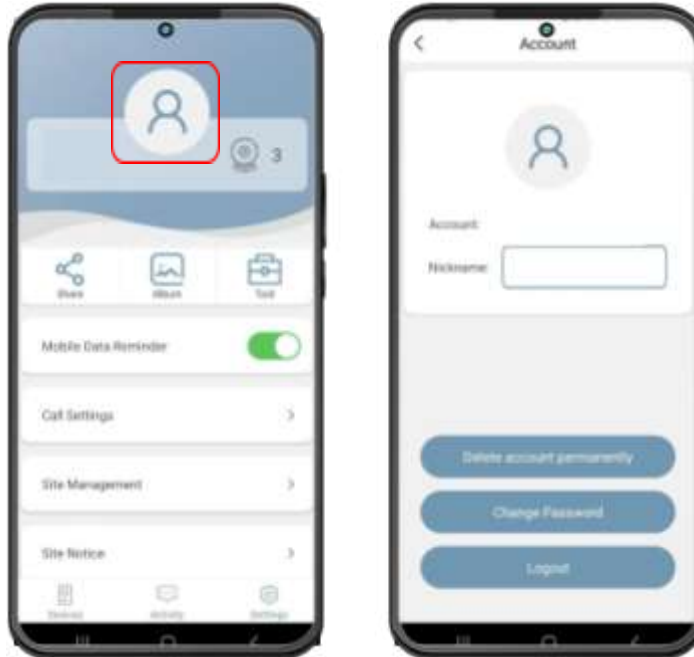

### b. Share

This page will display all the users you are sharing your apartment with, but also show all the apartments that are being shared with you by other users.

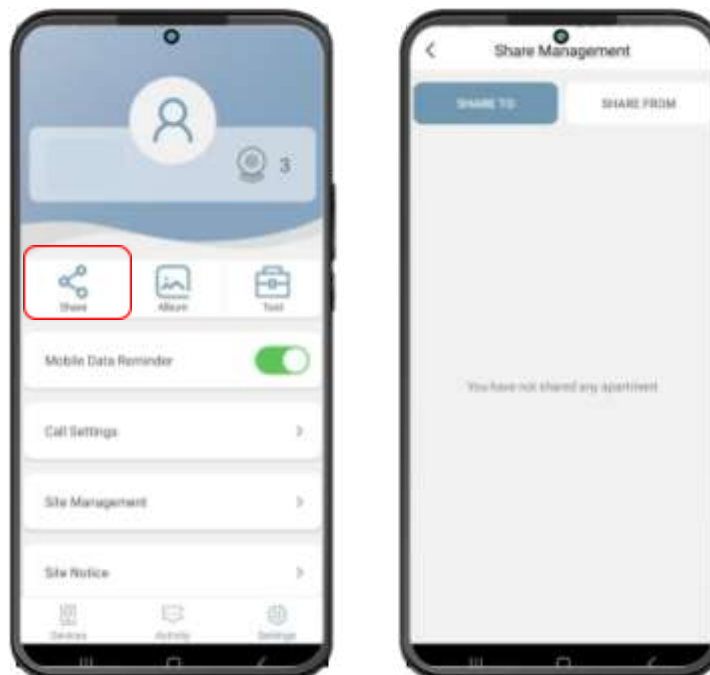

### c. Album

The album will display photos and videos saved either from the activity log or directly from the camera preview page. You can save these directly to your phone from here or delete them. These are saved in the device app memory.

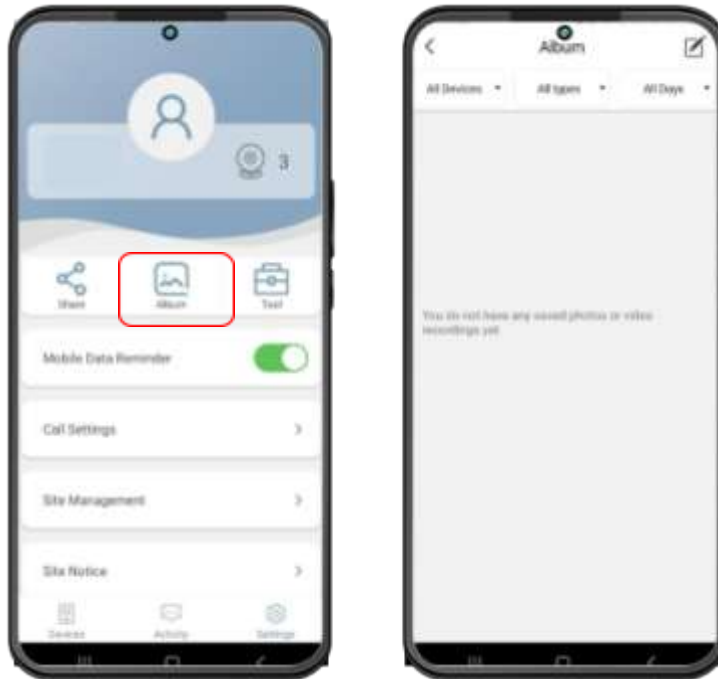

### d. Tool

This section's features do not really affect the "Opyn Multi" system. Instead it is meant to work with the standard AES Opyn single button intercom system.

### e. Mobile Data Reminder

This reminder will appear when your device is using mobile data while viewing the camera. The purpose behind this reminder is to avoid you using up all your mobile data unintentionally.

### f. Call Settings

This page lets you adjust settings specific to the incoming calls. These settings include:

Do not disturb - Which will disable all notifications from the app when enabled.

Notification with picture - Relates to calls, motion, alarm notifications. Enabling this allows you to see a snapshot in the notification banner taken by the camera at the time of the event.

Ringtone Selection - Change the ringtone for incoming calls.

Sound - Enabling or disabling this will determine if incoming calls will have a ringtone or be silent.

Vibration - Enabling or disabling this will determine if incoming calls have vibration or not.

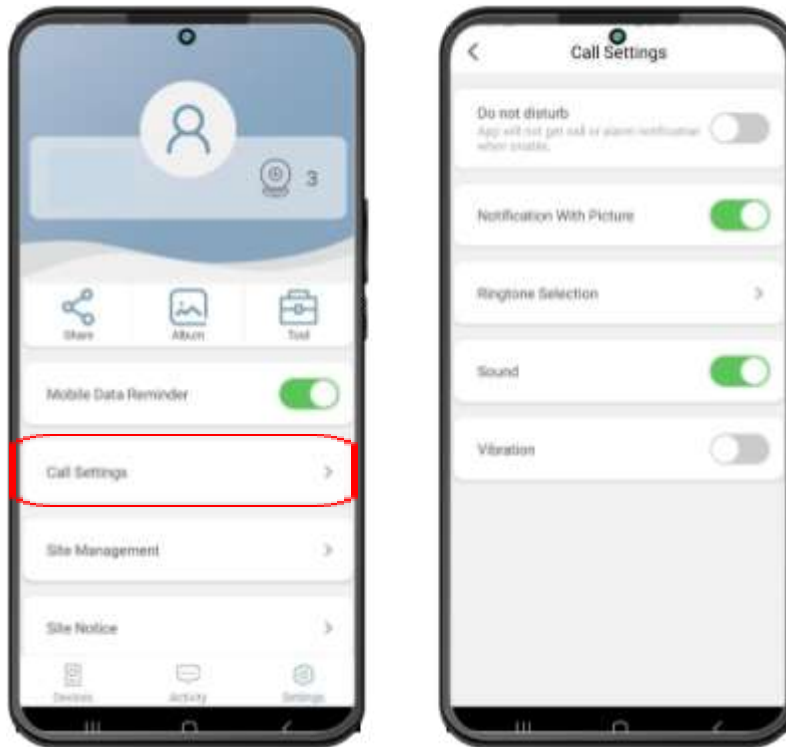

**g. Site Management**

This page lets you see all the apartments you have access to, when your licence will expire for each and how many panels in each apartment gives you access to. Using the “More details” button will take you to “Apartment Settings”.

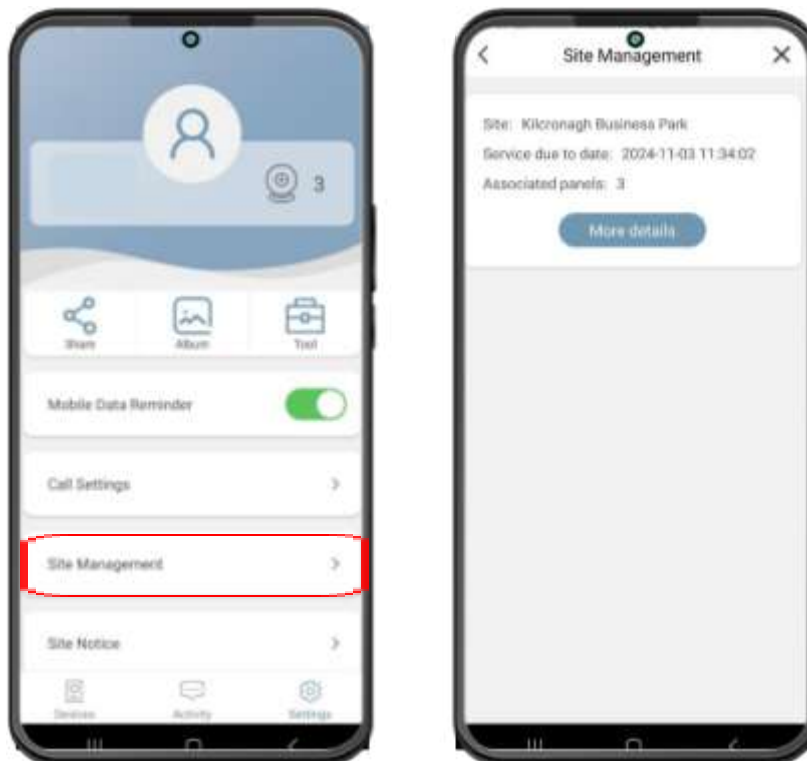

#### h. Site Notice

Management has the ability to send out notices that can be for all users within the site or also specific apartments. If you get a notice it will firstly appear for you as a push notification but can also be viewed in full within the app from this page as long as it has not been removed by management or expired.

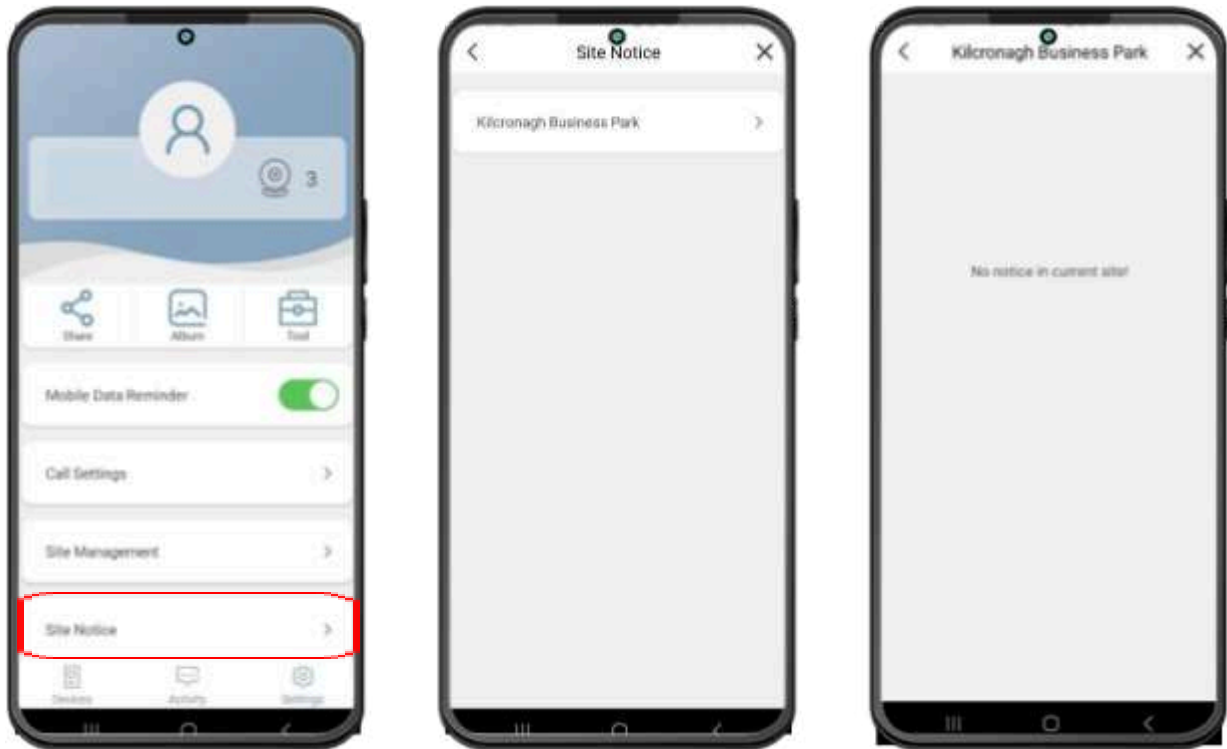

#### i. User Help

We have added a built-in “User Help” section into the app which will answer several frequently asked questions around your account, device setup, playback features and more. We hope that users will find this helpful and prevent them from having to go look for the answer elsewhere.

#### j. About

This page will give you information about the app version and the date it was released along with access to our T&Cs and Privacy Policy.

## Local Web Interface Operation

There are also some additional features that can only be accessed by connecting to the panel via the local-area-network. This means that both the panel and the computer accessing this page need to be on the same network (IP scheme). We will only cover the essential features here and do not recommend adjusting any settings not covered in this manual.

To access this page you will need to enter the IP address of your panel into your browser. The IP can be found via the panel itself in the “Device Information” page that can be accessed from “Settings”.

The default login credentials are:

*Username: admin*

*Password: 888999*

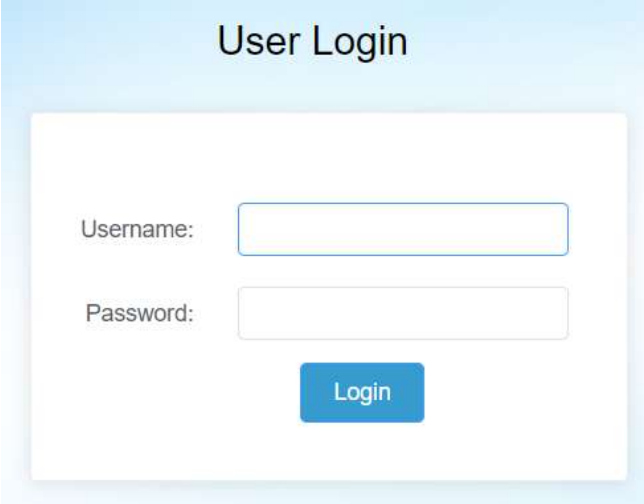

The image shows a 'User Login' form with a light blue header. Below the header, there are two input fields: 'Username:' and 'Password:'. A blue 'Login' button is positioned below the password field.

## Local Config

The features on this page include:

- View device IP & MAC address
- Enable or disable tamper alarm
- Adjust unlock time for lock 1 or lock 2
- Change default state of exit button

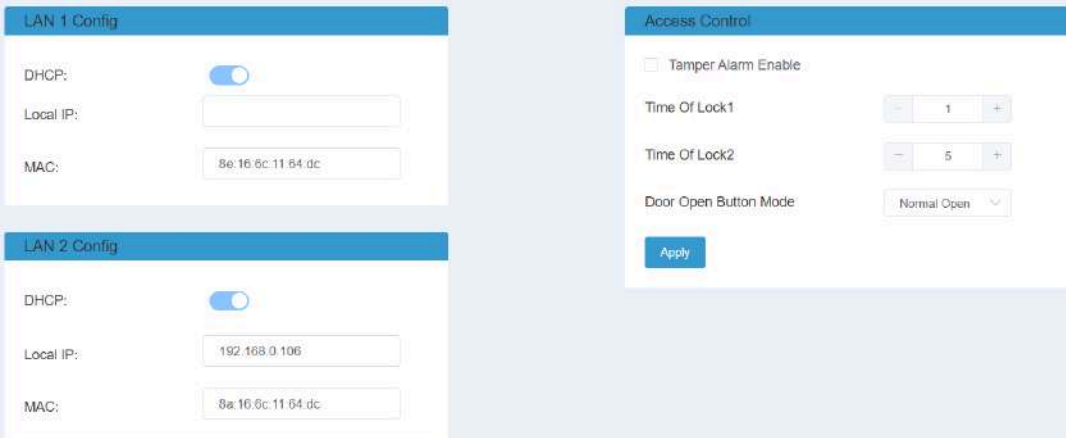

The image displays the 'Local Config' interface, which is split into two main sections. The left section contains 'LAN 1 Config' and 'LAN 2 Config'. Each section has a 'DHCP:' toggle switch (currently on), a 'Local IP:' text input field, and a 'MAC:' text input field. The right section is titled 'Access Control' and includes a 'Tamper Alarm Enable' checkbox (unchecked), 'Time Of Lock1' and 'Time Of Lock2' numeric input fields with minus and plus buttons (values 1 and 5 respectively), and a 'Door Open Button Mode' dropdown menu (set to 'Normal Open'). An 'Apply' button is located at the bottom of the 'Access Control' section.

## Rtsp Config

Enable RTSP streaming of the Opyn Multi. Make sure you click “Enable” then enter a desired password and username followed by “Apply”. You can now start using the RTSP stream.

### Rtsp

Enable

User:  4/24

PassWord:  8/24

## Dtmf Config

Same functionality as on the cloud portal. Lets you adjust the keys needed to be pressed on a SIP device to trigger lock 1 or lock 2 and in some cases to open 2-way speech.

### Dtmf

unlock 1:

unlock 2:

monitor talk:

## Screensavers

Here you can add or delete screensaver images to the system. The system can take up to 3 screensaver images rotating roughly every 30 seconds. The “reset” button will bring back the default AES screensaver should it be needed.

We recommend uploading pictures with a 9:16 ratio and 600 x 1024 pixels.

**Note:** The screensaver will start after approximately 200s of the screen not being touched, or having detected a face depending on the setting chosen in the panel.

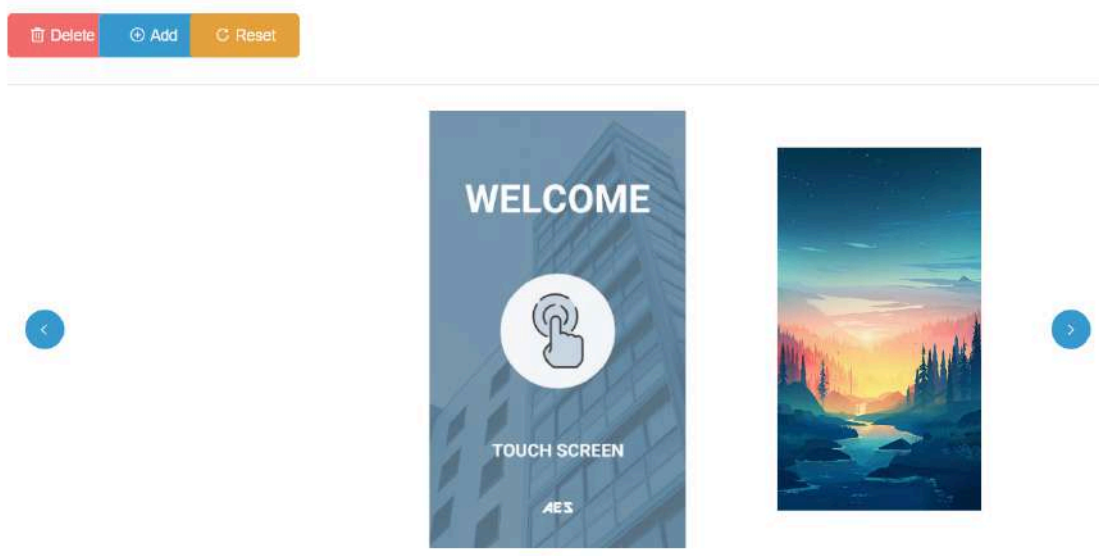

## User Management

This allows you to change the default login details for this page.

UserName	Remarks	Operation
admin		<a href="#">Edit</a>

## Maintenance

Here we can see panel information such as its software version, hardware version and ID. We can also update the firmware or reboot the device from here.

Software Version:	Aug 28 2024 14:37:31
Hardware Version:	ver.c
Cloud Uid:	2211xsqcymyr
Cloud Outer Auth Code:	DCDPXNCX

[Update](#) [Reboot Device](#) [View Log](#)

## App Updates

We will continually monitor the app's performance and release updates to enhance the user's experience and/or fix any issues that arise over time. These updates will be available via the iOS App Store or the Google Play Store.

## Firmware Updates

Firmware updates will be released to fix any bugs or to add additional features where possible throughout the product's lifetime. The firmware version your system is using can be seen via the app.

## Warranty

Please note, by installing this product, you are accepting our warranty terms. This warranty is a "return to base" 2-year manufacturer's warranty.

For full warranty terms and conditions contact the AES Technical Support Team